

DATE	EC NO.	PART NO.	
06/12/03	J18444	93P4047	
		DEVELOPMENT NO.	Q/M
			1 /83

TOKYO-3 PLANAR SVT

VER 2.00 JUN/12/2003

<http://bufanxiu.taobao.com>

- | | |
|--|---|
| <ul style="list-style-type: none"> 1. TITLE PAGE 2. EC HISTORY 3. CONFIG MATRIX 4. CPU:BANIAS (1/3) 5. CPU:BANIAS (2/3) 6. CPU:BANIAS (3/3) 7. CPU:ITP 8. CPU:DECAP (VCCCPUCORE) 9. NORTH:ODEM(1/4) 10. NORTH:ODEM(2/4) 11. NORTH:ODEM(3/4) 12. NORTH:ODEM(4/4) 13. MEMORY:DUAL DDR DIMM 14. MEMORY:TERMINATION 15. MEMORY:DECOUPLING 16. MEMORY:RESERVE 17. CLOCK GENERATOR:CK-408 18. GFX:RAGE M9(1/6) 19. GFX:RAGE M9(2/6) 20. GFX:RAGE M9(3/6) 21. GFX:RAGE M9(4/6) 22. GFX:RAGE M9(5/6) 23. GFX:RAGE M9(6/6) 24. GFX:CLK MODULATOR 25. GFX:EXT CRT CONNECTOR 26. GFX:LCD CONNECTOR 27. GFX:RESERVE 28. SOUTH:ICH4(1/3) 29. SOUTH:ICH4(2/3) 30. SOUTH:ICH4(3/3) 31. CARDBUS:R5C554(1/2) 32. CARDBUS:R5C554(2/2) 33. CARDBUS:POWER CONTROL 34. CARDBUS:PCMCIA SLOT 35. CARDBUS:COMPACT FLASH 36. ETHERNET:GIGABIT(1/2) 37. ETHERNET:GIGABIT(2/2) 38. ETHERNET:MAGNETICS 39. ETHERNET:RJ11/45 CONN 40. MINIPCI CONNECTOR | <ul style="list-style-type: none"> 41. CDC CONNECTOR(BMDC) 42. PCI BUS SWITCH(1/2) 43. PCI BUS SWITCH(2/2) 44. DOCKING CONNECTOR 45. AUDIO:AD1981B 46. AUDIO:INT MIC 47. AUDIO:HP/LINE-IN CONN 48. AUDIO:EXT MIC 49. AUDIO MISC(1/2) 50. AUDIO MISC(2/2) 51. AUDIO:BA7787 52. LPC:FWH&RTC BATTERY 53. LPC:H8S/2169A 54. LPC:MISC GA(PMH-4) 55. LPC:PC87392 56. HDD CONNECTOR 57. USB CONNECTOR 58. USB POWER 59. KEYBOARD 60. SERIAL DRIVER 61. PARALLEL CONNECTOR 62. SUBCARD CONNECTOR 63. FAN CONNECTOR AND LED / GND PTH 64. INTENTIONAL BLANK 65. POWER ON LOGIC 66. SLICE SUPPORT 67. THERMAL SENSOR 68. I2CBUS/SMBUS 69. DCDC:DC-IN AND CHARGER 70. DCDC:CHARGER SELECT 71. DCDC:BATTERY INPUT 72. DCDC:BATTERY MONITOR 73. DCDC:POWER SEQUENCE 74. DCDC:VCC3M/5M 75. DCDC:VCCCPUCORE 76. DCDC:VCC1R2M & VCCCPUIO 77. DCDC:VCC2R5A & VCC1R25B 78. DCDC:VCC1R8M & VCCVIDEOCORE 79. DCDC:VCC1R5M/A/B/AUX 80. DCDC:TSURUMAI 81. DCDC:VCC FOR GIGABIT ETHER 82. DCDC:LOAD SW 83. DCDC:MAX POWER CONTROL |
|--|---|

DRAWING:

93P4047

DESIGNER	Y.Y	06/12/03	PART NO.	93P4047	
CHECKED	Y.I	06/12/03			
APPROVED	K.T	06/12/03	TITLE TOKYO-3 SVT(2.00)		
CLASS			TITLE PAGE		
<small>THIS DOCUMENT IS THE PROPERTY OF IBM ITS USE IS AUTHORIZED ONLY FOR RESPONDING TO A REQUEST FOR QUOTATION OR FOR THE PERFORMANCE OF WORK FOR IBM. ALL QUESTIONS MUST BE REFERRED TO THE IBM PURCHASING DEPARTMENT.</small>					IBM CONFIDENTIAL

	DATE	EC NO.	PART NO.
	06/12/03	J18444	93P4047
			DEVELOPMENT NO.
			Q/M
			2 /83

TOKYO-2

DV

0.01 FEB/21/2002 INITIAL
0.02 FEB/27/2002 APPLY EC-017-023
0.07 MAR/19/2002 APPLY EC-041-049
0.08 MAR/25/2002 APPLY EC-050-059
0.09 MAR/29/2002 APPLY EC-60-069
0.10 APR/01/2002 APPLY EC-70-079
0.11 APR/01/2002 APPLY EC-80-083
0.12 APR/03/2002 APPLY EC-84-091
0.13 APR/09/2002 APPLY EC-92-096
0.14 APR/12/2002 APPLY EC-97-103
0.15 APR/19/2002 APPLY EC-104-113
0.16 APR/25/2002 APPLY EC-114-121
0.17 MAY/08/2002 APPLY EC-122-133
0.18 MAY/10/2002 APPLY EC-134-138
0.19 MAY/14/2002 APPLY EC-139-146
0.20 MAY/15/2002 APPLY EC-147-149
0.21 MAY/17/2002 APPLY EC-150
0.22 MAY/20/2002 ADD PTH HOLE FOR GND PAD
MAY/27/2002 APPLY EC-151-153

SIV

1.00 JUN/24/2002 APPLY EC154,155,EC201-212
1.01 JUN/27/2002 APPLY EC215-217
1.02 JUN/27/2002 APPLY EC218
1.03 JUL/09/2002 APPLY EC220-232
1.04 JUL/15/2002 APPLY EC233-246
1.05 JUL/16/2002 APPLY EC247-250
1.06 JUL/17/2002 APPLY EC251-256
1.07 JUL/18/2002 APPLY EC257-261
1.08 JUL/19/2002 APPLY EC262-266
1.09 JUL/24/2002 APPLY EC267-271
1.10 JUL/30/2002 APPLY EC272-275
1.11 AUG/02/2002 APPLY EC276-278
1.12 AUG/06/2002 APPLY EC279-280
1.13 AUG/14/2002 APPLY EC281

SIT

2.00 SEP/10/2002 APPLY EC279,
SIV REWORK001,002,EC300-EC321
2.01 SEP/12/2002 APPLY EC322-EC330
2.02 SEP/13/2002 APPLY EC331-EC334
2.03 SEP/17/2002 APPLY EC335-EC345
2.04 SEP/19/2002 APPLY EC346-EC354
2.05 SEP/20/2002 APPLY EC355-EC357
2.06 SEP/24/2002 APPLY EC359

2.07 SEP/26/2002 APPLY EC360,362,364-366
2.08 SEP/30/2002 APPLY EC367-369
2.09 OCT/02/2002 APPLY EC370-376
2.10 OCT/07/2002 APPLY EC377-379
2.11 OCT/08/2002 APPLY EC380
2.12 OCT/09/2002 APPLY EC385-387

SIT-3

2.13 OCT/23/2002 APPLY EC390-391,CHANGE CAP HEIGHT(29L0929->26P1806)
2.14 OCT/28/2002 APPLY EC393-395

SIT-4

3.00 OCT/28/2002 APPLY REWORK EC-SIT001-EC400-413
3.01 OCT/29/2002 APPLY EC-414,416
3.02 OCT/29/2002 APPLY EC-418
3.03 NOV/13/2002 APPLY EC-421-425

SVT

4.00 DEC/17/2002 APPLY EC-500,502,504
4.01 DEC/24/2002 APPLY EC-506
4.02 JAN/07/2003 APPLY TK2-AEC-002

TOKYO-3

SDV

0.01 FEB/24/2003 INITIAL APPLY EC-001,002
0.02 MAR/07/2003 APPLY EC-009
0.03 MAR/13/2003 APPLY EC-011

SIT

1.00 APR/09/2003 INITIAL APPLY EC-100-104
1.01 APR/15/2003 APPLY EC-106(ADD DIODE)
1.02 MAY/09/2003 APPLY EC-112(CHANGE PLANAR ID)

SVT

2.00 JUN/12/2003 APPLY EC201

93P4047

DESIGNER	Y.Y	06/12/03	PART NO.	IBM
CHECKED	Y.I	06/12/03	93P4047	
APPROVED	K.T	06/12/03	TITLE TOKYO-3 SVT(2.00)	
CLASS			EC HISTORY	
THIS DOCUMENT IS THE PROPERTY OF IBM ITS USE IS AUTHORIZED ONLY FOR RESPONDING TO A REQUEST FOR QUOTATION OR FOR THE PERFORMANCE OF WORK FOR IBM. ALL QUESTIONS MUST BE REFERRED TO THE IBM PURCHASING DEPARTMENT.				IBM CONFIDENTIAL

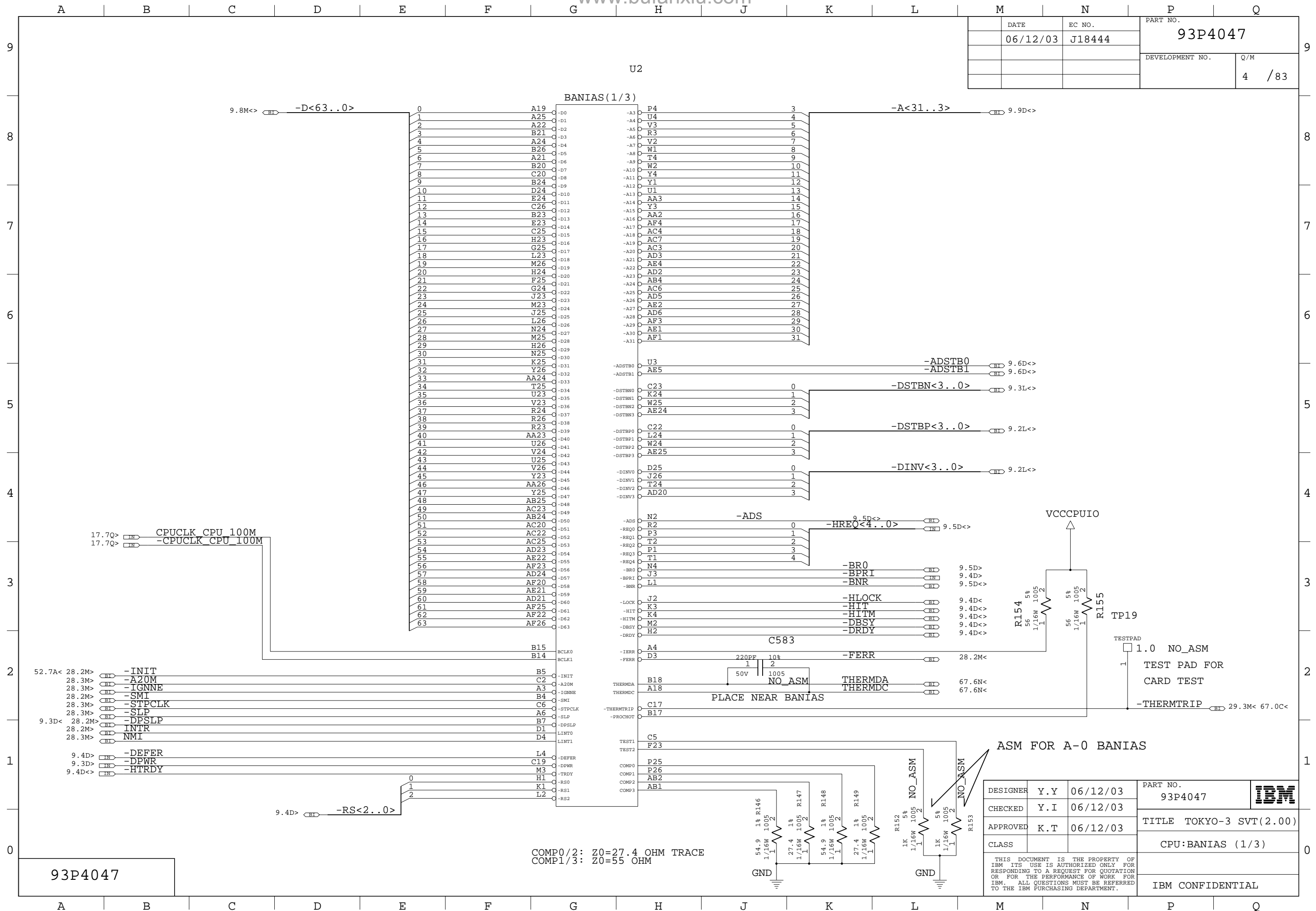

DATE	EC NO.	PART NO.	
06/12/03	J18444	93P4047	
		DEVELOPMENT NO.	Q/M
		4	/83

DESIGNER	Y.Y	06/12/03	PART NO.	93P4047	IBM
CHECKED	Y.I	06/12/03	TITLE TOKYO-3 SVT(2.00)		
APPROVED	K.T	06/12/03	CPU: BANIAS (1/3)		
CLASS			IBM CONFIDENTIAL		

THIS DOCUMENT IS THE PROPERTY OF IBM ITS USE IS AUTHORIZED ONLY FOR RESPONDING TO A REQUEST FOR QUOTATION OR FOR THE PERFORMANCE OF WORK FOR IBM. ALL QUESTIONS MUST BE REFERRED TO THE IBM PURCHASING DEPARTMENT.

93P4047

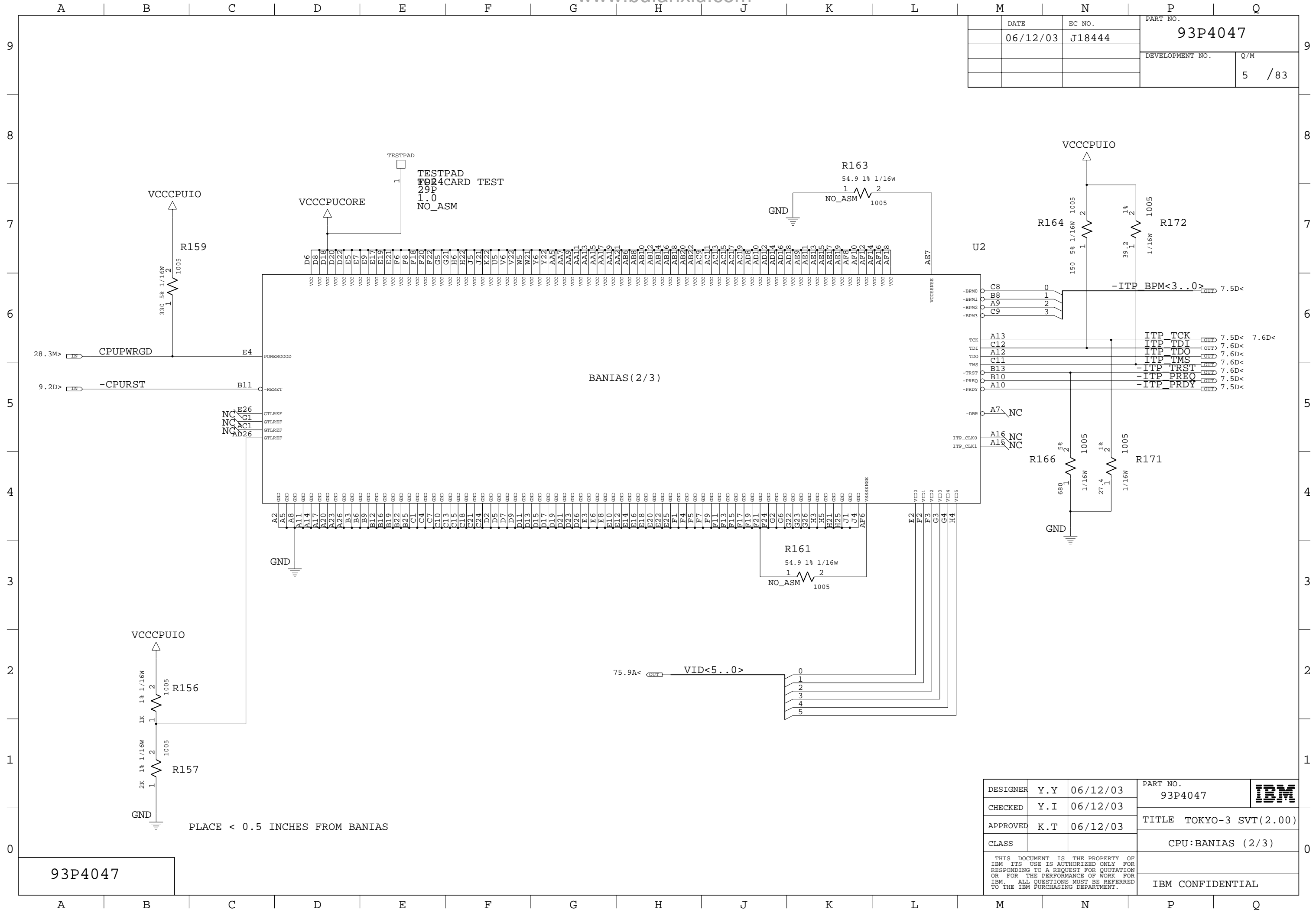

DATE	EC NO.	PART NO.	
06/12/03	J18444	93P4047	
		DEVELOPMENT NO.	Q/M
		5	/83

DESIGNER	Y.Y	06/12/03	PART NO.	93P4047	
CHECKED	Y.I	06/12/03			
APPROVED	K.T	06/12/03	TITLE TOKYO-3 SVT(2.00)		
CLASS			CPU:BANIAS (2/3)		
THIS DOCUMENT IS THE PROPERTY OF IBM ITS USE IS AUTHORIZED ONLY FOR RESPONDING TO A REQUEST FOR QUOTATION OR FOR THE PERFORMANCE OF WORK FOR IBM. ALL QUESTIONS MUST BE REFERRED TO THE IBM PURCHASING DEPARTMENT.					IBM CONFIDENTIAL

93P4047

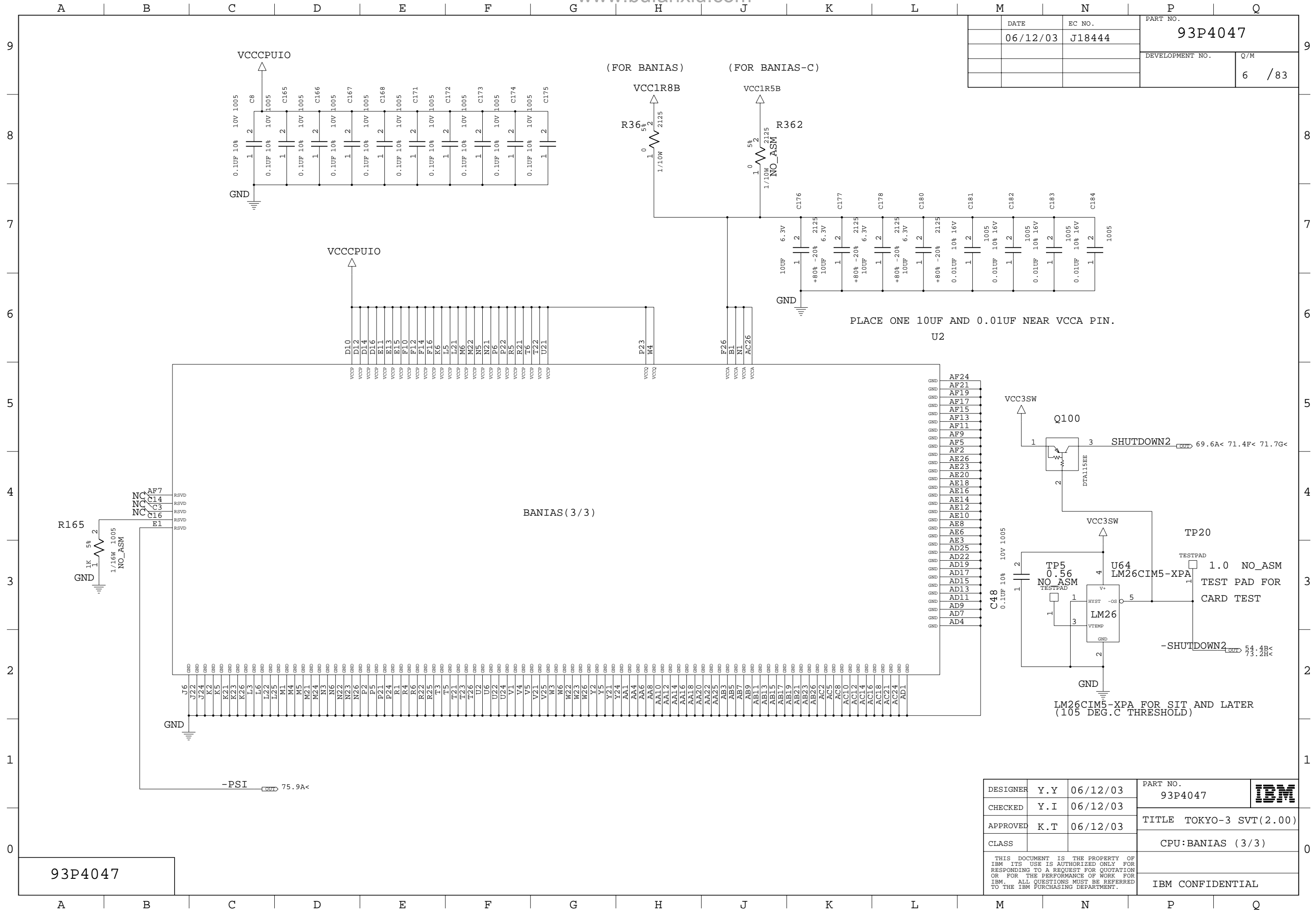

DATE	EC NO.	PART NO.	
06/12/03	J18444	93P4047	
		DEVELOPMENT NO.	Q/M
			6 / 83

PLACE ONE 10UF AND 0.01UF NEAR VCCA PIN.

LM26CIM5-XPA FOR SIT AND LATER (105 DEG.C THRESHOLD)

DESIGNER	Y.Y	06/12/03	PART NO.	93P4047	
CHECKED	Y.I	06/12/03	TITLE TOKYO-3 SVT(2.00)		
APPROVED	K.T	06/12/03	CPU:BANIAS (3/3)		
CLASS			IBM CONFIDENTIAL		

THIS DOCUMENT IS THE PROPERTY OF IBM ITS USE IS AUTHORIZED ONLY FOR RESPONDING TO A REQUEST FOR QUOTATION OR FOR THE PERFORMANCE OF WORK FOR IBM. ALL QUESTIONS MUST BE REFERRED TO THE IBM PURCHASING DEPARTMENT.

93P4047

DATE		EC NO.		PART NO.	
06/12/03		J18444		93P4047	
DEVELOPMENT NO.				Q/M	
				7 / 83	

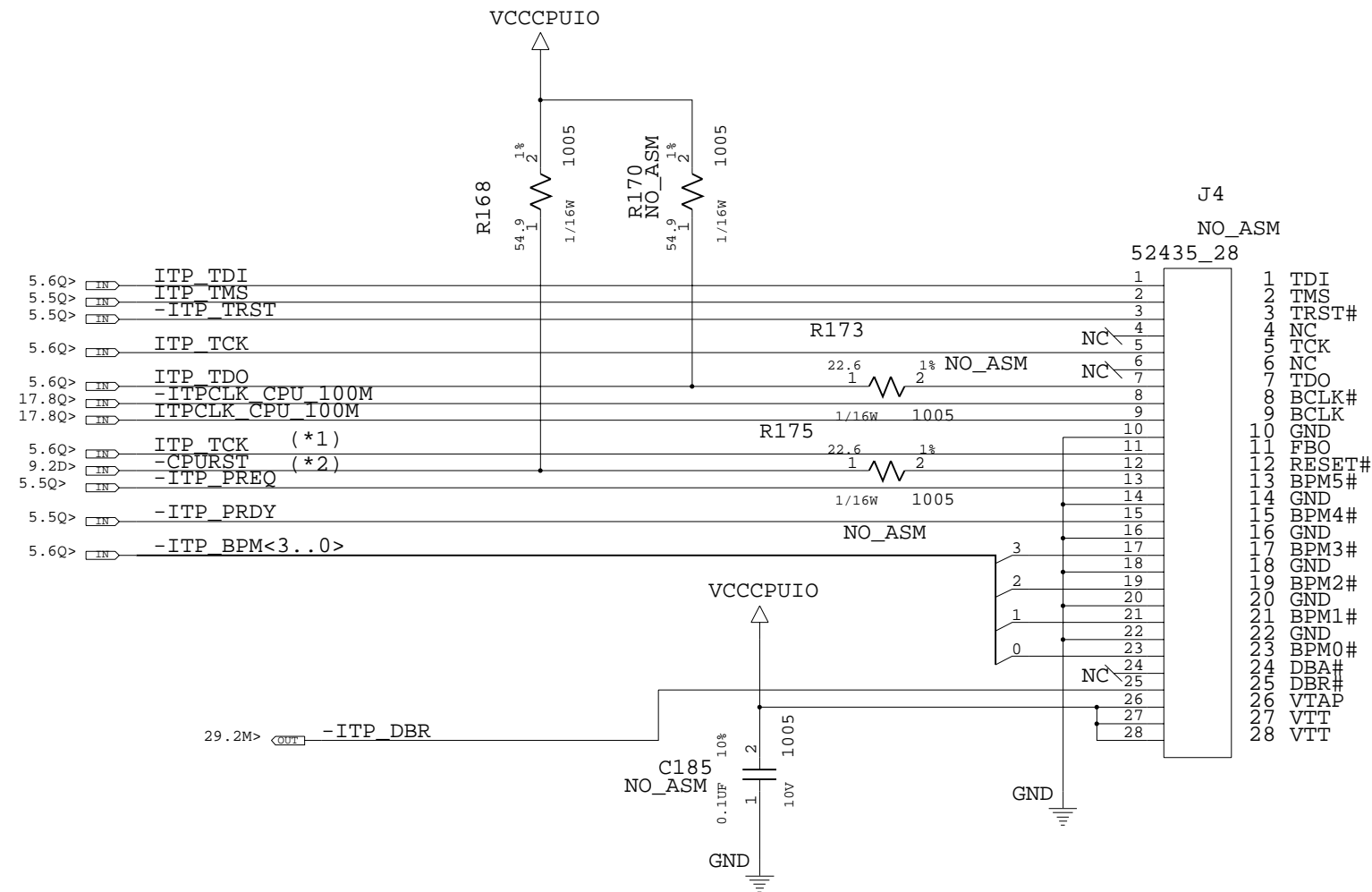

(*1) TCK SIGNAL IS BRANCHED AT BANIAS PIN

(*2) -CPURST SIGNAL IS BRANCHED AT ODEM PIN

93P4047

DESIGNER	Y.Y	06/12/03	PART NO.	93P4047	
CHECKED	Y.I	06/12/03	TITLE TOKYO-3 SVT(2.00)		
APPROVED	K.T	06/12/03	CLASS		CPU:ITP
THIS DOCUMENT IS THE PROPERTY OF IBM ITS USE IS AUTHORIZED ONLY FOR RESPONDING TO A REQUEST FOR QUOTATION OR FOR THE PERFORMANCE OF WORK FOR IBM. ALL QUESTIONS MUST BE REFERRED TO THE IBM PURCHASING DEPARTMENT.					IBM CONFIDENTIAL

	DATE	EC NO.	PART NO.	
	06/12/03	J18444	93P4047	
			DEVELOPMENT NO.	Q/M
			8	/83

TO CONFIRM ACTUAL CAP

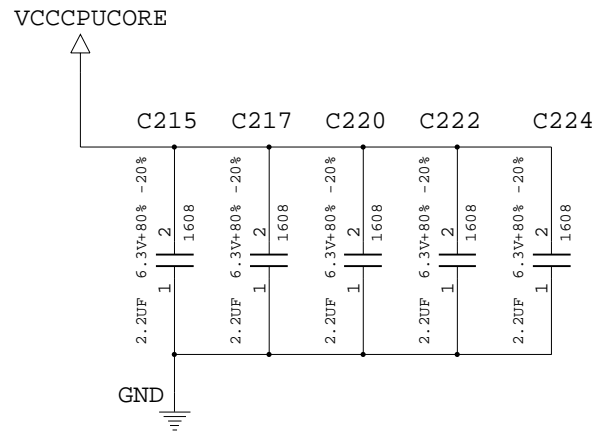
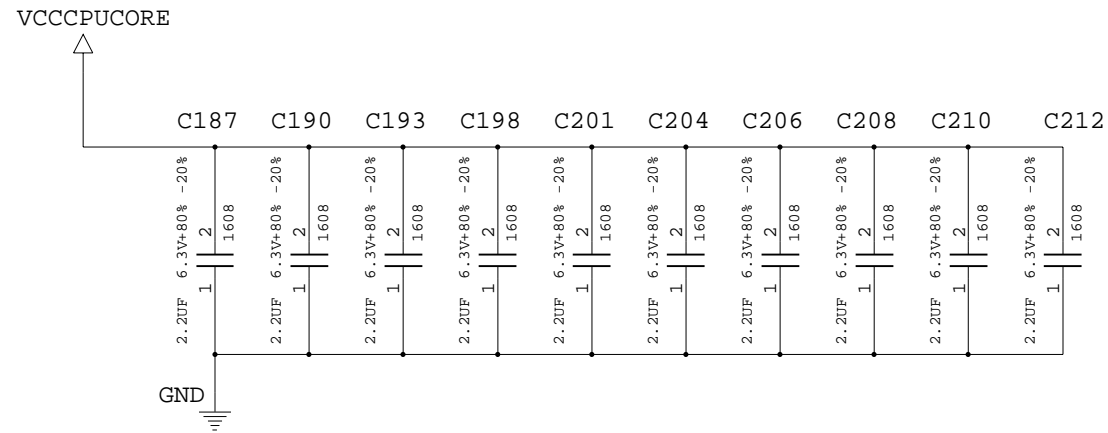

2.2UF X7R 1608 1/16W X15PCS
(X5R IS USED AT TOKYO-2)

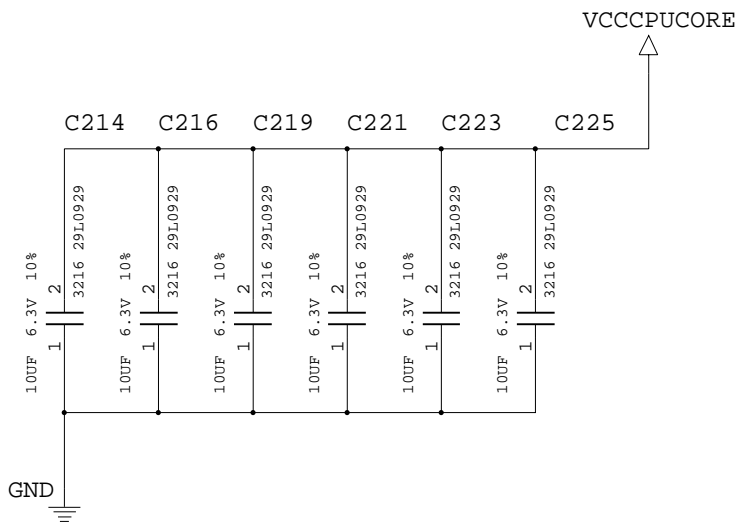
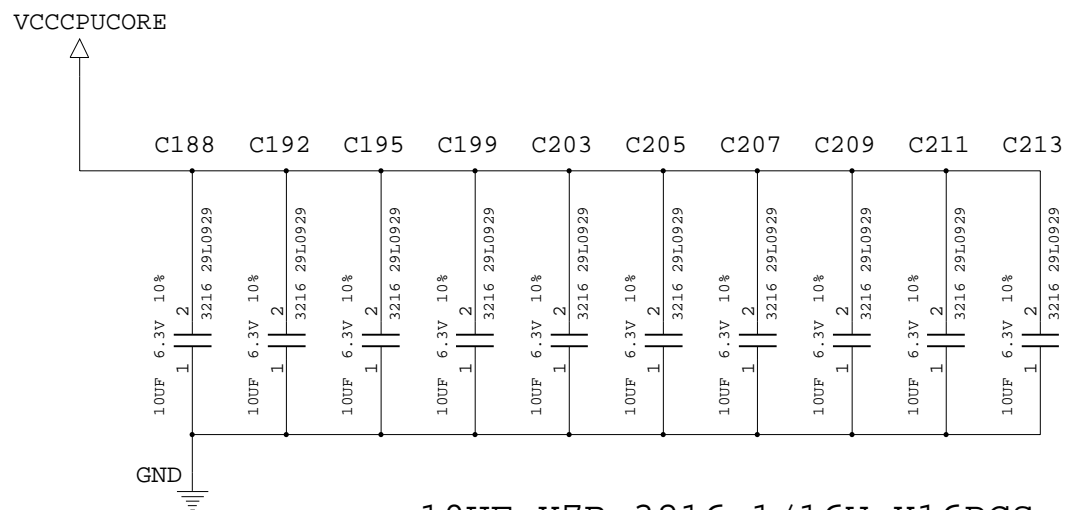

10UF X7R 3216 1/16W X16PCS
(X5R IS USED AT TOKYO-2)

93P4047

DESIGNER	Y.Y	06/12/03	PART NO.	93P4047	
CHECKED	Y.I	06/12/03	TITLE		
APPROVED	K.T	06/12/03	CLASS	CPU:DECAP(VCCCPUCORE)	
THIS DOCUMENT IS THE PROPERTY OF IBM ITS USE IS AUTHORIZED ONLY FOR RESPONDING TO A REQUEST FOR QUOTATION OR FOR THE PERFORMANCE OF WORK FOR IBM. ALL QUESTIONS MUST BE REFERRED TO THE IBM PURCHASING DEPARTMENT.				IBM CONFIDENTIAL	

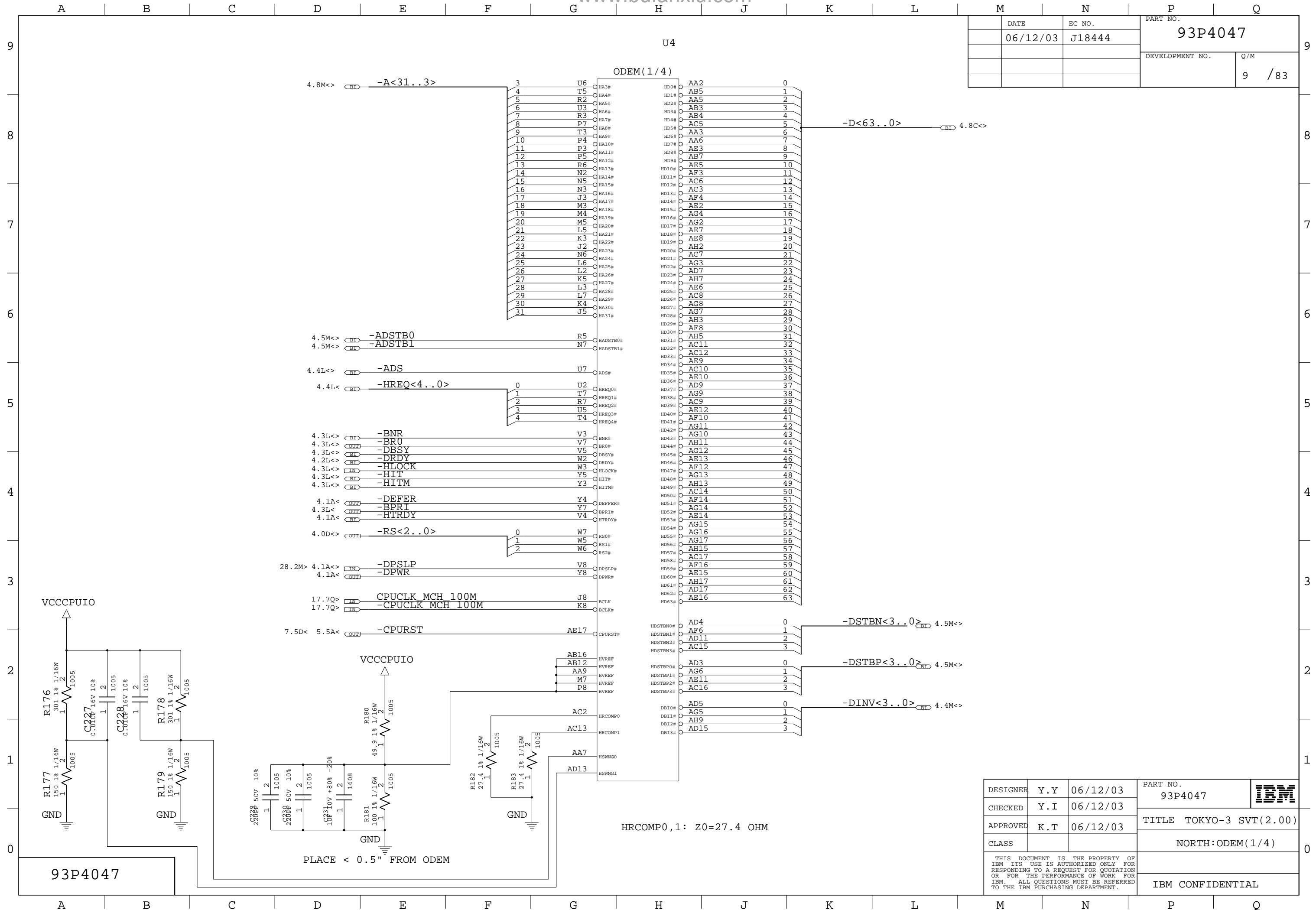

DATE	EC NO.	PART NO.	
06/12/03	J18444	93P4047	
		DEVELOPMENT NO.	Q/M
			9 / 83

DESIGNER	Y.Y	06/12/03	PART NO.	93P4047	
CHECKED	Y.I	06/12/03			
APPROVED	K.T	06/12/03	TITLE TOKYO-3 SVT(2.00)		
CLASS			NORTH:ODEM(1/4)		
THIS DOCUMENT IS THE PROPERTY OF IBM ITS USE IS AUTHORIZED ONLY FOR RESPONDING TO A REQUEST FOR QUOTATION OR FOR THE PERFORMANCE OF WORK FOR IBM. ALL QUESTIONS MUST BE REFERRED TO THE IBM PURCHASING DEPARTMENT.					IBM CONFIDENTIAL

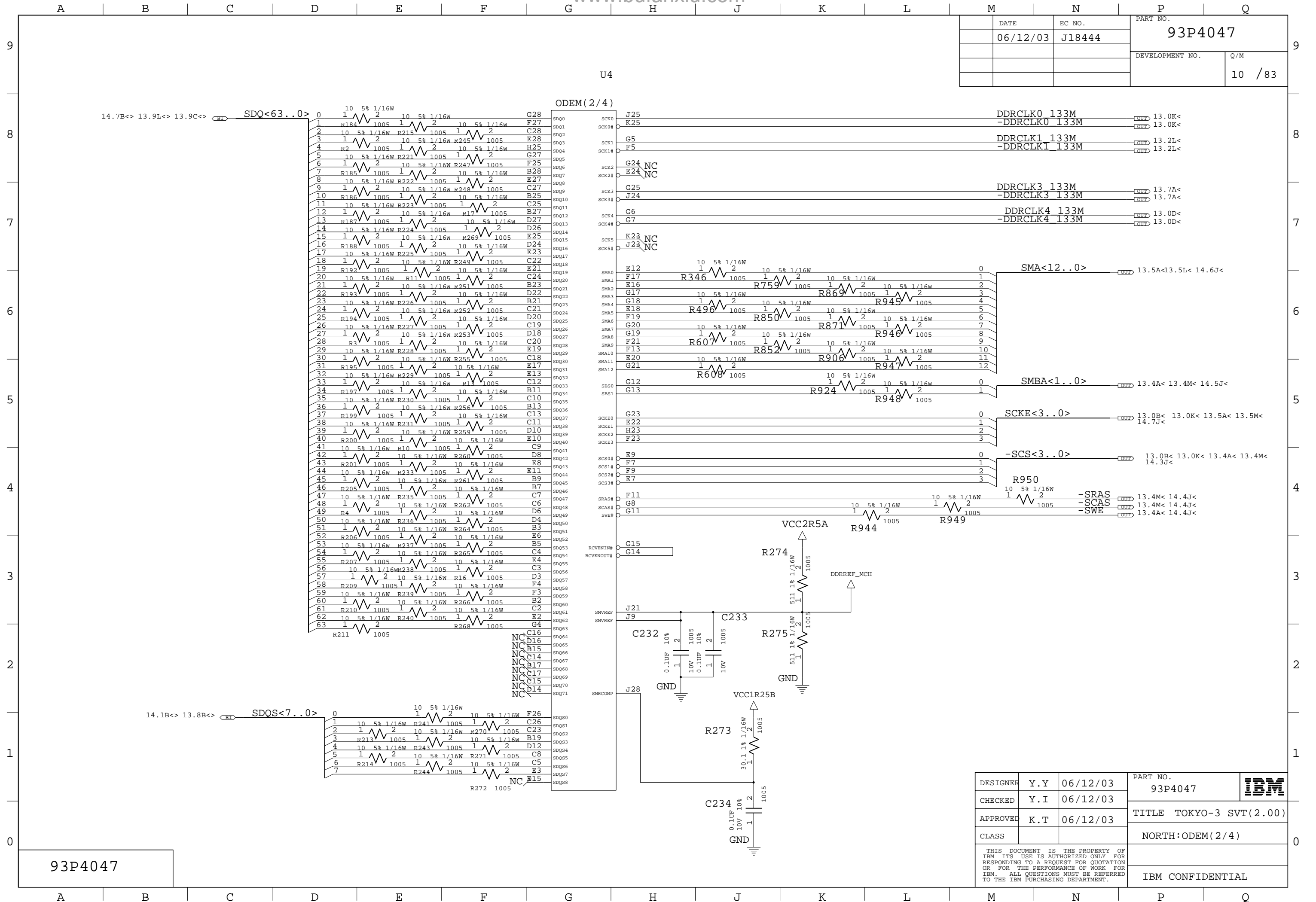

DATE	EC NO.	PART NO.	
06/12/03	J18444	93P4047	
		DEVELOPMENT NO.	Q/M
			10 /83

U4

ODEM(2/4)

93P4047

DESIGNER	Y.Y	06/12/03	PART NO.	93P4047	IBM
CHECKED	Y.I	06/12/03	TITLE TOKYO-3 SVT(2.00)		
APPROVED	K.T	06/12/03	NORTH:ODEM(2/4)		
CLASS					
THIS DOCUMENT IS THE PROPERTY OF IBM ITS USE IS AUTHORIZED ONLY FOR RESPONDING TO A REQUEST FOR QUOTATION OR FOR THE PERFORMANCE OF WORK FOR IBM. ALL QUESTIONS MUST BE REFERRED TO THE IBM PURCHASING DEPARTMENT.					IBM CONFIDENTIAL

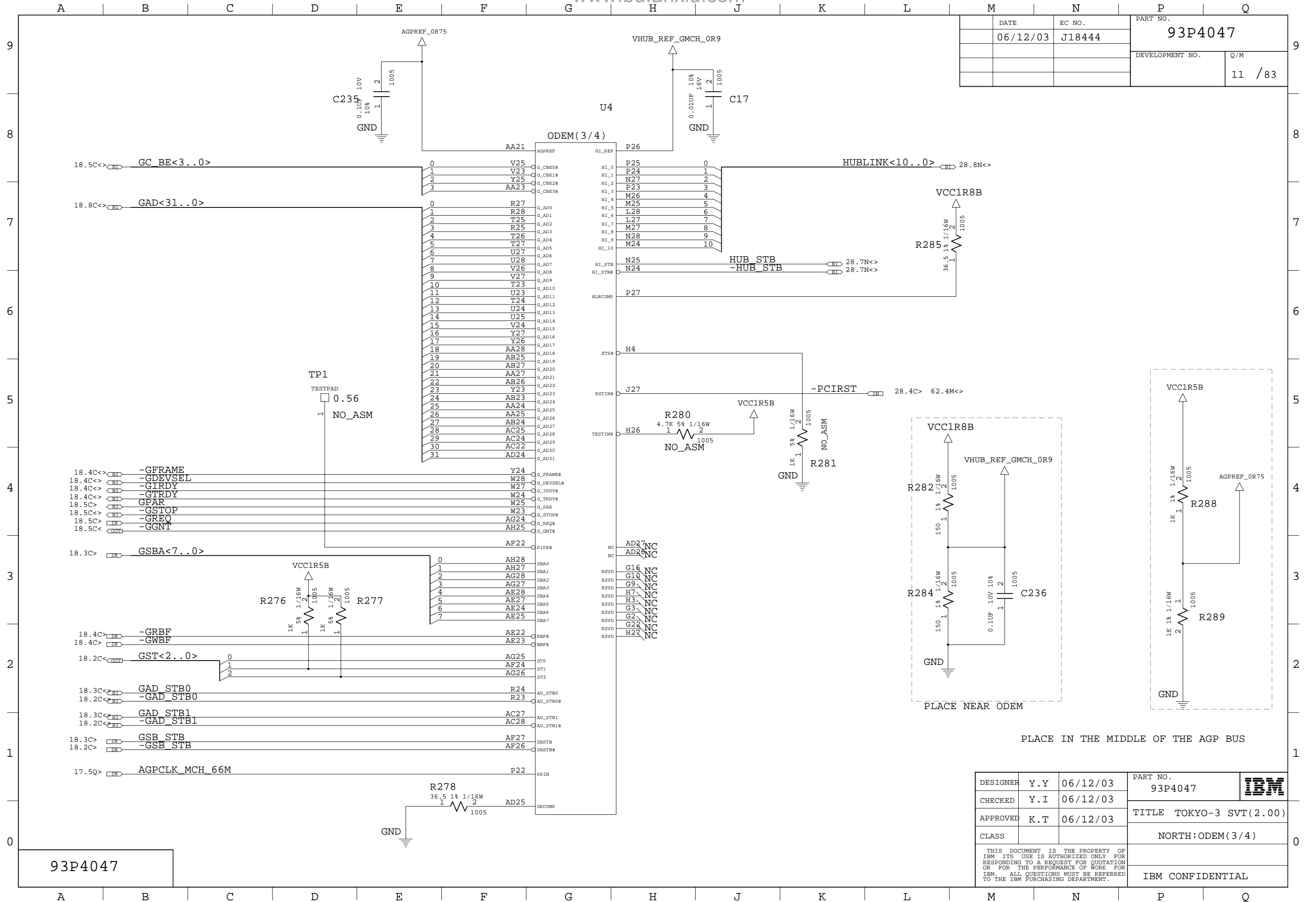

DATE	EC NO.	PART NO.	
06/12/03	J18444	93P4047	
		DEVELOPMENT NO.	Q/M
			11 / 83

DESIGNER	Y.Y	06/12/03	PART NO.	93P4047	IBM
CHECKED	Y.I	06/12/03	TITLE TOKYO-3 SVT(2.00)		
APPROVED	K.T	06/12/03	NORTH:ODEM(3/4)		
CLASS			THIS DOCUMENT IS THE PROPERTY OF IBM ITS USE IS AUTHORIZED ONLY FOR RESPONDING TO A REQUEST FOR QUOTATION OR FOR THE PERFORMANCE OF WORK FOR IBM. ALL QUESTIONS MUST BE REFERRED TO THE IBM PURCHASING DEPARTMENT.		IBM CONFIDENTIAL

93P4047

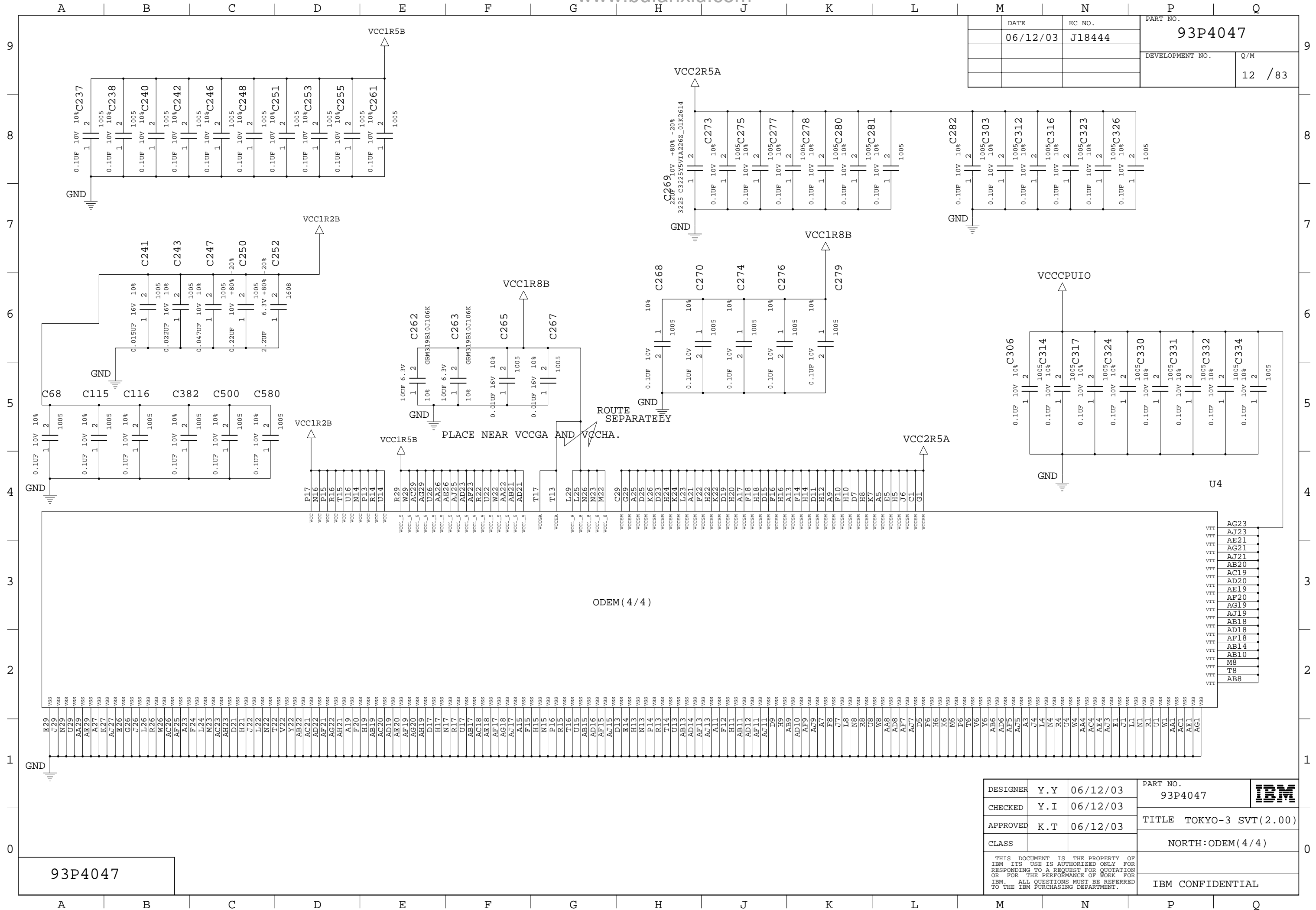

DATE	EC NO.	PART NO.
06/12/03	J18444	93P4047
DEVELOPMENT NO.		Q/M
		12 / 83

ODEM (4/4)

93P4047

DESIGNER	Y.Y	06/12/03	PART NO.	93P4047	
CHECKED	Y.I	06/12/03	TITLE TOKYO-3 SVT(2.00)		
APPROVED	K.T	06/12/03	NORTH:ODEM(4/4)		
CLASS			IBM CONFIDENTIAL		

THIS DOCUMENT IS THE PROPERTY OF IBM ITS USE IS AUTHORIZED ONLY FOR RESPONDING TO A REQUEST FOR QUOTATION OR FOR THE PERFORMANCE OF WORK FOR IBM. ALL QUESTIONS MUST BE REFERRED TO THE IBM PURCHASING DEPARTMENT.

- VTT AG23
- VTT AJ23
- VTT AE21
- VTT AG21
- VTT AJ21
- VTT AB20
- VTT AC19
- VTT AD20
- VTT AE19
- VTT AF20
- VTT AG19
- VTT AJ19
- VTT AB18
- VTT AD18
- VTT AF18
- VTT AB10
- VTT M8
- VTT T8
- VTT AB8

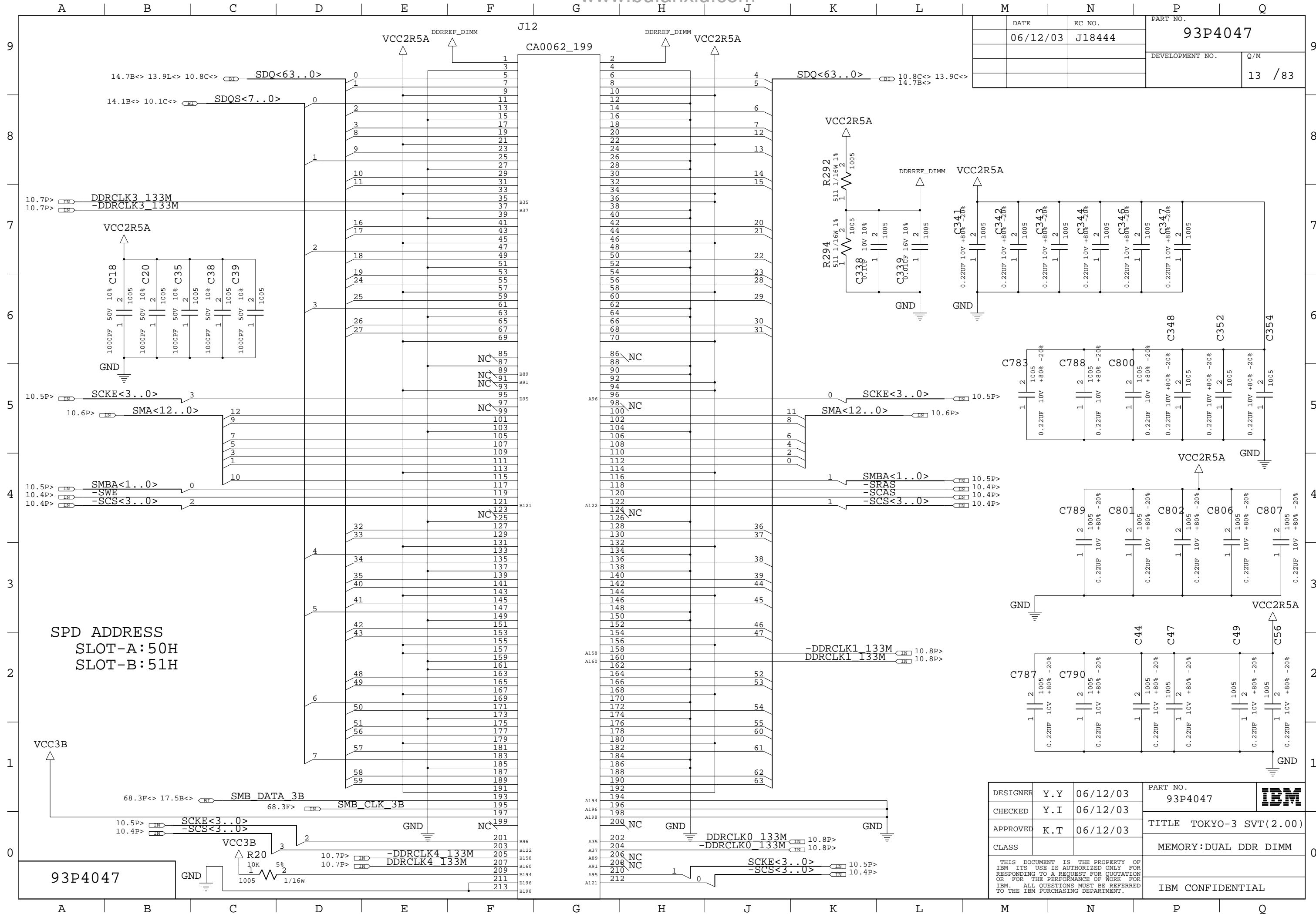

DATE	EC NO.	PART NO.
06/12/03	J18444	93P4047
DEVELOPMENT NO.		Q/M
		13 / 83

DESIGNER	Y.Y	06/12/03	PART NO.	93P4047	
CHECKED	Y.I	06/12/03	TITLE TOKYO-3 SVT(2.00)		
APPROVED	K.T	06/12/03	MEMORY:DUAL DDR DIMM		THIS DOCUMENT IS THE PROPERTY OF IBM ITS USE IS AUTHORIZED ONLY FOR RESPONDING TO A REQUEST FOR QUOTATION OR FOR THE PERFORMANCE OF WORK FOR IBM. ALL QUESTIONS MUST BE REFERRED TO THE IBM PURCHASING DEPARTMENT.
CLASS			IBM CONFIDENTIAL		

93P4047

SPD ADDRESS
 SLOT-A: 50H
 SLOT-B: 51H

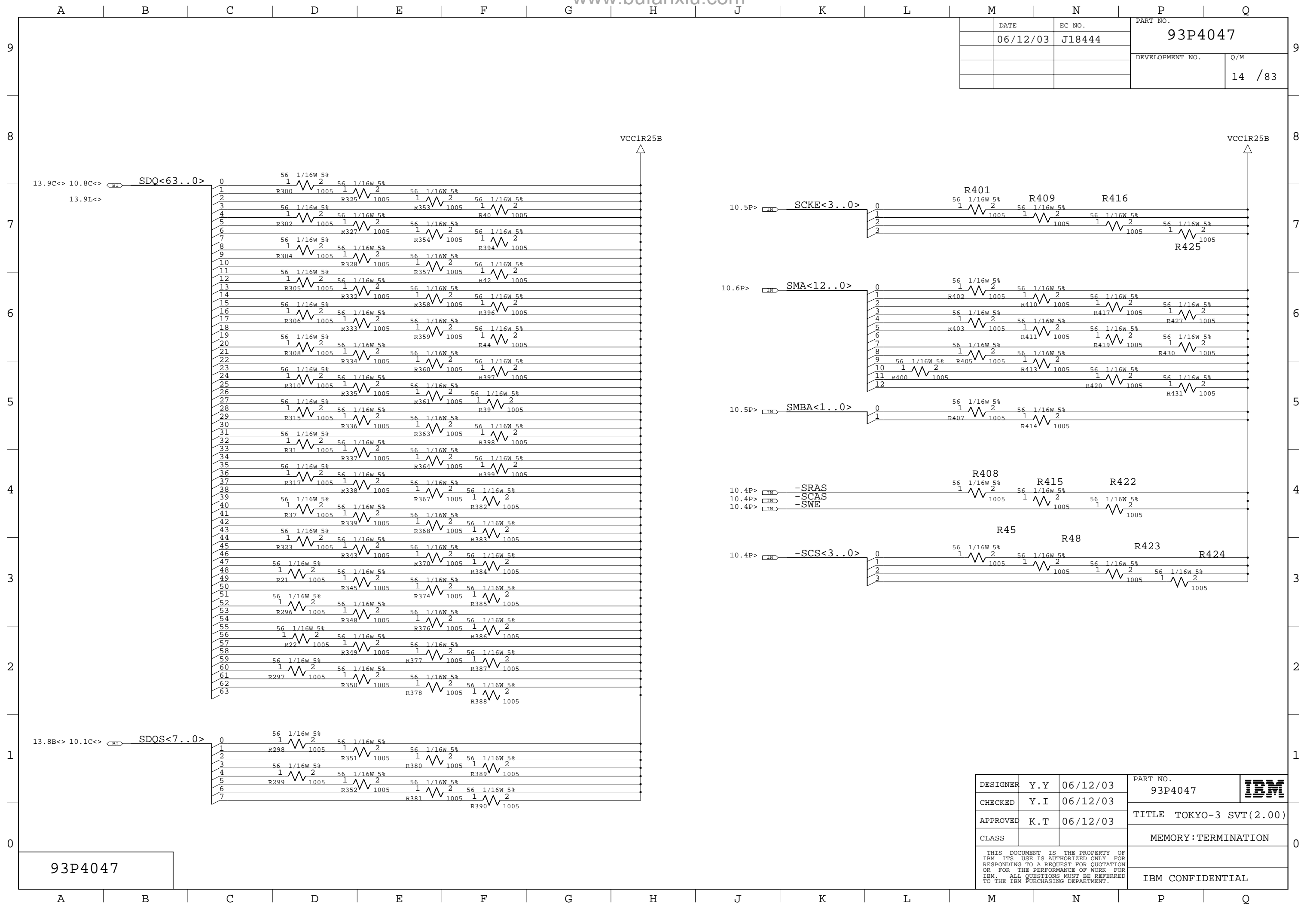

DATE	EC NO.	PART NO.	
06/12/03	J18444	93P4047	
		DEVELOPMENT NO.	Q/M
			14 /83

93P4047

DESIGNER	Y.Y	06/12/03	PART NO.	93P4047	
CHECKED	Y.I	06/12/03	TITLE		
APPROVED	K.T	06/12/03	CLASS	MEMORY:TERMINATION	
THIS DOCUMENT IS THE PROPERTY OF IBM ITS USE IS AUTHORIZED ONLY FOR RESPONDING TO A REQUEST FOR QUOTATION OR FOR THE PERFORMANCE OF WORK FOR IBM. ALL QUESTIONS MUST BE REFERRED TO THE IBM PURCHASING DEPARTMENT.					IBM CONFIDENTIAL

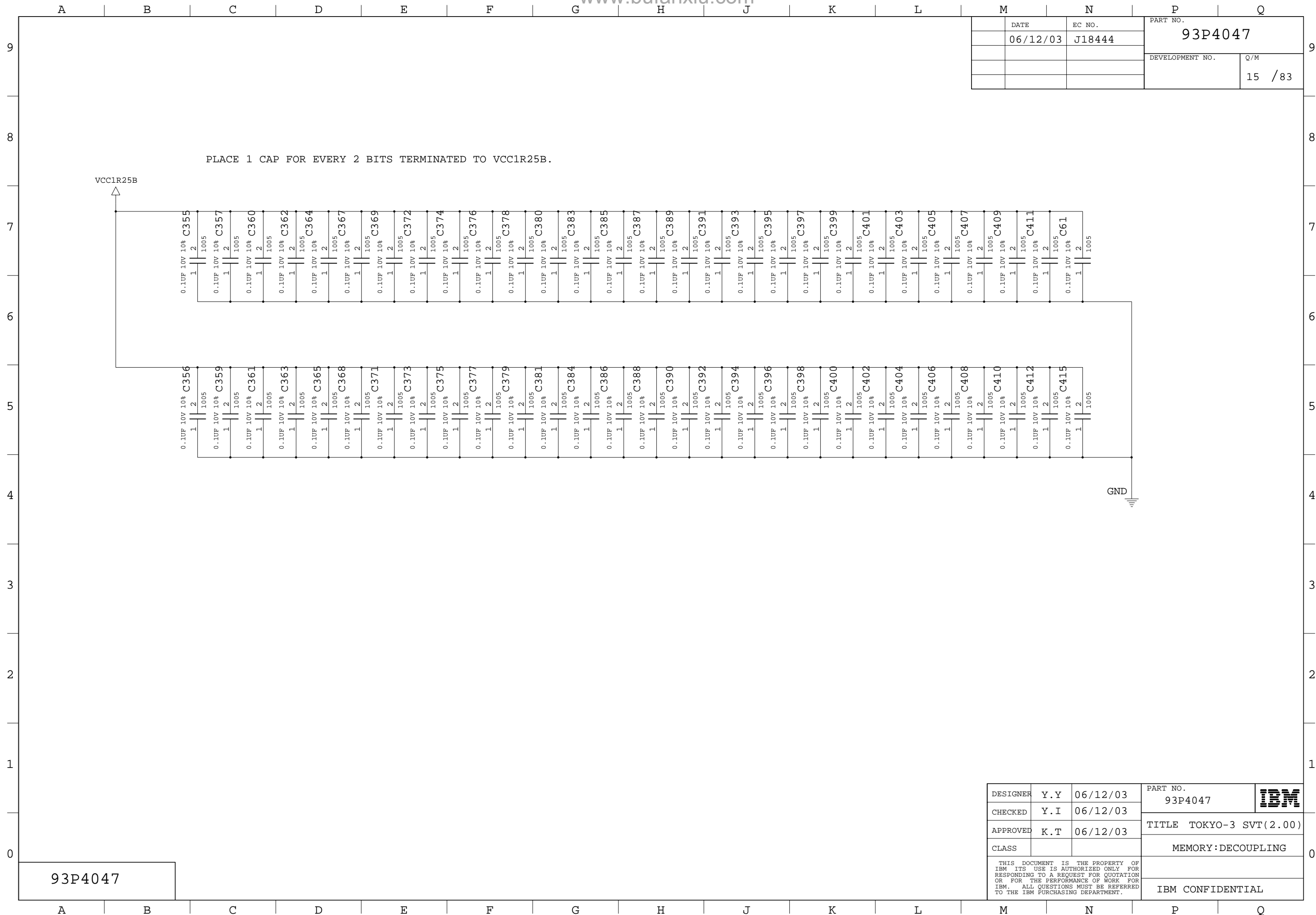

DATE	EC NO.	PART NO.	
06/12/03	J18444	93P4047	
		DEVELOPMENT NO.	Q/M
			15 /83

93P4047

DESIGNER	Y.Y	06/12/03	PART NO.	93P4047	
CHECKED	Y.I	06/12/03	TITLE		
APPROVED	K.T	06/12/03	CLASS	MEMORY:DECOUPLING	
THIS DOCUMENT IS THE PROPERTY OF IBM ITS USE IS AUTHORIZED ONLY FOR RESPONDING TO A REQUEST FOR QUOTATION OR FOR THE PERFORMANCE OF WORK FOR IBM. ALL QUESTIONS MUST BE REFERRED TO THE IBM PURCHASING DEPARTMENT.					IBM CONFIDENTIAL

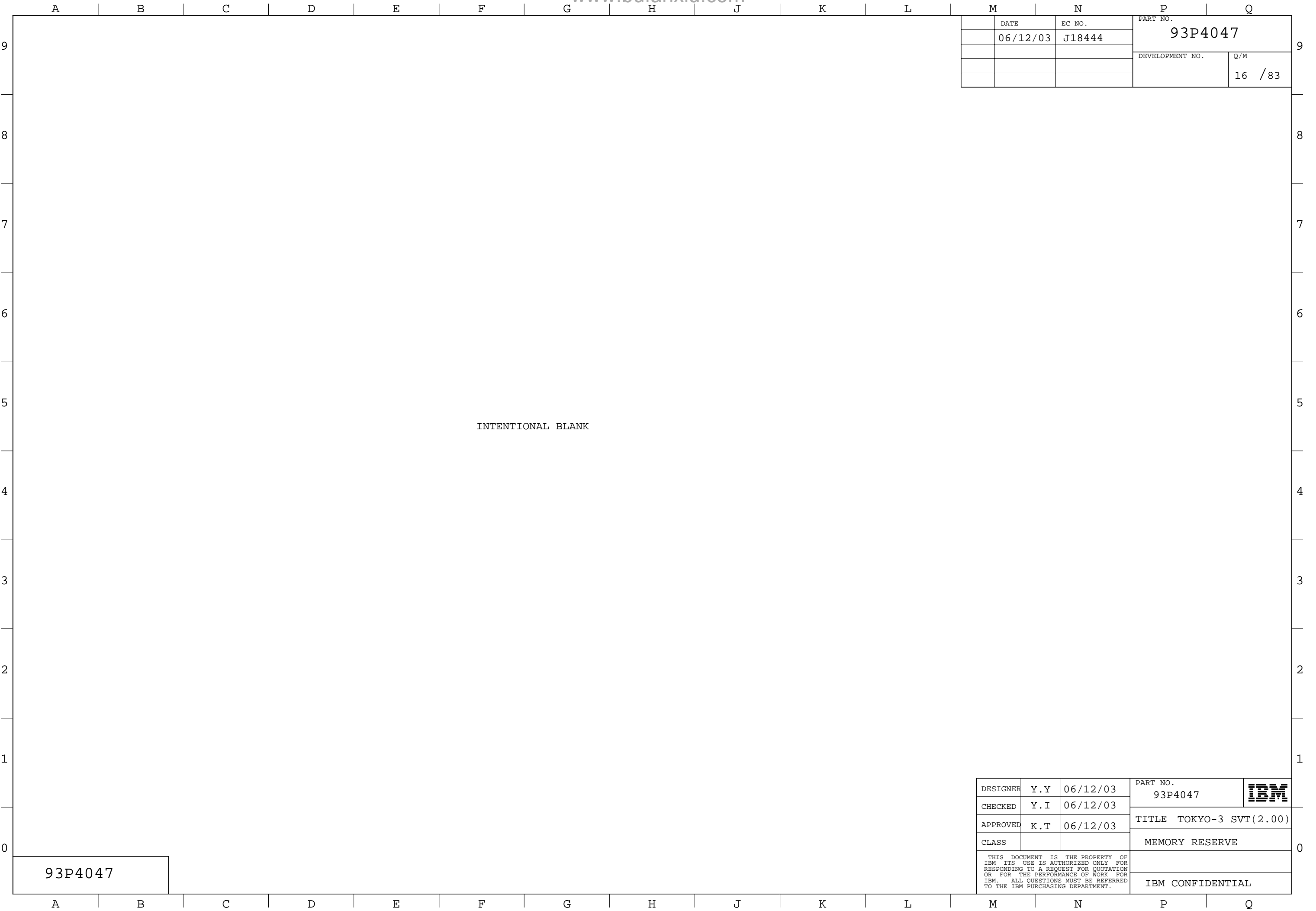

	DATE	EC NO.	PART NO.	
	06/12/03	J18444	93P4047	
			DEVELOPMENT NO.	Q/M
				16 /83

INTENTIONAL BLANK

93P4047

DESIGNER	Y.Y	06/12/03	PART NO.	
CHECKED	Y.I	06/12/03	93P4047	
APPROVED	K.T	06/12/03	TITLE TOKYO-3 SVT(2.00)	
CLASS			MEMORY RESERVE	
THIS DOCUMENT IS THE PROPERTY OF IBM ITS USE IS AUTHORIZED ONLY FOR RESPONDING TO A REQUEST FOR QUOTATION OR FOR THE PERFORMANCE OF WORK FOR IBM. ALL QUESTIONS MUST BE REFERRED TO THE IBM PURCHASING DEPARTMENT.			IBM CONFIDENTIAL	

DATE	EC NO.	PART NO.
06/12/03	J18444	93P4047
DEVELOPMENT NO.		Q/M
		17 /83

SEL1	SEL0	CPU
0	0	66M
0	1	100M
1	0	200M
1	1	133M

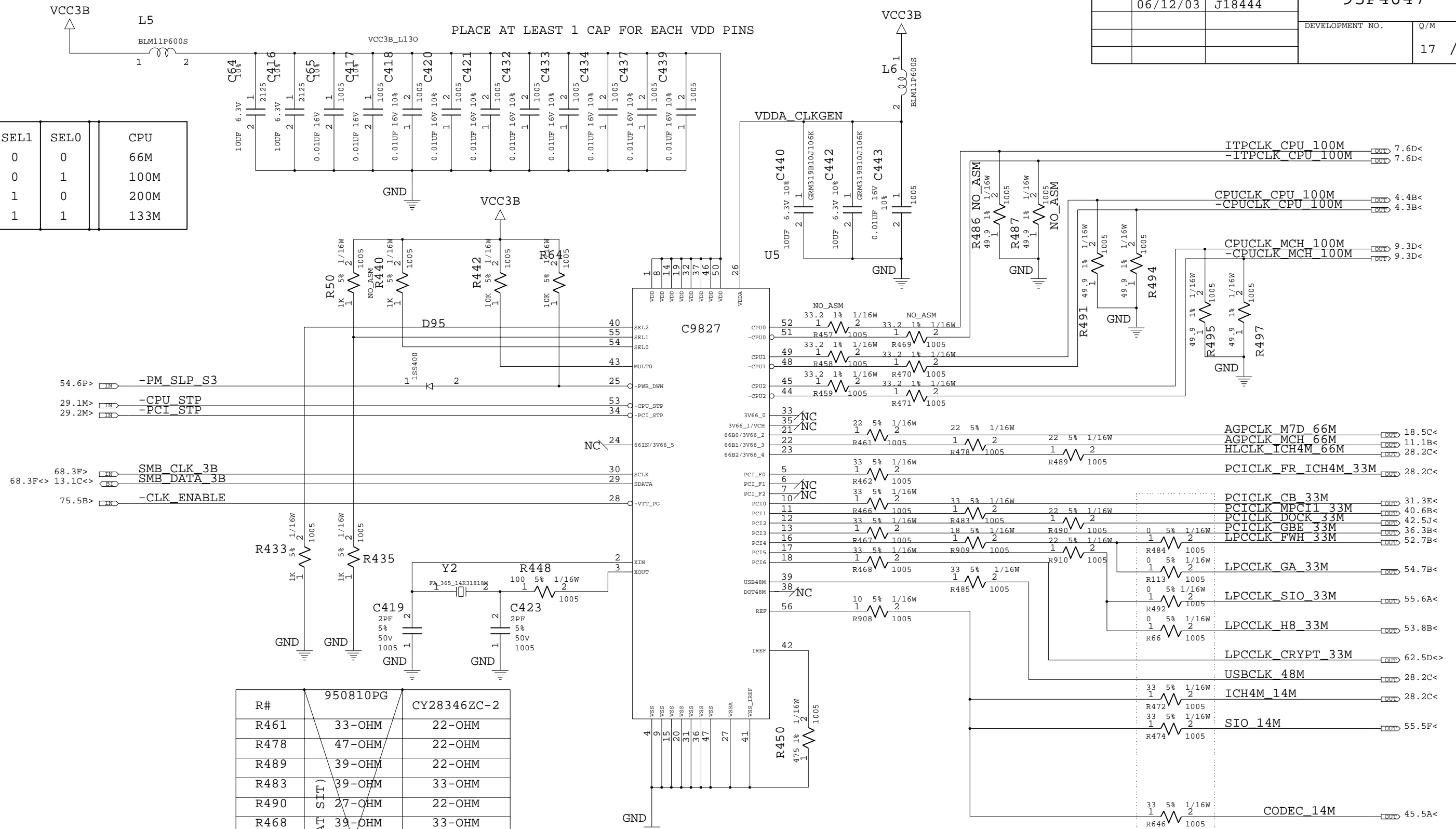

R#	950810PG	CY28346ZC-2
R461	33-OHM	22-OHM
R478	47-OHM	22-OHM
R489	39-OHM	22-OHM
R483	39-OHM	33-OHM
R490	27-OHM	22-OHM
R468	39-OHM	33-OHM
R909	22-OHM	18-OHM
R484	22-OHM	0-OHM
R113	22-OHM	0-OHM
R910	33-OHM	22-OHM
R908	10-OHM	10-OHM
R472	68-OHM	33-OHM
R474	68-OHM	33-OHM
R646	68-OHM	33-OHM

Y2	CY28346ZC-2	950810PG
FA-365	CL=16PF	CL=16PF
CS10	CL=17PF	CL=12PF
FCX-03	CL=16PF	CL=16PF

(NOT USE AT SIT)

NEAR DEVICES

DESIGNER	Y.Y	06/12/03	PART NO.	93P4047	IBM
CHECKED	Y.I	06/12/03	TITLE TOKYO-3 SVT(2.00)		
APPROVED	K.T	06/12/03	CLOCK GENERATOR:CK-408		
CLASS					

THIS DOCUMENT IS THE PROPERTY OF IBM ITS USE IS AUTHORIZED ONLY FOR RESPONDING TO A REQUEST FOR QUOTATION OR FOR THE PERFORMANCE OF WORK FOR IBM. ALL QUESTIONS MUST BE REFERRED TO THE IBM PURCHASING DEPARTMENT.

IBM CONFIDENTIAL

93P4047

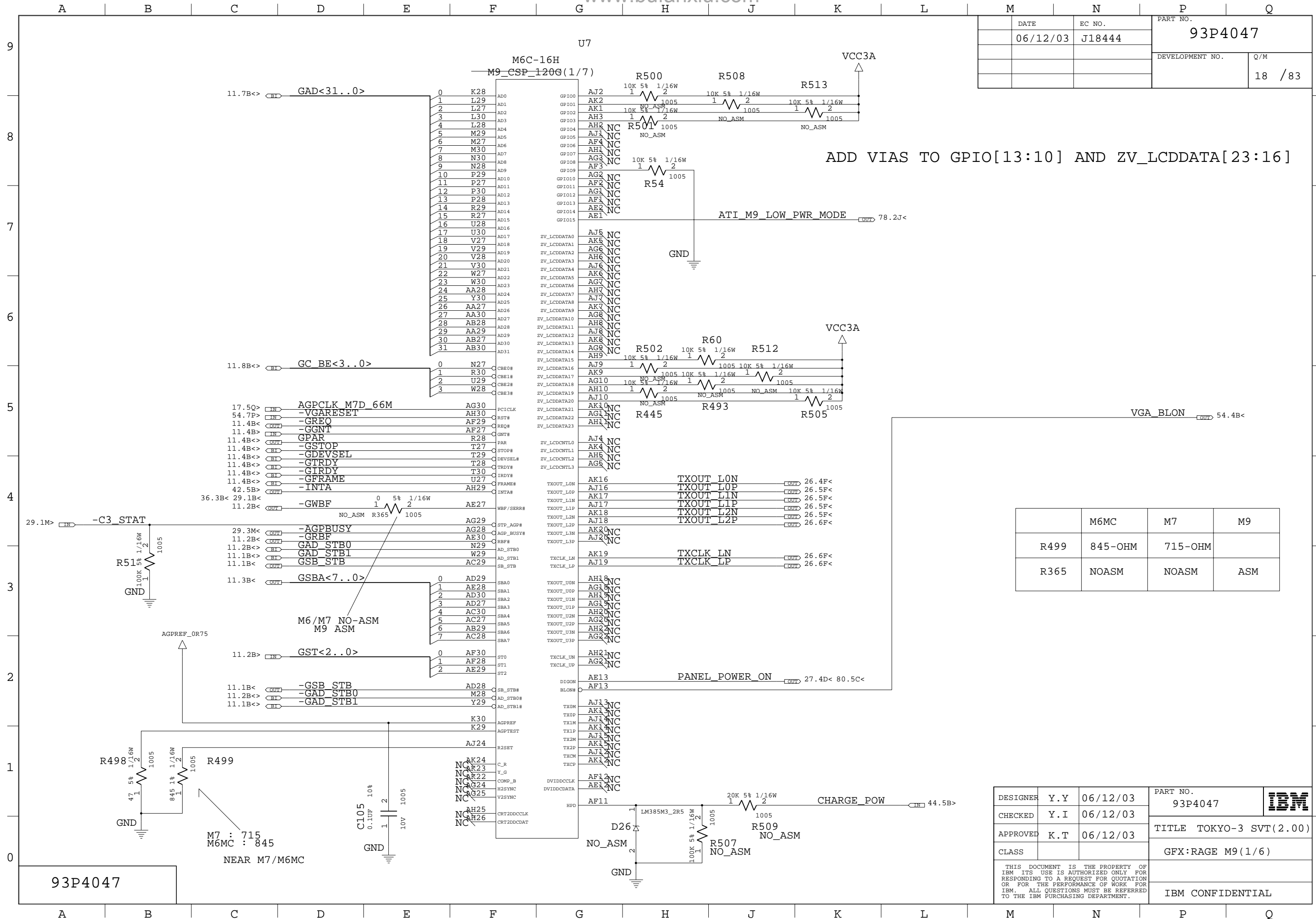

DATE	EC NO.	PART NO.	
06/12/03	J18444	93P4047	
		DEVELOPMENT NO.	Q/M
			18 /83

ADD VIAS TO GPIO[13:10] AND ZV_LCDDATA[23:16]

	M6MC	M7	M9
R499	845-OHM	715-OHM	
R365	NOASM	NOASM	ASM

DESIGNER	Y.Y	06/12/03	PART NO.	93P4047	
CHECKED	Y.I	06/12/03	TITLE		
APPROVED	K.T	06/12/03	CLASS	GFY:RAGE M9(1/6)	
THIS DOCUMENT IS THE PROPERTY OF IBM ITS USE IS AUTHORIZED ONLY FOR RESPONDING TO A REQUEST FOR QUOTATION OR FOR THE PERFORMANCE OF WORK FOR IBM. ALL QUESTIONS MUST BE REFERRED TO THE IBM PURCHASING DEPARTMENT.				IBM CONFIDENTIAL	

93P4047

DATE	EC NO.	PART NO.
06/12/03	J18444	93P4047
DEVELOPMENT NO.		Q/M
		19 /83

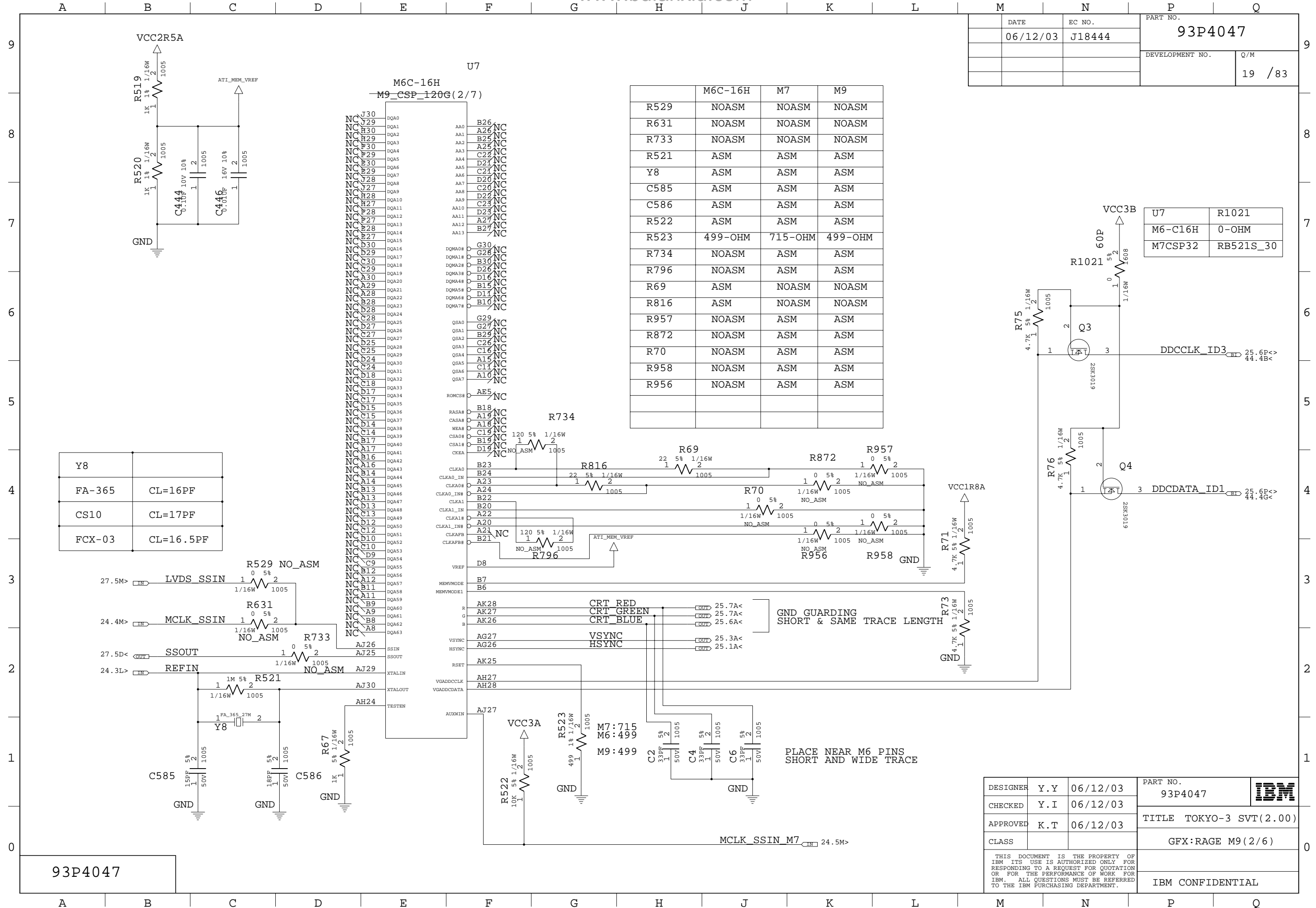

	M6C-16H	M7	M9
R529	NOASM	NOASM	NOASM
R631	NOASM	NOASM	NOASM
R733	NOASM	NOASM	NOASM
R521	ASM	ASM	ASM
Y8	ASM	ASM	ASM
C585	ASM	ASM	ASM
C586	ASM	ASM	ASM
R522	ASM	ASM	ASM
R523	499-OHM	715-OHM	499-OHM
R734	NOASM	ASM	ASM
R796	NOASM	ASM	ASM
R69	ASM	NOASM	NOASM
R816	ASM	NOASM	NOASM
R957	NOASM	ASM	ASM
R872	NOASM	ASM	ASM
R70	NOASM	ASM	ASM
R958	NOASM	ASM	ASM
R956	NOASM	ASM	ASM

Y8	
FA-365	CL=16PF
CS10	CL=17PF
FCX-03	CL=16.5PF

U7	R1021
M6-C16H	0-OHM
M7CSP32	RB521S_30

GND GUARDING
SHORT & SAME TRACE LENGTH

PLACE NEAR M6 PINS
SHORT AND WIDE TRACE

93P4047

DESIGNER	Y.Y	06/12/03	PART NO.	93P4047	
CHECKED	Y.I	06/12/03	TITLE TOKYO-3 SVT(2.00)		
APPROVED	K.T	06/12/03	CLASS		GFY:RAGE M9(2/6)
THIS DOCUMENT IS THE PROPERTY OF IBM ITS USE IS AUTHORIZED ONLY FOR RESPONDING TO A REQUEST FOR QUOTATION OR FOR THE PERFORMANCE OF WORK FOR IBM. ALL QUESTIONS MUST BE REFERRED TO THE IBM PURCHASING DEPARTMENT.					IBM CONFIDENTIAL

DATE	EC NO.	PART NO.	
06/12/03	J18444	93P4047	
		DEVELOPMENT NO.	Q/M
			20 /83

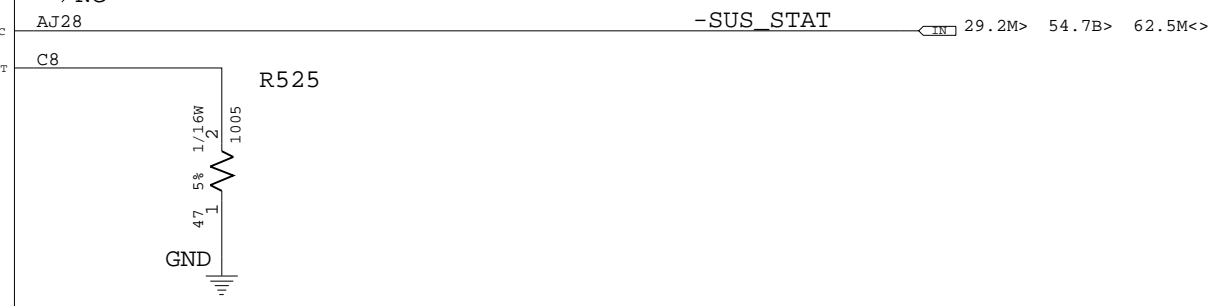
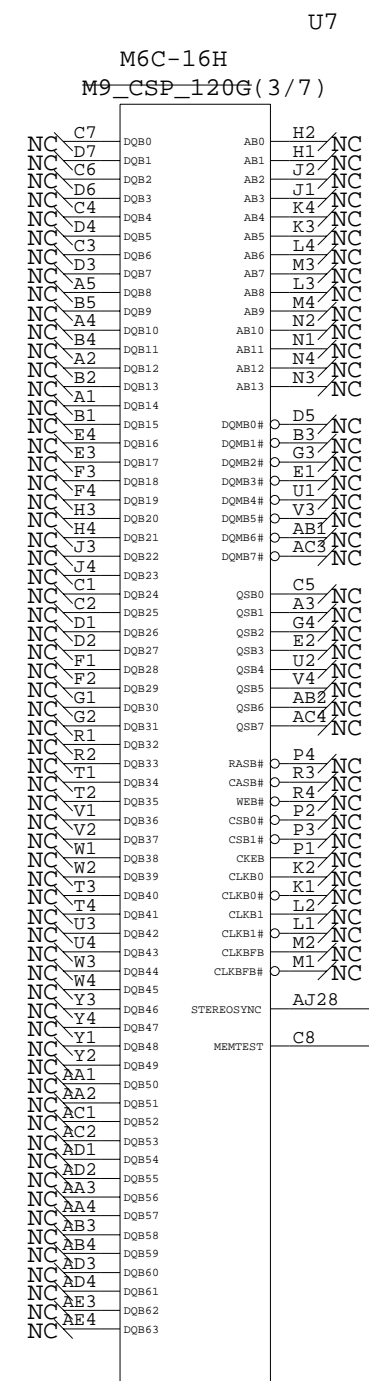

93P4047

DESIGNER	Y.Y	06/12/03	PART NO.	93P4047	IBM
CHECKED	Y.I	06/12/03	TITLE TOKYO-3 SVT(2.00)		
APPROVED	K.T	06/12/03	GFX:RAGE M9(3/6)		
CLASS			THIS DOCUMENT IS THE PROPERTY OF IBM ITS USE IS AUTHORIZED ONLY FOR RESPONDING TO A REQUEST FOR QUOTATION OR FOR THE PERFORMANCE OF WORK FOR IBM. ALL QUESTIONS MUST BE REFERRED TO THE IBM PURCHASING DEPARTMENT.		IBM CONFIDENTIAL

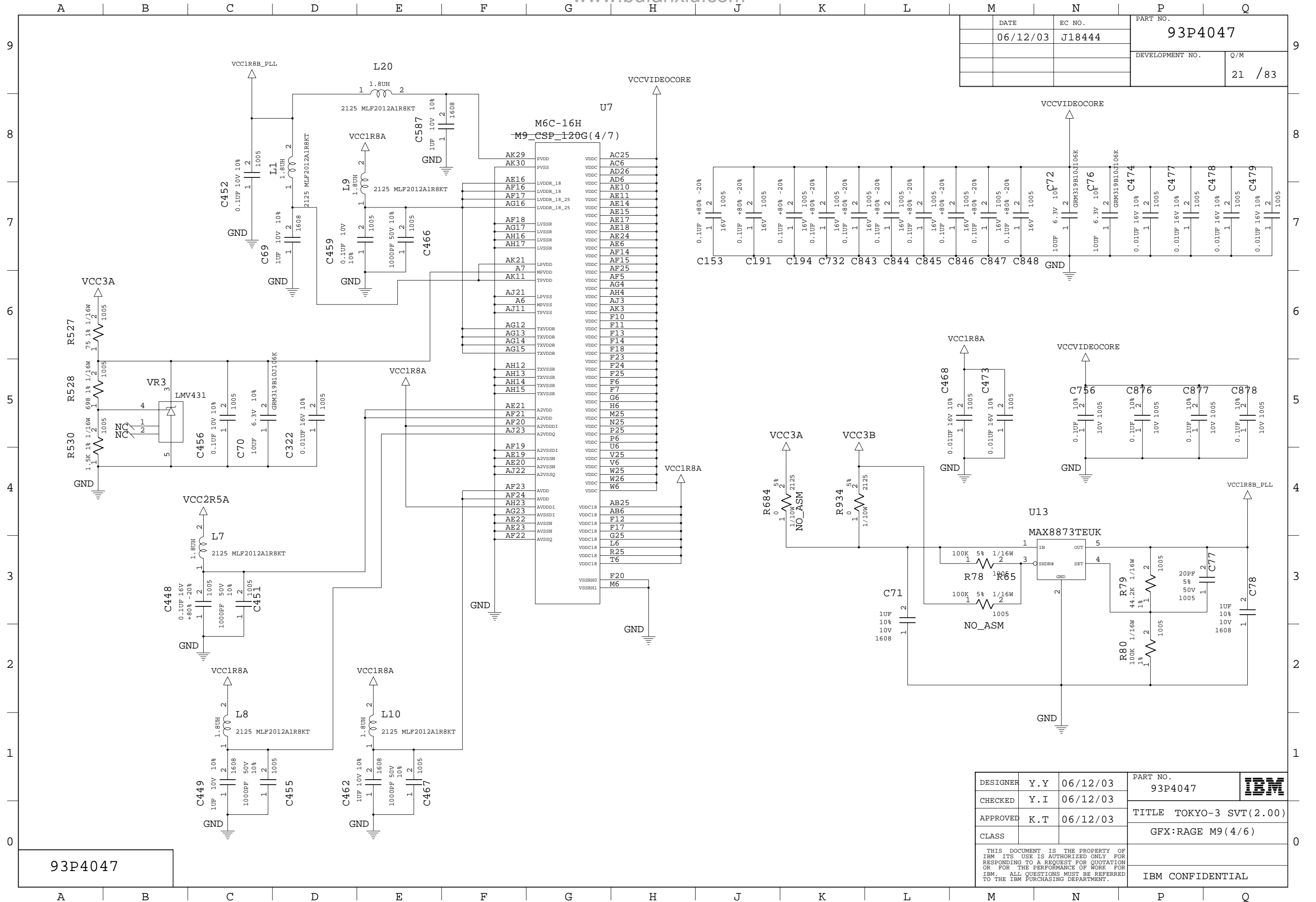

DATE	EC NO.	PART NO.
06/12/03	J18444	93P4047
DEVELOPMENT NO.		Q/M
		21 / 83

93P4047

DESIGNER	Y.Y	06/12/03	PART NO.	93P4047	
CHECKED	Y.I	06/12/03	TITLE TOKYO-3 SVT(2.00)		
APPROVED	K.T	06/12/03	GFX:RAGE M9(4/6)		
CLASS					
THIS DOCUMENT IS THE PROPERTY OF IBM ITS USE IS AUTHORIZED ONLY FOR RESPONDING TO A REQUEST FOR QUOTATION OR FOR THE PERFORMANCE OF WORK FOR IBM. ALL QUESTIONS MUST BE REFERRED TO THE IBM PURCHASING DEPARTMENT.					IBM CONFIDENTIAL

DATE	EC NO.	PART NO.	
06/12/03	J18444	93P4047	
		DEVELOPMENT NO.	Q/M
			22 /83

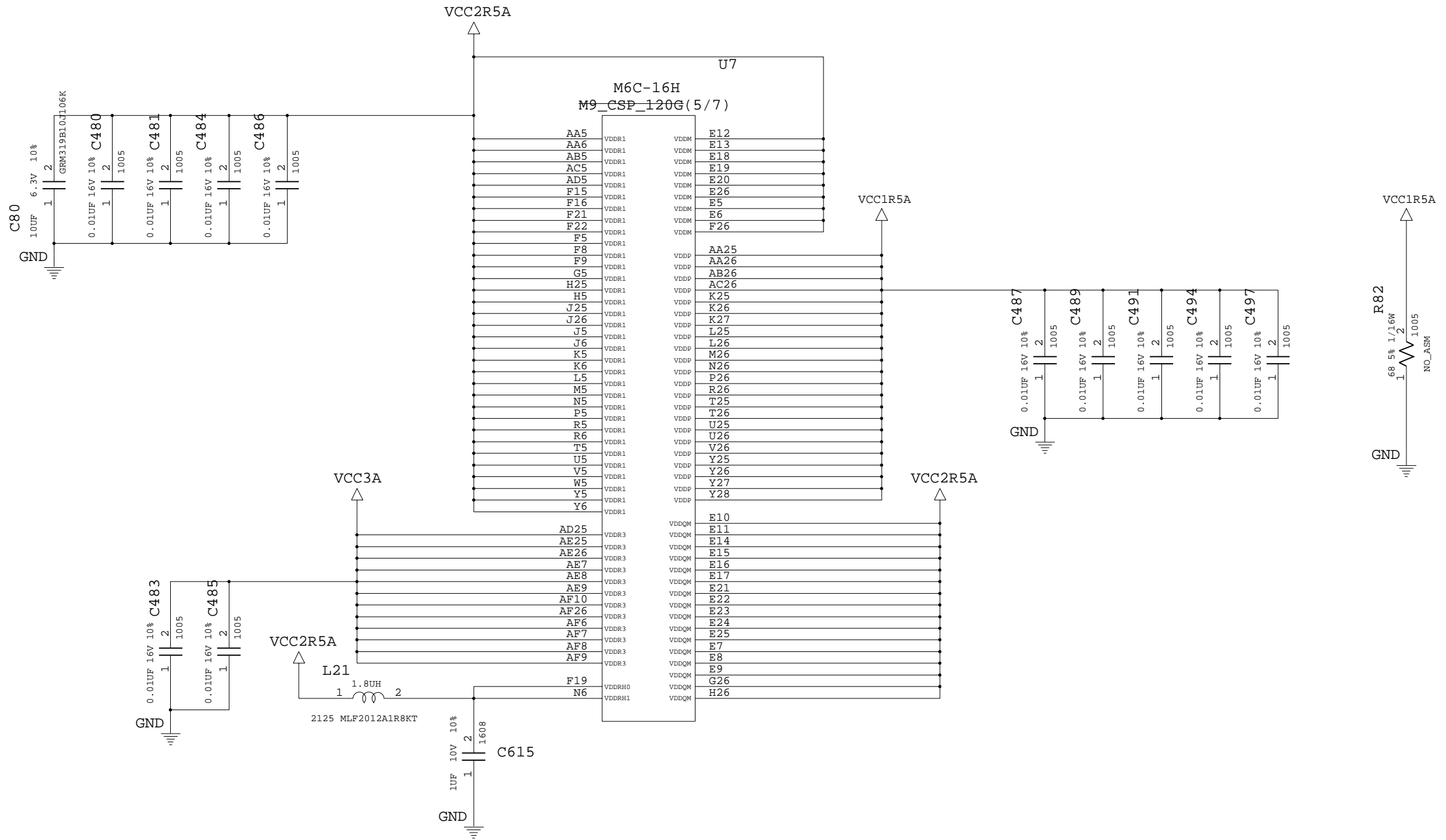

93P4047

DESIGNER	Y.Y	06/12/03	PART NO.	93P4047	
CHECKED	Y.I	06/12/03	TITLE		
APPROVED	K.T	06/12/03	CLASS	GFX:RAGE M9(5/6)	
THIS DOCUMENT IS THE PROPERTY OF IBM ITS USE IS AUTHORIZED ONLY FOR RESPONDING TO A REQUEST FOR QUOTATION OR FOR THE PERFORMANCE OF WORK FOR IBM. ALL QUESTIONS MUST BE REFERRED TO THE IBM PURCHASING DEPARTMENT.				IBM CONFIDENTIAL	

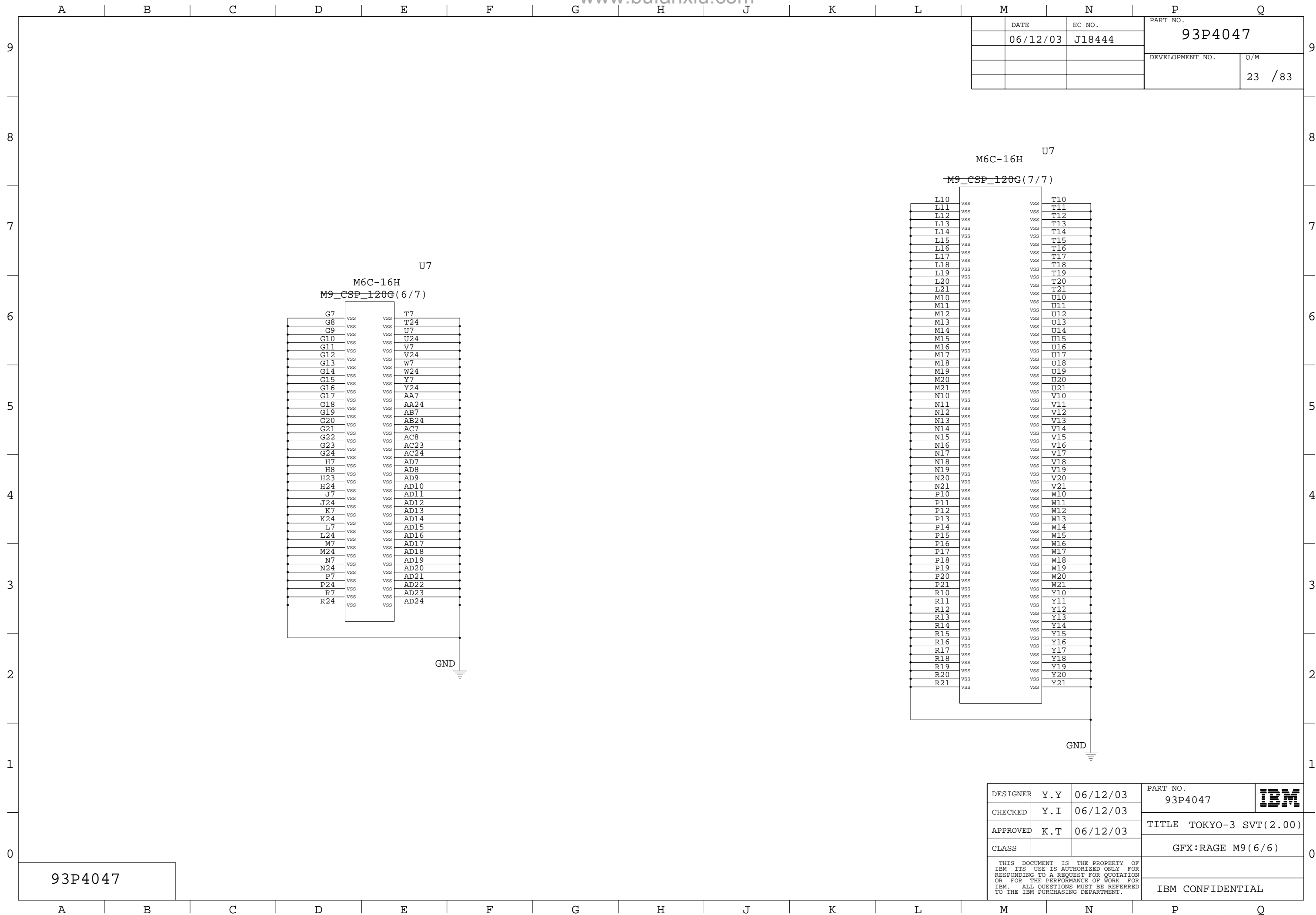

DATE	EC NO.	PART NO.	
06/12/03	J18444	93P4047	
		DEVELOPMENT NO.	Q/M
			23 /83

M6C-16H U7

M9_CSP_120G(7/7)

M6C-16H U7
M9_CSP_120G(6/7)

DESIGNER	Y.Y	06/12/03	PART NO.	93P4047	IBM
CHECKED	Y.I	06/12/03	TITLE		
APPROVED	K.T	06/12/03	CLASS	GFX:RAGE M9(6/6)	
THIS DOCUMENT IS THE PROPERTY OF IBM ITS USE IS AUTHORIZED ONLY FOR RESPONDING TO A REQUEST FOR QUOTATION OR FOR THE PERFORMANCE OF WORK FOR IBM. ALL QUESTIONS MUST BE REFERRED TO THE IBM PURCHASING DEPARTMENT.					IBM CONFIDENTIAL

93P4047

DATE		EC NO.		PART NO.	
06/12/03		J18444		93P4047	
DEVELOPMENT NO.				Q/M	
				24 /83	

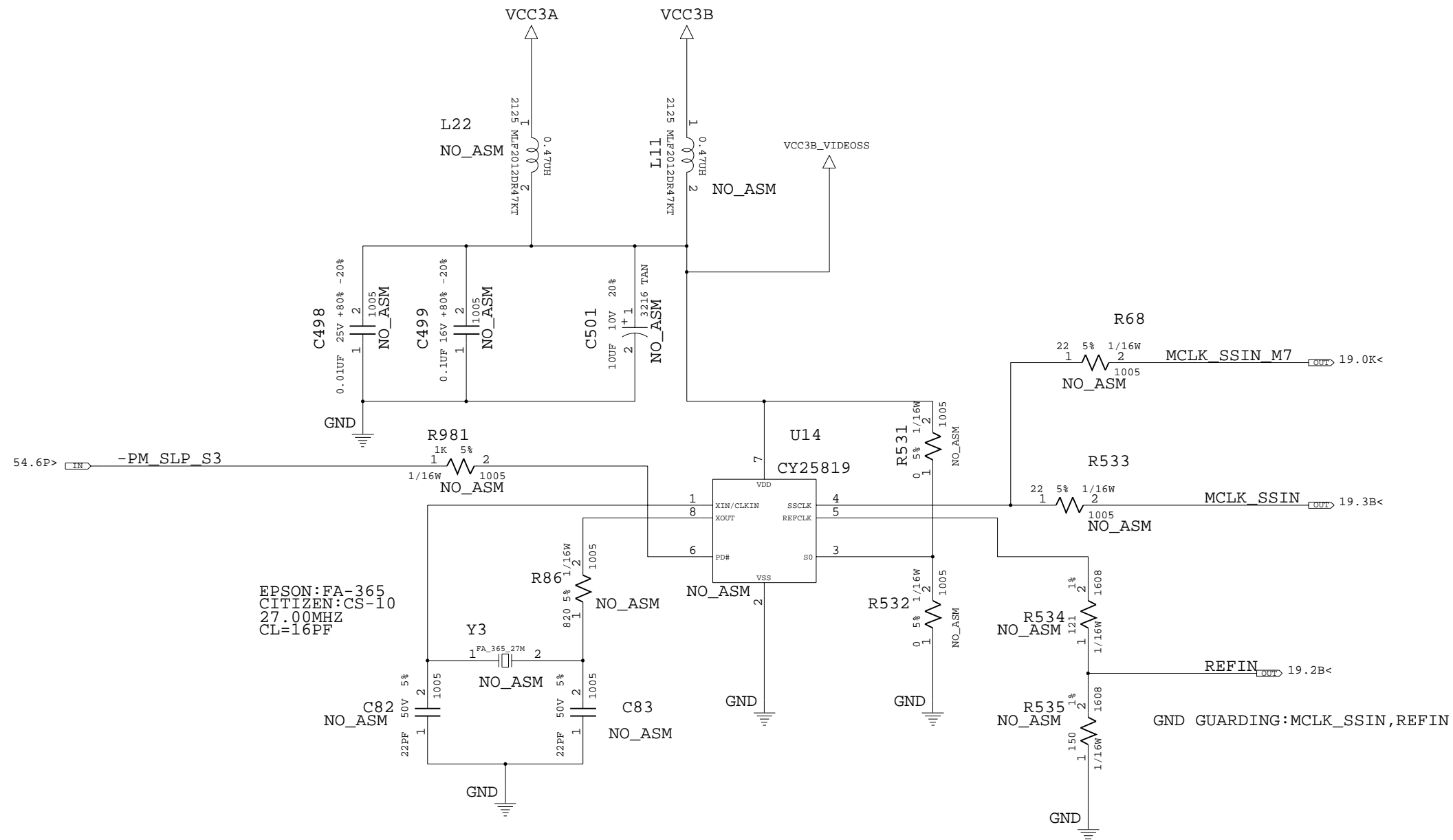

EPSON:FA-365
CITIZEN:CS-10
27.00MHZ
CL=16PF

(PAGE G1 ADDITIONAL)

93P4047

DESIGNER	Y.Y	06/12/03	PART NO.	93P4047	IBM
CHECKED	Y.I	06/12/03	TITLE TOKYO-3 SVT(2.00)		
APPROVED	K.T	06/12/03	GFX:CLOCK MODULATOR		
CLASS			THIS DOCUMENT IS THE PROPERTY OF IBM ITS USE IS AUTHORIZED ONLY FOR RESPONDING TO A REQUEST FOR QUOTATION OR FOR THE PERFORMANCE OF WORK FOR IBM. ALL QUESTIONS MUST BE REFERRED TO THE IBM PURCHASING DEPARTMENT.		IBM CONFIDENTIAL

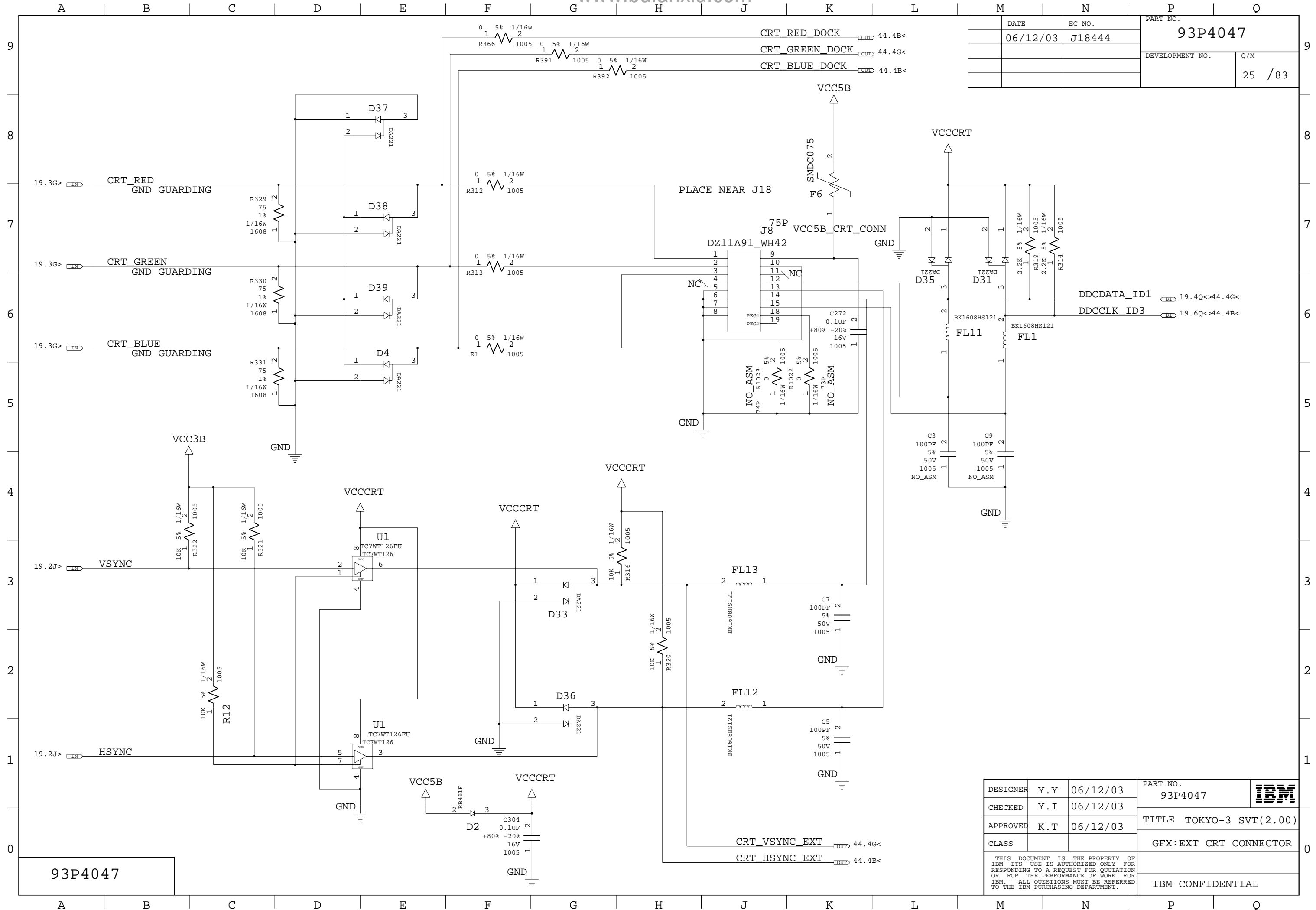

DATE	EC NO.	PART NO.
06/12/03	J18444	93P4047
DEVELOPMENT NO.		Q/M
		25 /83

93P4047

DESIGNER	Y.Y	06/12/03	PART NO.	93P4047	IBM
CHECKED	Y.I	06/12/03	TITLE TOKYO-3 SVT(2.00)		
APPROVED	K.T	06/12/03	CLASS		GFY:EXT CRT CONNECTOR
THIS DOCUMENT IS THE PROPERTY OF IBM ITS USE IS AUTHORIZED ONLY FOR RESPONDING TO A REQUEST FOR QUOTATION OR FOR THE PERFORMANCE OF WORK FOR IBM. ALL QUESTIONS MUST BE REFERRED TO THE IBM PURCHASING DEPARTMENT.					IBM CONFIDENTIAL

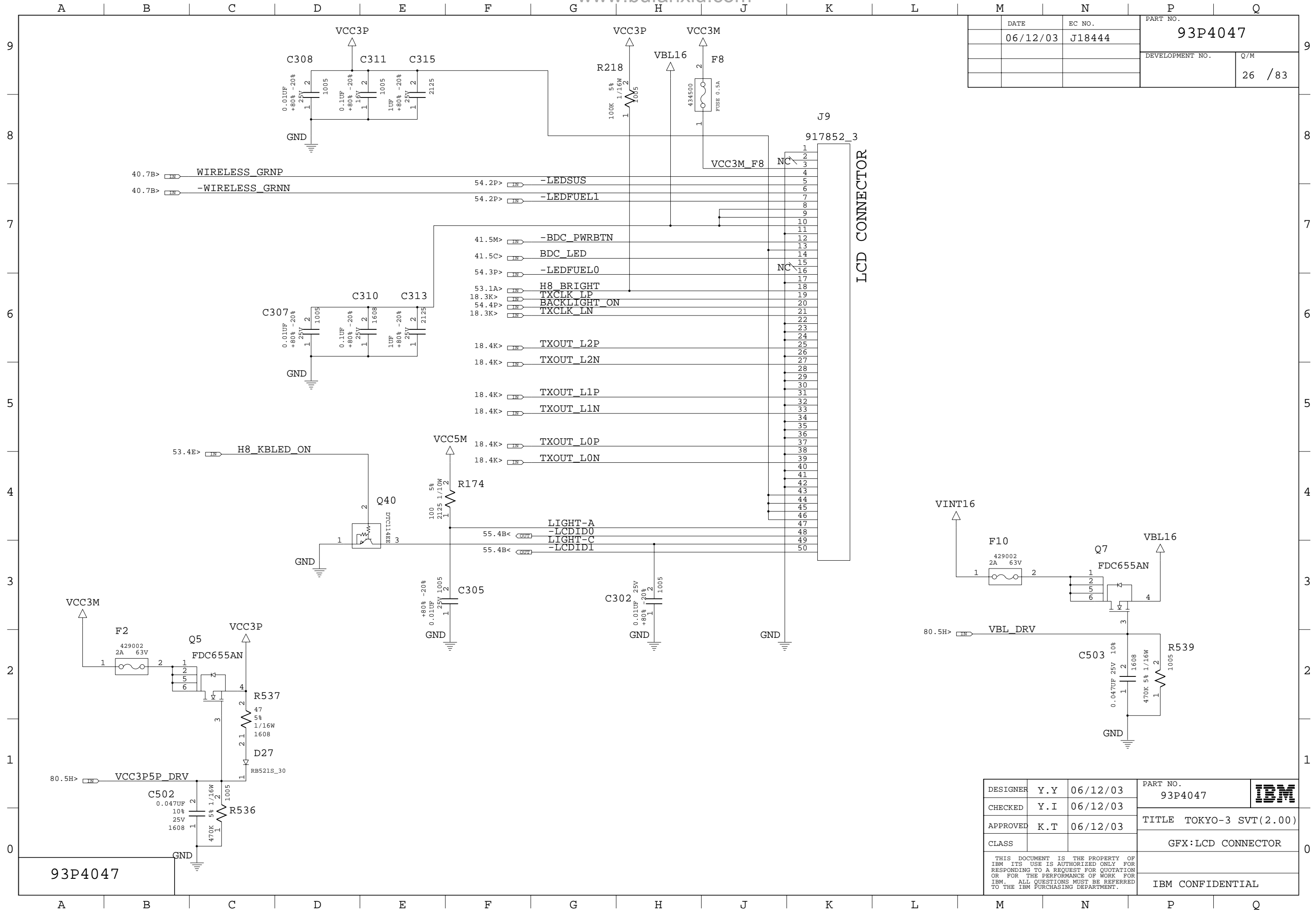

DATE	EC NO.	PART NO.
06/12/03	J18444	93P4047
		DEVELOPMENT NO.
		Q/M
		26 / 83

DESIGNER	Y.Y	06/12/03	PART NO.	93P4047	IBM
CHECKED	Y.I	06/12/03	TITLE TOKYO-3 SVT(2.00)		
APPROVED	K.T	06/12/03	GFX:LCD CONNECTOR		
CLASS					
THIS DOCUMENT IS THE PROPERTY OF IBM ITS USE IS AUTHORIZED ONLY FOR RESPONDING TO A REQUEST FOR QUOTATION OR FOR THE PERFORMANCE OF WORK FOR IBM. ALL QUESTIONS MUST BE REFERRED TO THE IBM PURCHASING DEPARTMENT.					IBM CONFIDENTIAL

93P4047

	DATE	EC NO.	PART NO.	
	06/12/03	J18444	93P4047	
			DEVELOPMENT NO.	Q/M
				27 /83

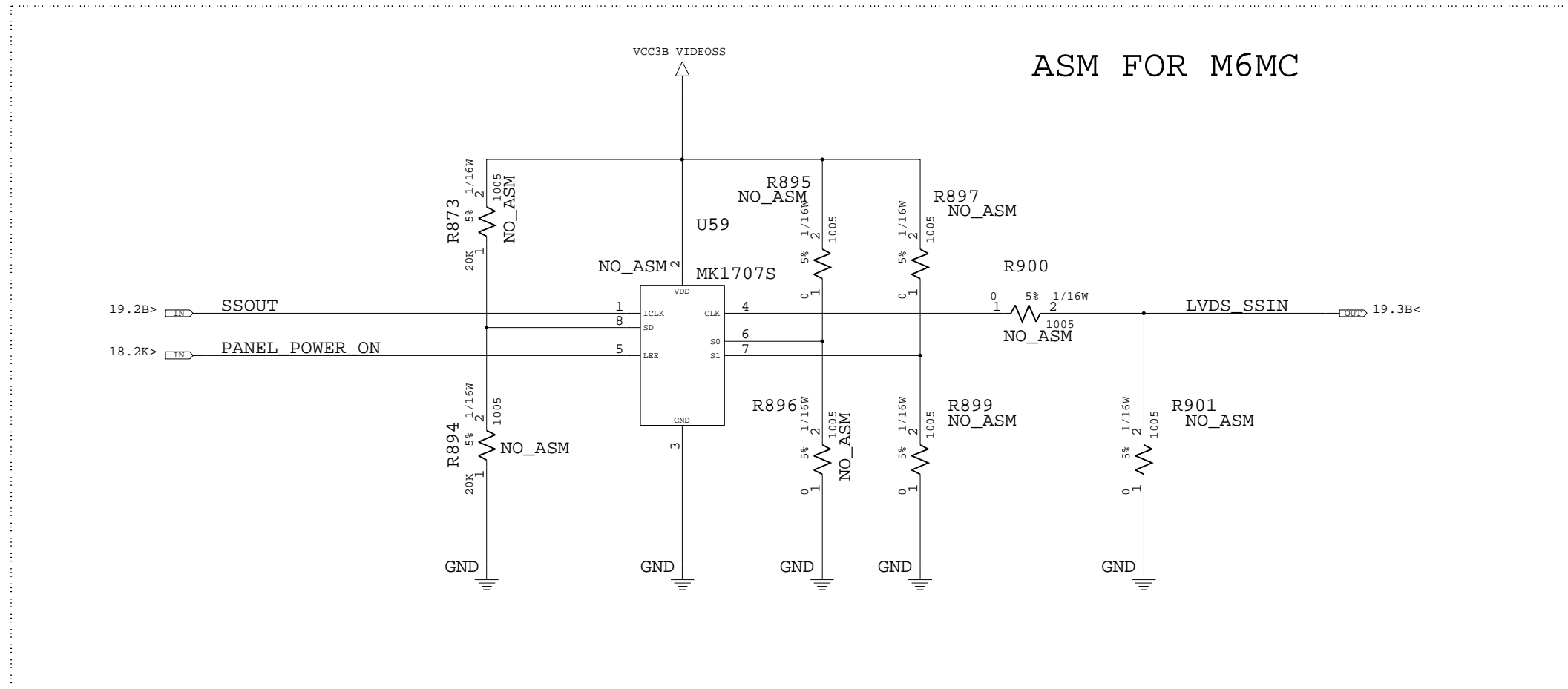

ASM FOR M6MC

93P4047

DESIGNER	Y.Y	06/12/03	PART NO.	93P4047	
CHECKED	Y.I	06/12/03	TITLE		
APPROVED	K.T	06/12/03	CLASS	GFX:RESERVE	
THIS DOCUMENT IS THE PROPERTY OF IBM ITS USE IS AUTHORIZED ONLY FOR RESPONDING TO A REQUEST FOR QUOTATION OR FOR THE PERFORMANCE OF WORK FOR IBM. ALL QUESTIONS MUST BE REFERRED TO THE IBM PURCHASING DEPARTMENT.					IBM CONFIDENTIAL

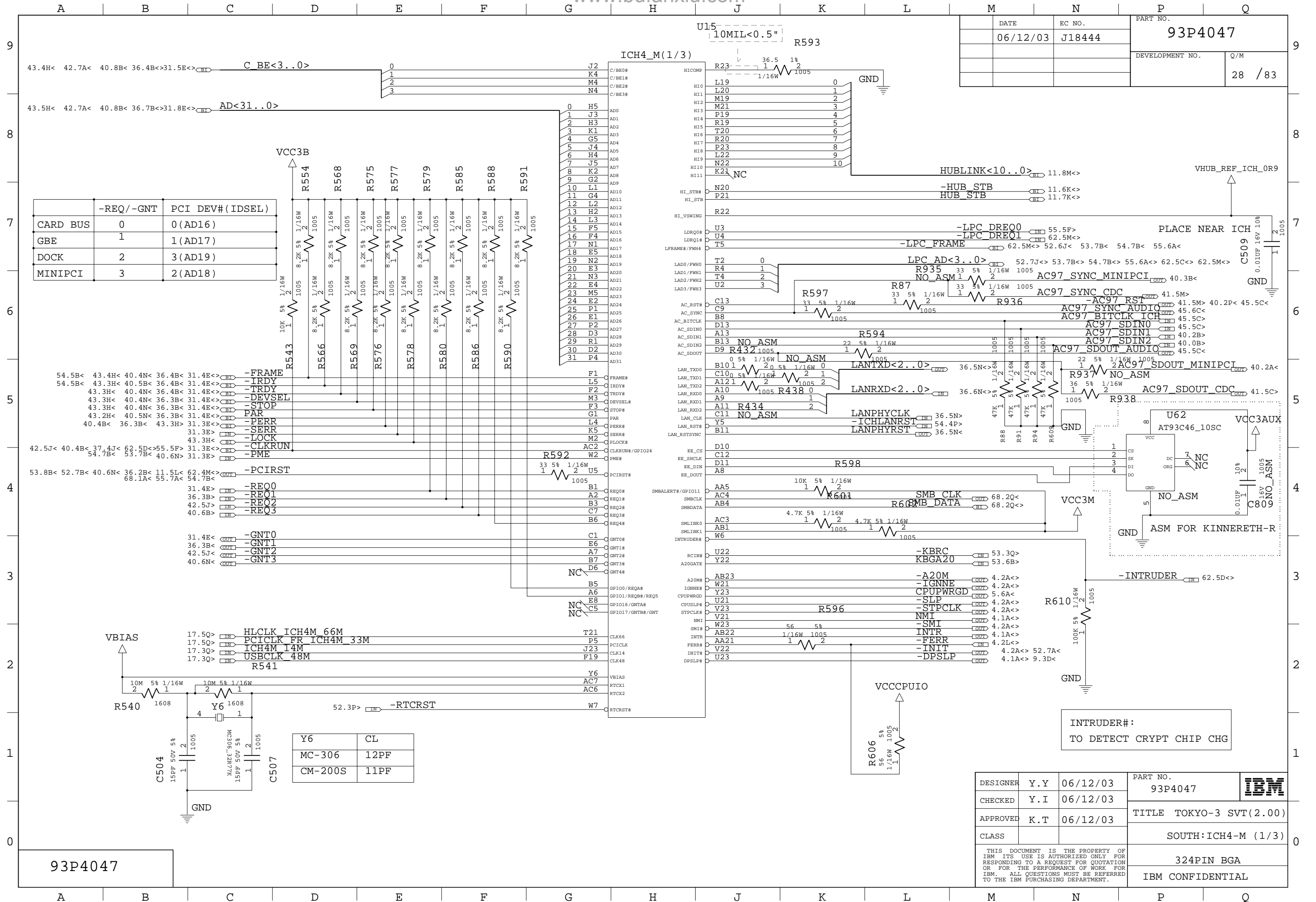

DATE	EC NO.	PART NO.
06/12/03	J18444	93P4047
DEVELOPMENT NO.		Q/M
		28 / 83

DESIGNER	Y.Y	06/12/03	PART NO.	93P4047	IBM
CHECKED	Y.I	06/12/03	TITLE TOKYO-3 SVT(2.00)		
APPROVED	K.T	06/12/03	SOUTH: ICH4-M (1/3)		
CLASS			324PIN BGA		
THIS DOCUMENT IS THE PROPERTY OF IBM ITS USE IS AUTHORIZED ONLY FOR RESPONDING TO A REQUEST FOR QUOTATION OR FOR THE PERFORMANCE OF WORK FOR IBM. ALL QUESTIONS MUST BE REFERRED TO THE IBM PURCHASING DEPARTMENT.					IBM CONFIDENTIAL

93P4047

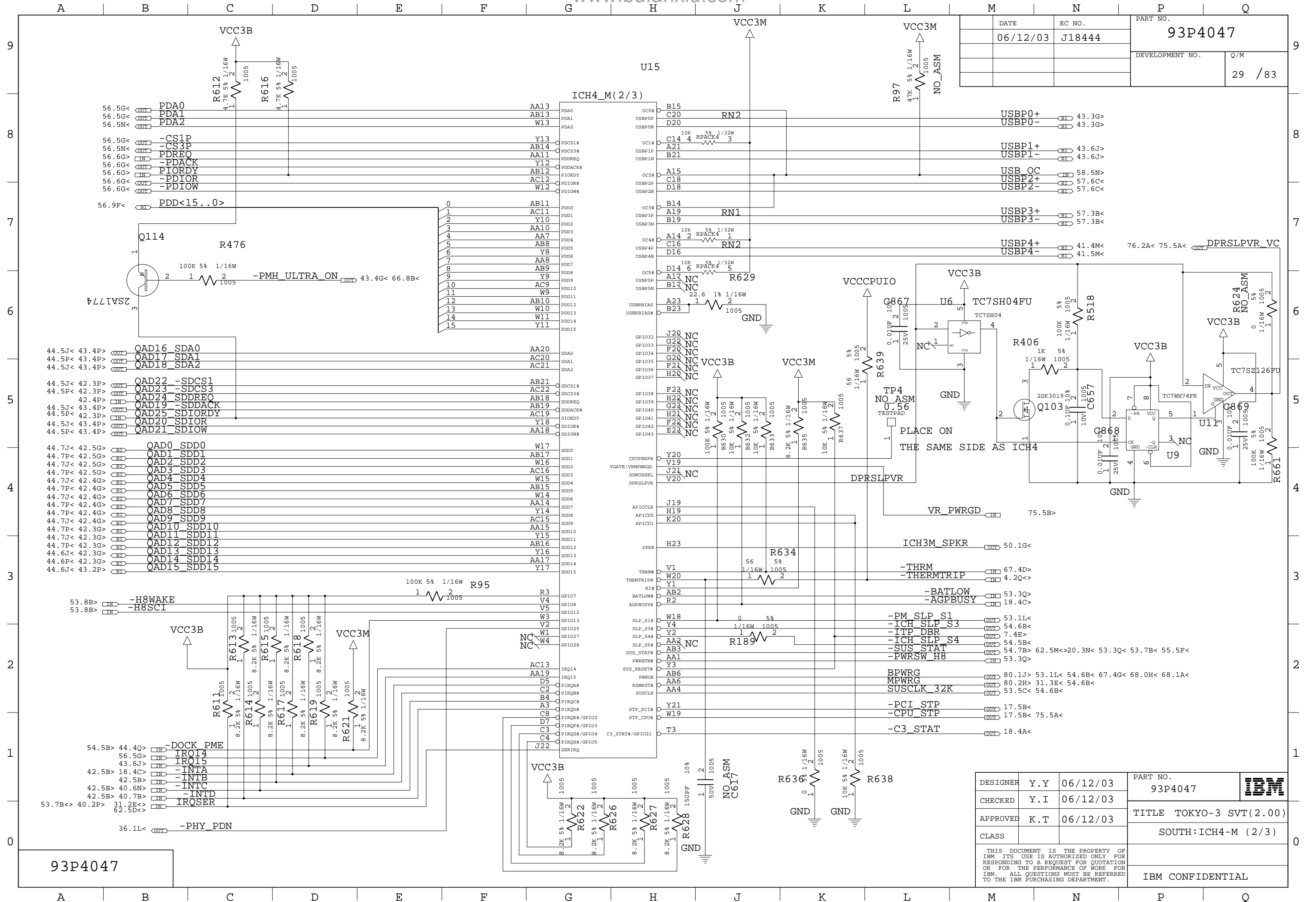

DATE	EC NO.	PART NO.
06/12/03	J18444	93P4047
DEVELOPMENT NO.		Q/M
		29 / 83

DESIGNER	Y.Y	06/12/03	PART NO.	93P4047	
CHECKED	Y.I	06/12/03	TITLE TOKYO-3 SVT(2.00)		
APPROVED	K.T	06/12/03	SOUTH: ICH4-M (2/3)		
CLASS			IBM CONFIDENTIAL		

THIS DOCUMENT IS THE PROPERTY OF IBM ITS USE IS AUTHORIZED ONLY FOR RESPONDING TO A REQUEST FOR QUOTATION OR FOR THE PERFORMANCE OF WORK FOR IBM. ALL QUESTIONS MUST BE REFERRED TO THE IBM PURCHASING DEPARTMENT.

93P4047

DATE	EC NO.	PART NO.
06/12/03	J18444	93P4047
DEVELOPMENT NO.		Q/M
		31 / 83

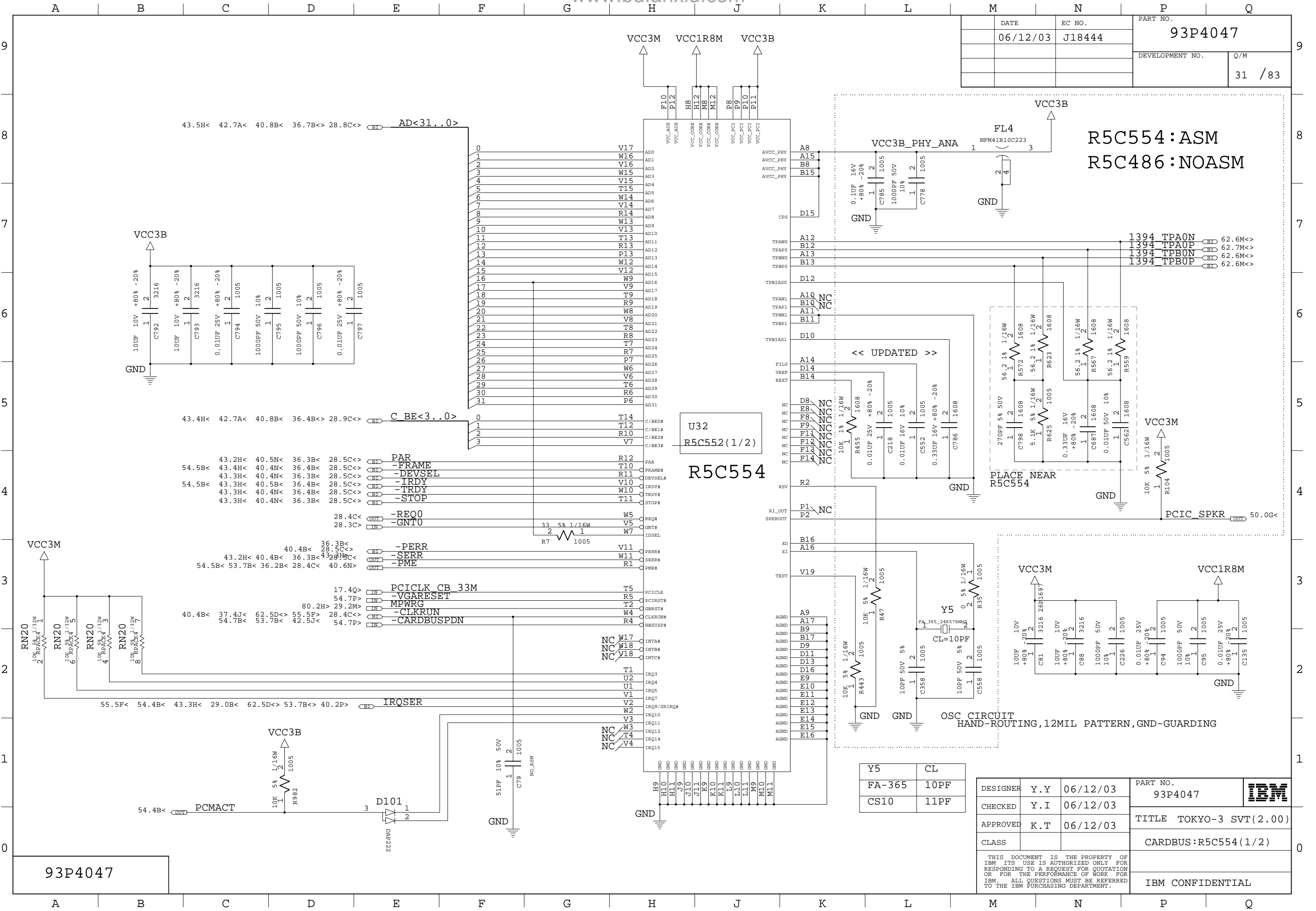

R5C554:ASM
R5C486:NOASM

U32
R5C552 (1/2)
R5C554

PLACE NEAR
R5C554

OSC CIRCUIT
HAND-ROUTING, 12MIL PATTERN, GND-GUARDING

Y5	CL
FA-365	10PF
CS10	11PF

DESIGNER	Y.Y	06/12/03	PART NO.	93P4047	IBM
CHECKED	Y.I	06/12/03	TITLE TOKYO-3 SVT(2.00)		
APPROVED	K.T	06/12/03	CARDBUS:R5C554(1/2)		
CLASS					

THIS DOCUMENT IS THE PROPERTY OF IBM ITS USE IS AUTHORIZED ONLY FOR RESPONDING TO A REQUEST FOR QUOTATION OR FOR THE PERFORMANCE OF WORK FOR IBM. ALL QUESTIONS MUST BE REFERRED TO THE IBM PURCHASING DEPARTMENT.

IBM CONFIDENTIAL

93P4047

DATE	EC NO.	PART NO.
06/12/03	J18444	93P4047
DEVELOPMENT NO.		Q/M
		32 / 83

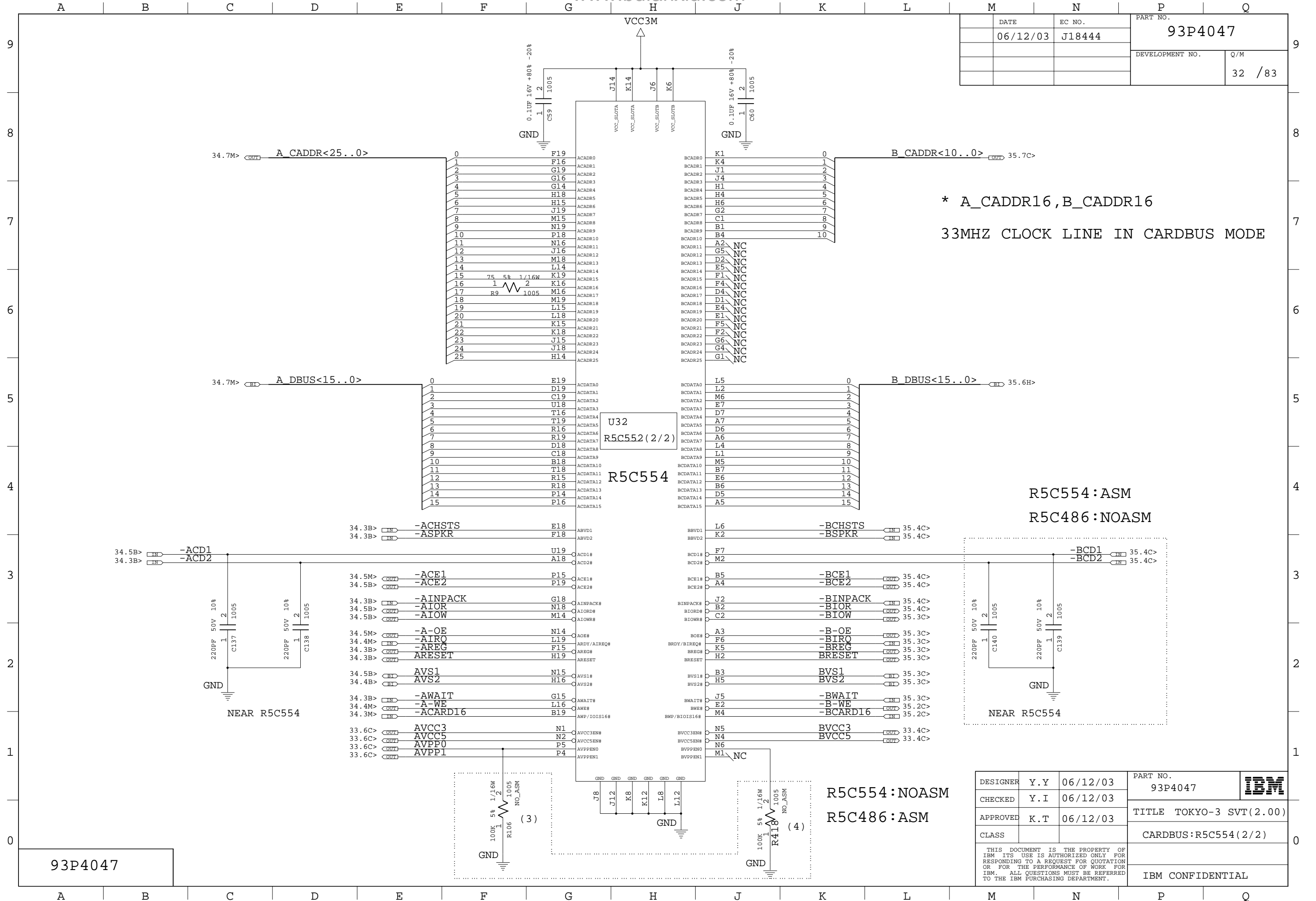

* A_CADDR16, B_CADDR16
33MHZ CLOCK LINE IN CARDBUS MODE

R5C554 : ASM
R5C486 : NOASM

NEAR R5C554

R5C554 : NOASM
R5C486 : ASM

93P4047

DESIGNER	Y.Y	06/12/03	PART NO.	93P4047	IBM
CHECKED	Y.I	06/12/03	TITLE TOKYO-3 SVT(2.00)		
APPROVED	K.T	06/12/03	CARDBUS:R5C554(2/2)		
CLASS			IBM CONFIDENTIAL		

THIS DOCUMENT IS THE PROPERTY OF IBM ITS USE IS AUTHORIZED ONLY FOR RESPONDING TO A REQUEST FOR QUOTATION OR FOR THE PERFORMANCE OF WORK FOR IBM. ALL QUESTIONS MUST BE REFERRED TO THE IBM PURCHASING DEPARTMENT.

DATE	EC NO.	PART NO.	
06/12/03	J18444	93P4047	
		DEVELOPMENT NO.	Q/M
			33 / 83

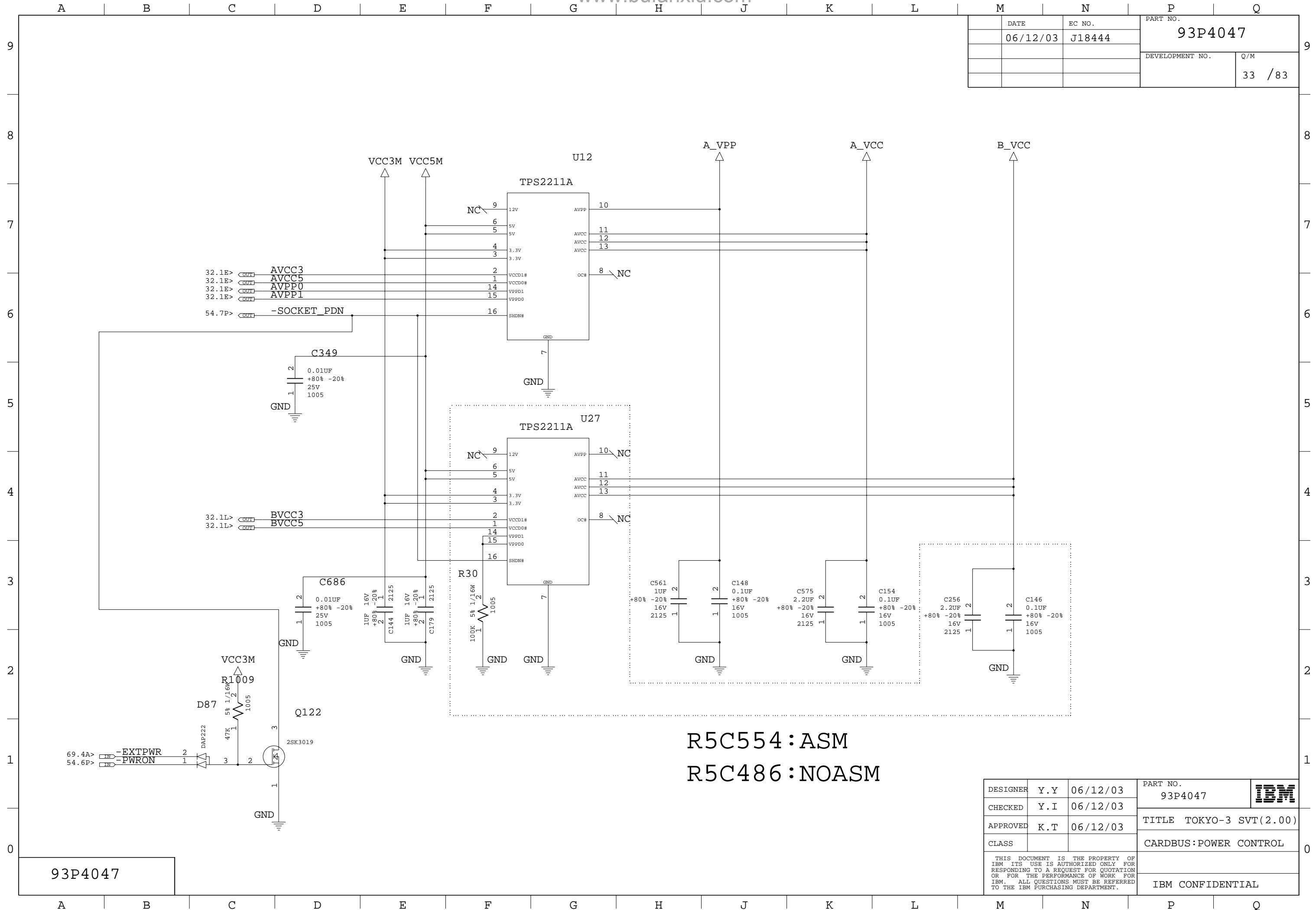

R5C554:ASM
R5C486:NOASM

93P4047

DESIGNER	Y.Y	06/12/03	PART NO.	93P4047	
CHECKED	Y.I	06/12/03	TITLE TOKYO-3 SVT(2.00)		
APPROVED	K.T	06/12/03	CLASS		CARDBUS:POWER CONTROL
THIS DOCUMENT IS THE PROPERTY OF IBM ITS USE IS AUTHORIZED ONLY FOR RESPONDING TO A REQUEST FOR QUOTATION OR FOR THE PERFORMANCE OF WORK FOR IBM. ALL QUESTIONS MUST BE REFERRED TO THE IBM PURCHASING DEPARTMENT.					IBM CONFIDENTIAL

DATE	EC NO.	PART NO.	
06/12/03	J18444	93P4047	
		DEVELOPMENT NO.	Q/M
			34 / 83

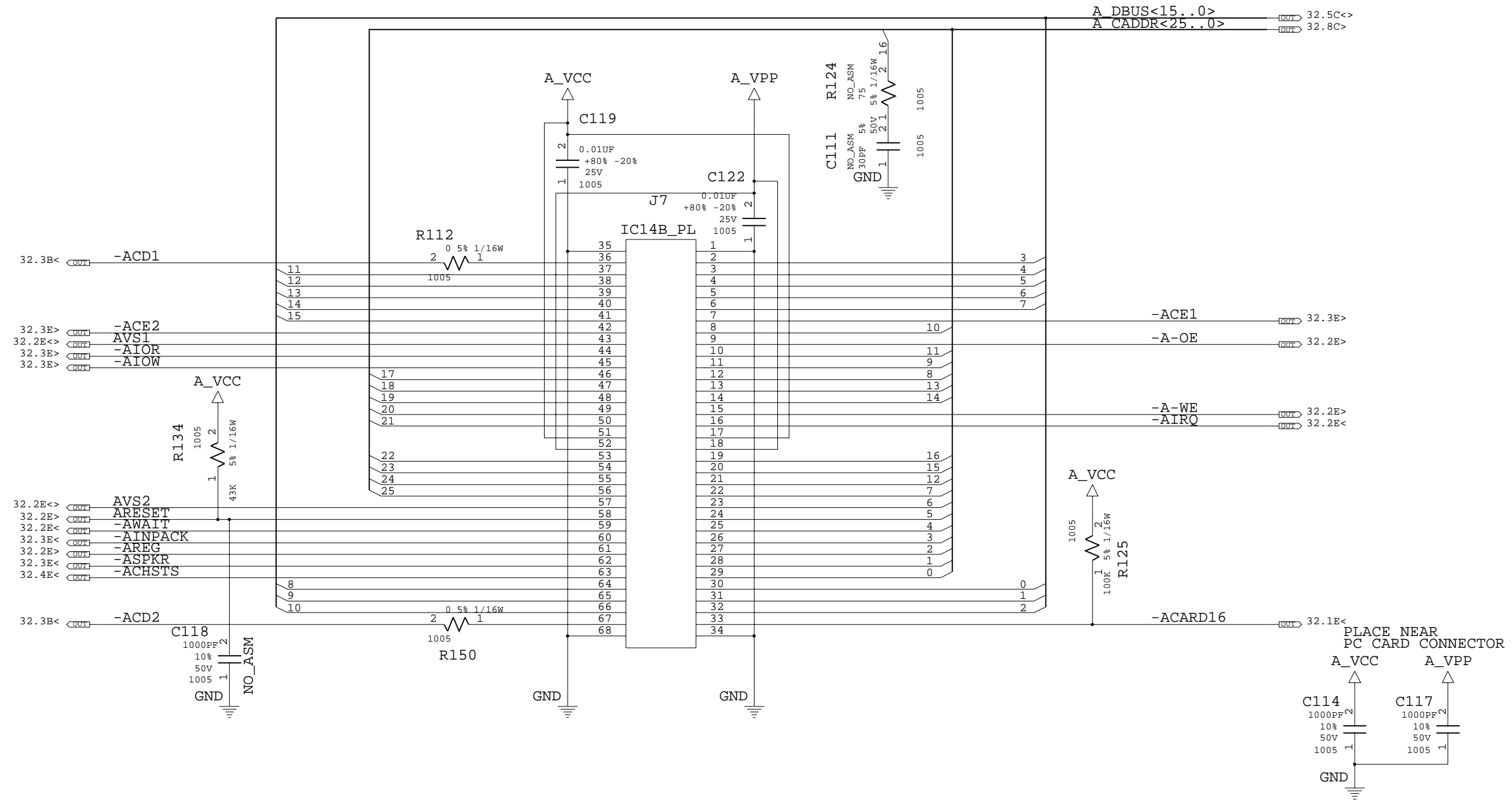

PLACE NEAR PC CARD CONNECTOR

93P4047

DESIGNER	Y.Y	06/12/03	PART NO.	93P4047	IBM
CHECKED	Y.I	06/12/03	TITLE TOKYO-3 SVT(2.00)		
APPROVED	K.T	06/12/03	CLASS		CARDBUS:PCMCIA SLOT
THIS DOCUMENT IS THE PROPERTY OF IBM ITS USE IS AUTHORIZED ONLY FOR RESPONDING TO A REQUEST FOR QUOTATION OR FOR THE PERFORMANCE OF WORK FOR IBM. ALL QUESTIONS MUST BE REFERRED TO THE IBM PURCHASING DEPARTMENT.					IBM CONFIDENTIAL

DATE	EC NO.	PART NO.	
06/12/03	J18444	93P4047	
		DEVELOPMENT NO.	Q/M
			35 / 83

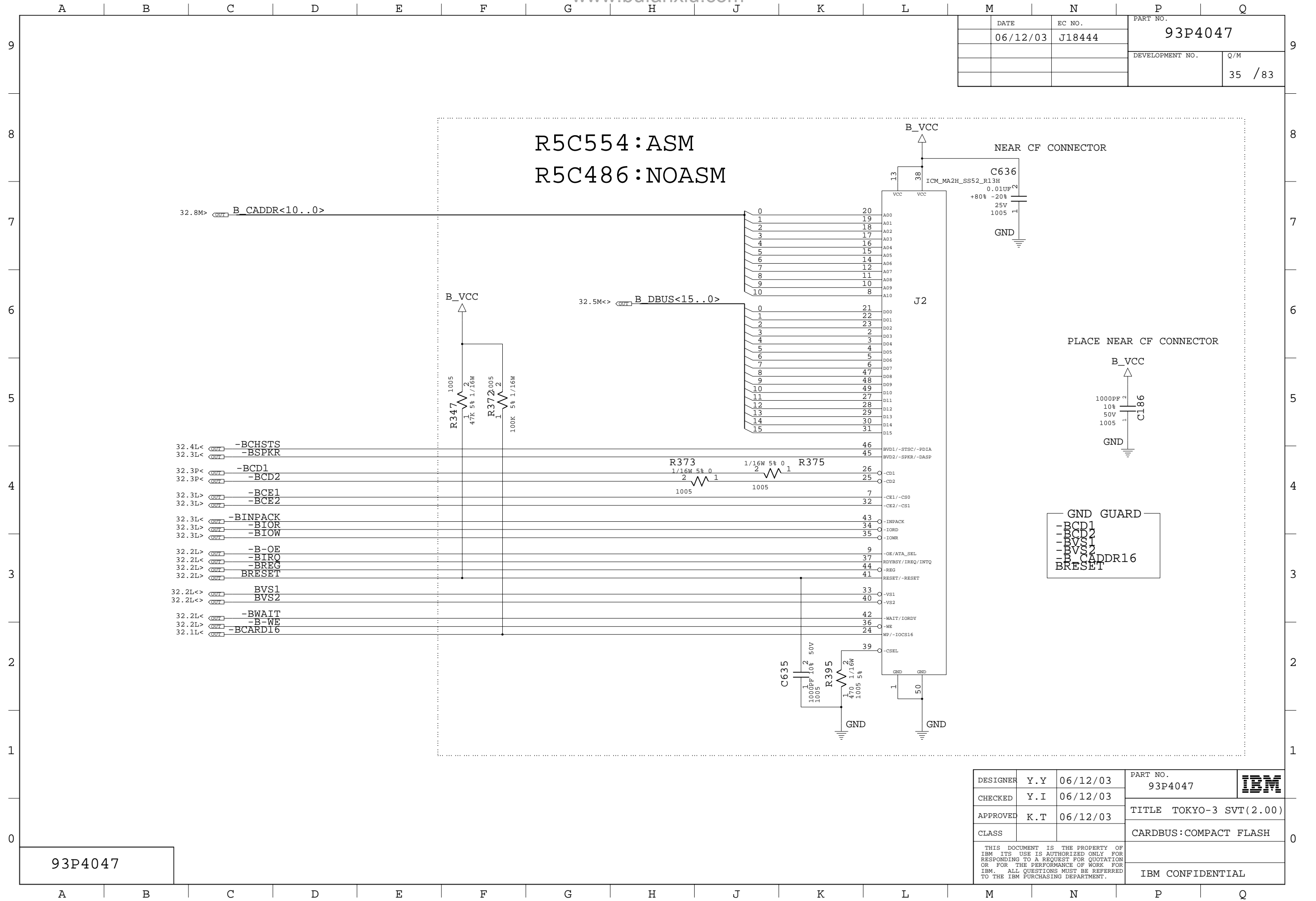

93P4047

DESIGNER	Y.Y	06/12/03	PART NO.	93P4047	IBM
CHECKED	Y.I	06/12/03	TITLE TOKYO-3 SVT(2.00)		
APPROVED	K.T	06/12/03	CLASS		
			CARDBUS:COMPACT FLASH		
THIS DOCUMENT IS THE PROPERTY OF IBM ITS USE IS AUTHORIZED ONLY FOR RESPONDING TO A REQUEST FOR QUOTATION OR FOR THE PERFORMANCE OF WORK FOR IBM. ALL QUESTIONS MUST BE REFERRED TO THE IBM PURCHASING DEPARTMENT.					IBM CONFIDENTIAL

DATE	EC NO.	PART NO.
06/12/03	J18444	93P4047
DEVELOPMENT NO.		Q/M
		36 / 83

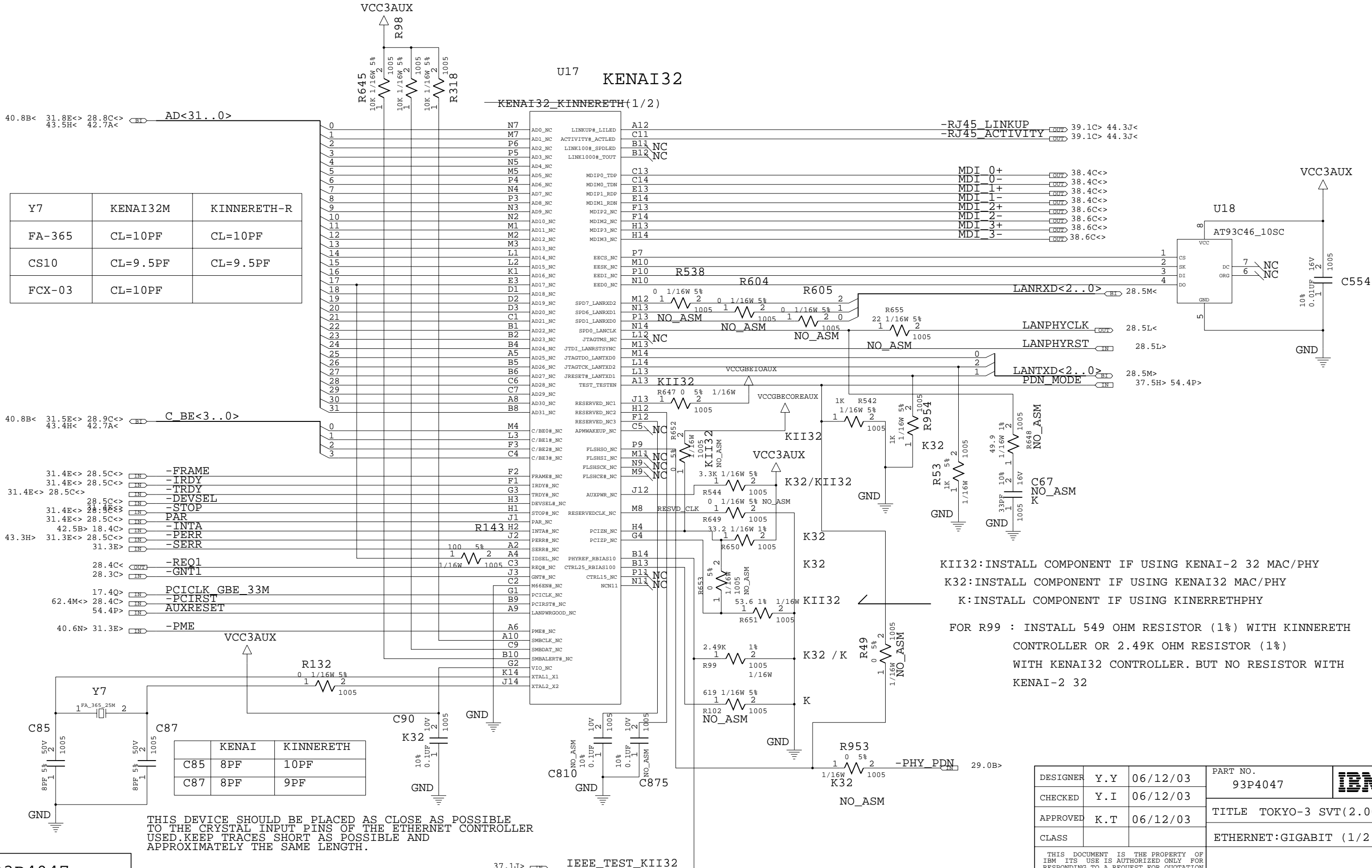

Y7	KENAI32M	KINNERETH-R
FA-365	CL=10PF	CL=10PF
CS10	CL=9.5PF	CL=9.5PF
FCX-03	CL=10PF	

40.8B<	31.5E<>	28.9C<>	C BE<3..0>
43.5H<	42.7A<		

31.4E<>	28.5C<>	-FRAME
31.4E<>	28.5C<>	-IRDY
31.4E<>	28.5C<>	-TRDY
31.4E<>	28.5C<>	-DEVSEL
31.4E<>	28.5C<>	-STOP
31.4E<>	28.5C<>	PAR
42.5B>	18.4C>	-INTA
31.3E<>	28.5C<>	-PERR
31.3E>	31.3E>	-SERR

28.4C<	-REQ1
28.3C<	-GNT1
17.4Q>	PCICLK_GBE_33M
62.4M<>	-PCIRST
54.4P>	AUXRESET

40.6N>	31.3E>	-PME
--------	--------	------

	KENAI	KINNERETH
C85	8PF	10PF
C87	8PF	9PF

THIS DEVICE SHOULD BE PLACED AS CLOSE AS POSSIBLE TO THE CRYSTAL INPUT PINS OF THE ETHERNET CONTROLLER USED. KEEP TRACES SHORT AS POSSIBLE AND APPROXIMATELY THE SAME LENGTH.

KII32: INSTALL COMPONENT IF USING KENAI-2 32 MAC/PHY
 K32: INSTALL COMPONENT IF USING KENAI32 MAC/PHY
 K: INSTALL COMPONENT IF USING KINNERETHPHY
 FOR R99 : INSTALL 549 OHM RESISTOR (1%) WITH KINNERETH CONTROLLER OR 2.49K OHM RESISTOR (1%) WITH KENAI32 CONTROLLER. BUT NO RESISTOR WITH KENAI-2 32

DESIGNER	Y.Y	06/12/03	PART NO.	93P4047	IBM
CHECKED	Y.I	06/12/03			
APPROVED	K.T	06/12/03	TITLE TOKYO-3 SVT(2.00)		
CLASS			ETHERNET:GIGABIT (1/2)		
THIS DOCUMENT IS THE PROPERTY OF IBM ITS USE IS AUTHORIZED ONLY FOR RESPONDING TO A REQUEST FOR QUOTATION OR FOR THE PERFORMANCE OF WORK FOR IBM. ALL QUESTIONS MUST BE REFERRED TO THE IBM PURCHASING DEPARTMENT.					IBM CONFIDENTIAL

93P4047

37.1J> IEEE TEST KII32

DATE	EC NO.	PART NO.	
06/12/03	J18444	93P4047	
DEVELOPMENT NO.		Q/M	
		37 / 83	

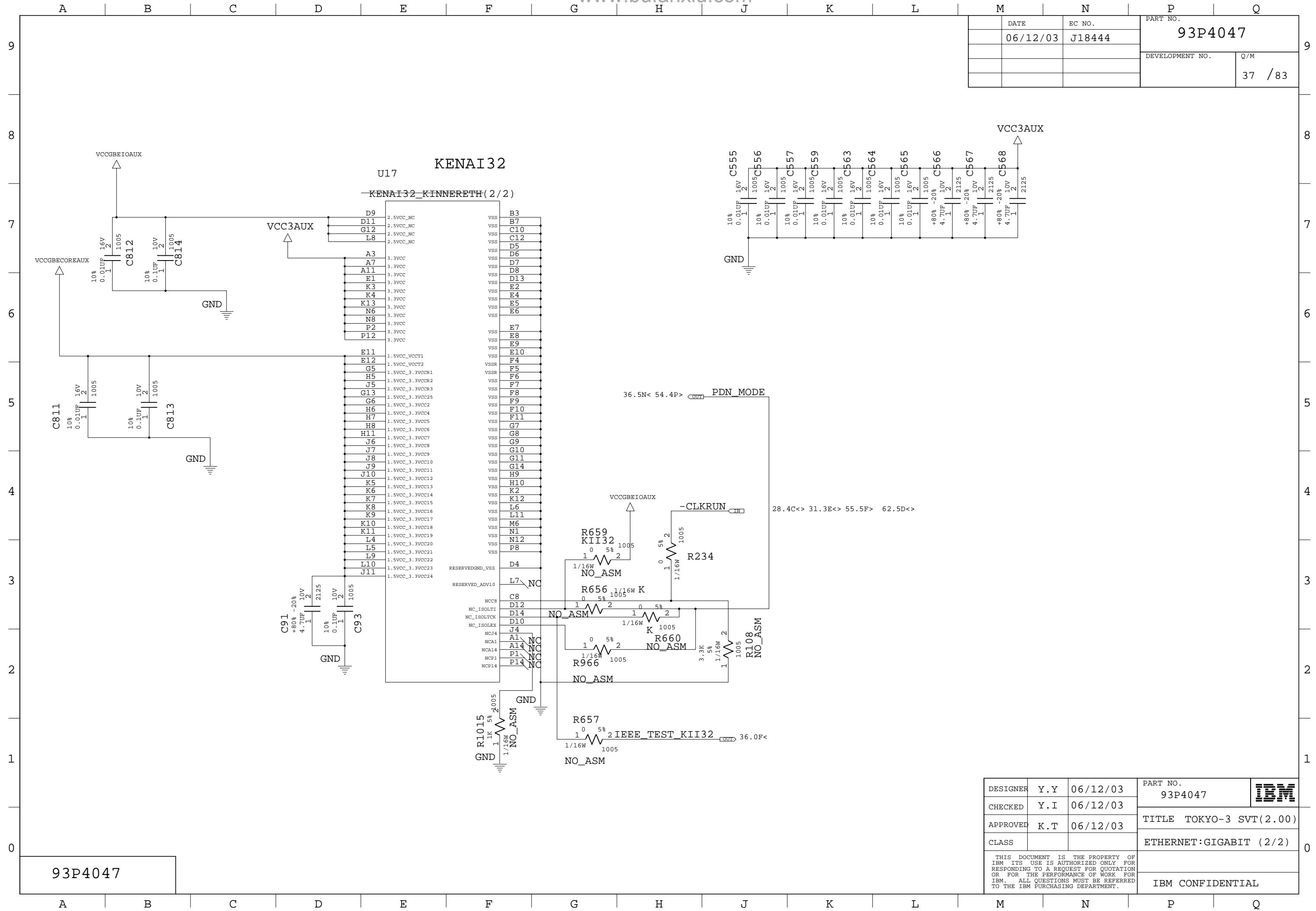

93P4047

DESIGNER	Y.Y	06/12/03	PART NO.	93P4047	IBM
CHECKED	Y.I	06/12/03	TITLE TOKYO-3 SVT(2.00)		
APPROVED	K.T	06/12/03	ETHERNET:GIGABIT (2/2)		
CLASS					
THIS DOCUMENT IS THE PROPERTY OF IBM ITS USE IS AUTHORIZED ONLY FOR RESPONDING TO A REQUEST FOR QUOTATION OR FOR THE PERFORMANCE OF WORK FOR IBM. ALL QUESTIONS MUST BE REFERRED TO THE IBM PURCHASING DEPARTMENT.					IBM CONFIDENTIAL

DATE	06/12/03	EC NO.	J18444	PART NO.	93P4047
DEVELOPMENT NO.		Q/M	38 / 83		

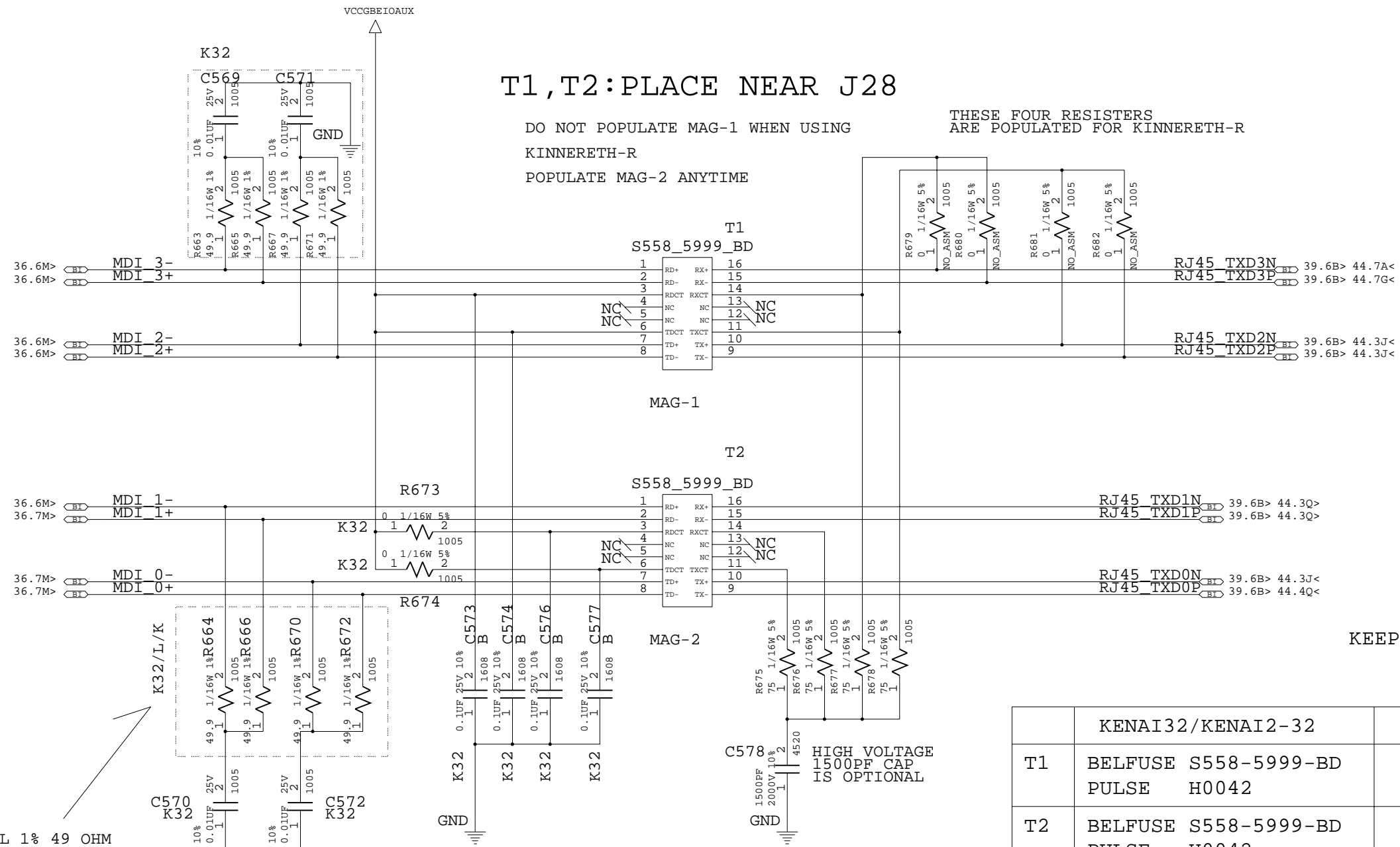

INSTALL 1% 49 OHM RESISTORS WITH KENAI32 AND WITH KENAI-2 32, OR 1% 60.4 OHM RESISTORS WITH LAVON AND KINNERETH-R CONTROLLERS.

	KENAI32/KENAI2-32	KINNERETH-R
T1	BELFUSE S558-5999-BD PULSE H0042	NOASM
T2	BELFUSE S558-5999-BD PULSE H0042	BELFUSE S558-5999-U1 PULSE H0042

93P4047

DESIGNER	Y.Y	06/12/03	PART NO.	93P4047	
CHECKED	Y.I	06/12/03	TITLE TOKYO-3 SVT(2.00)		
APPROVED	K.T	06/12/03	ETHERNET:MAGNETICS		
CLASS			THIS DOCUMENT IS THE PROPERTY OF IBM ITS USE IS AUTHORIZED ONLY FOR RESPONDING TO A REQUEST FOR QUOTATION OR FOR THE PERFORMANCE OF WORK FOR IBM. ALL QUESTIONS MUST BE REFERRED TO THE IBM PURCHASING DEPARTMENT.		IBM CONFIDENTIAL

DATE	EC NO.	PART NO.	
06/12/03	J18444	93P4047	
		DEVELOPMENT NO.	Q/M
			39 / 83

KEEP AWAY FROM OTHER TRACES

- 44.4Q< 38.4M<> RJ45 TXD0P
- 44.3J< 38.4M<> RJ45 TXDON
- 44.3Q> 38.4M<> RJ45 TXD1P
- 44.3J< 38.6M<> RJ45 TXD2P
- 44.3J< 38.6M<> RJ45 TXD2N
- 44.3Q> 38.4M<> RJ45 TXD1N
- 44.7G< 38.6M<> RJ45 TXD3P
- 44.7A< 38.6M<> RJ45 TXD3N

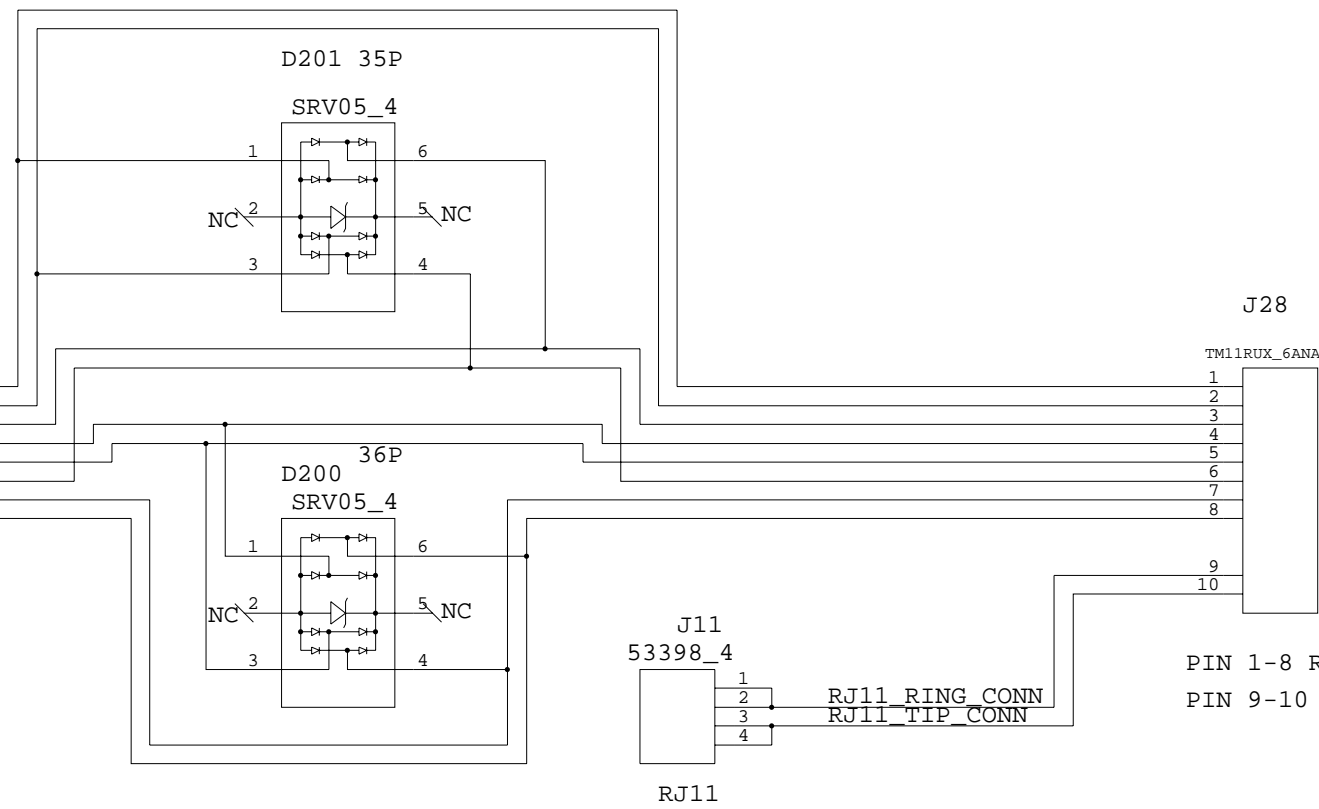

PIN 1-8 RJ45 PINS
PIN 9-10 RJ11 PINS

RJ11 RING CONN
RJ11 TIP CONN

DISTANCE FROM
RJ45TERM AND GND
PLANE SHOULD BE
FARHTER THAN 0.6MM

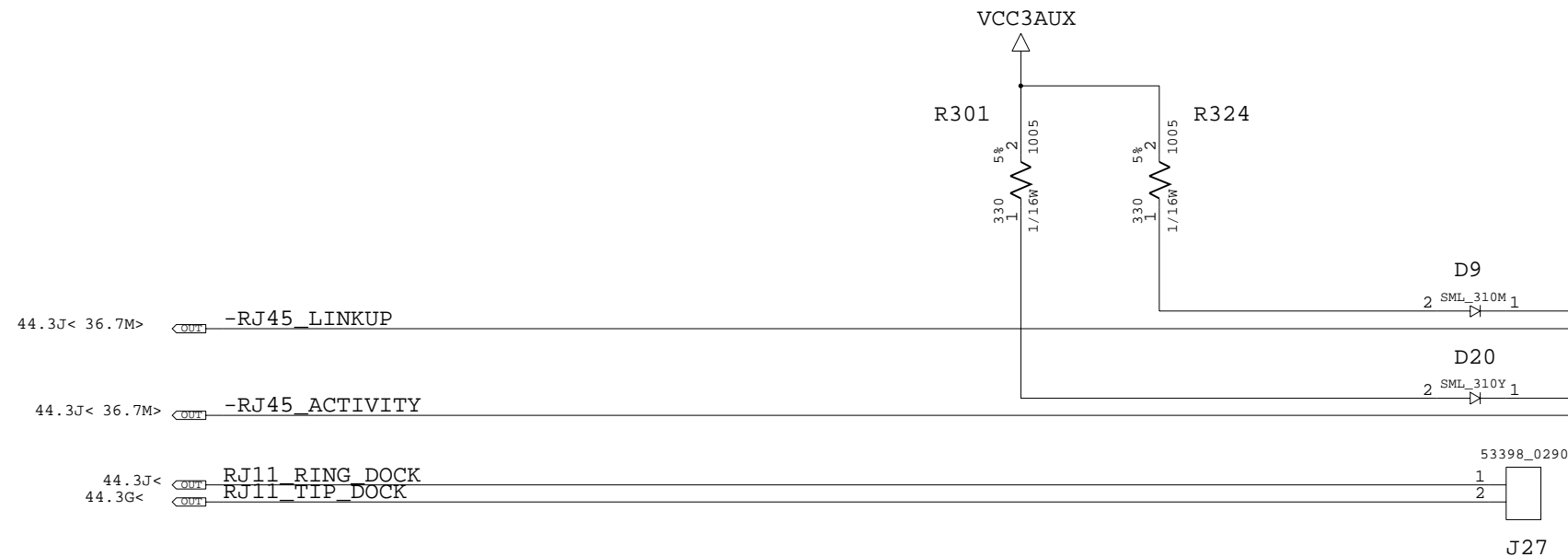

- 44.3J< 36.7M> -RJ45 LINKUP
- 44.3J< 36.7M> -RJ45 ACTIVITY
- 44.3J< RJ11 RING DOCK
- 44.3G< RJ11 TIP DOCK

93P4047

DESIGNER	Y.Y	06/12/03	PART NO.	93P4047	
CHECKED	Y.I	06/12/03			
APPROVED	K.T	06/12/03	TITLE TOKYO-3 SVT(2.00)		
CLASS			ETHERNET:RJ11/RJ45 CONNECTOR		
THIS DOCUMENT IS THE PROPERTY OF IBM ITS USE IS AUTHORIZED ONLY FOR RESPONDING TO A REQUEST FOR QUOTATION OR FOR THE PERFORMANCE OF WORK FOR IBM. ALL QUESTIONS MUST BE REFERRED TO THE IBM PURCHASING DEPARTMENT.					IBM CONFIDENTIAL

MINI PCI

DATE	EC NO.	PART NO.	
06/12/03	J18444	93P4047	
		DEVELOPMENT NO.	Q/M
			40 / 83

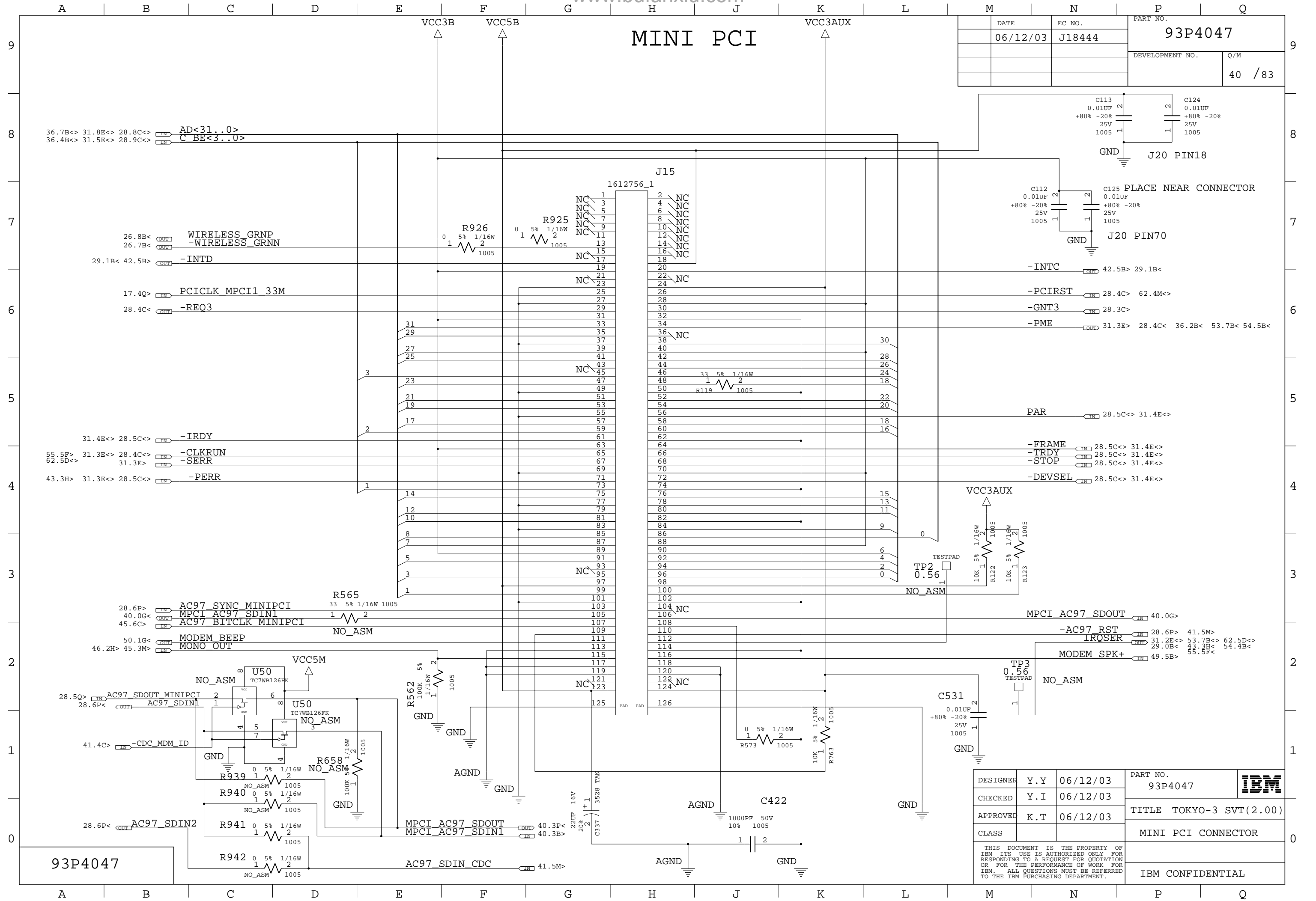

93P4047

DESIGNER	Y.Y	06/12/03	PART NO.	93P4047	
CHECKED	Y.I	06/12/03	TITLE TOKYO-3 SVT(2.00)		
APPROVED	K.T	06/12/03	MINI PCI CONNECTOR		
CLASS			IBM CONFIDENTIAL		

THIS DOCUMENT IS THE PROPERTY OF IBM ITS USE IS AUTHORIZED ONLY FOR RESPONDING TO A REQUEST FOR QUOTATION OR FOR THE PERFORMANCE OF WORK FOR IBM. ALL QUESTIONS MUST BE REFERRED TO THE IBM PURCHASING DEPARTMENT.

DATE	06/12/03	EC NO.	J18444	PART NO.	93P4047	
DEVELOPMENT NO.			41 / 83			

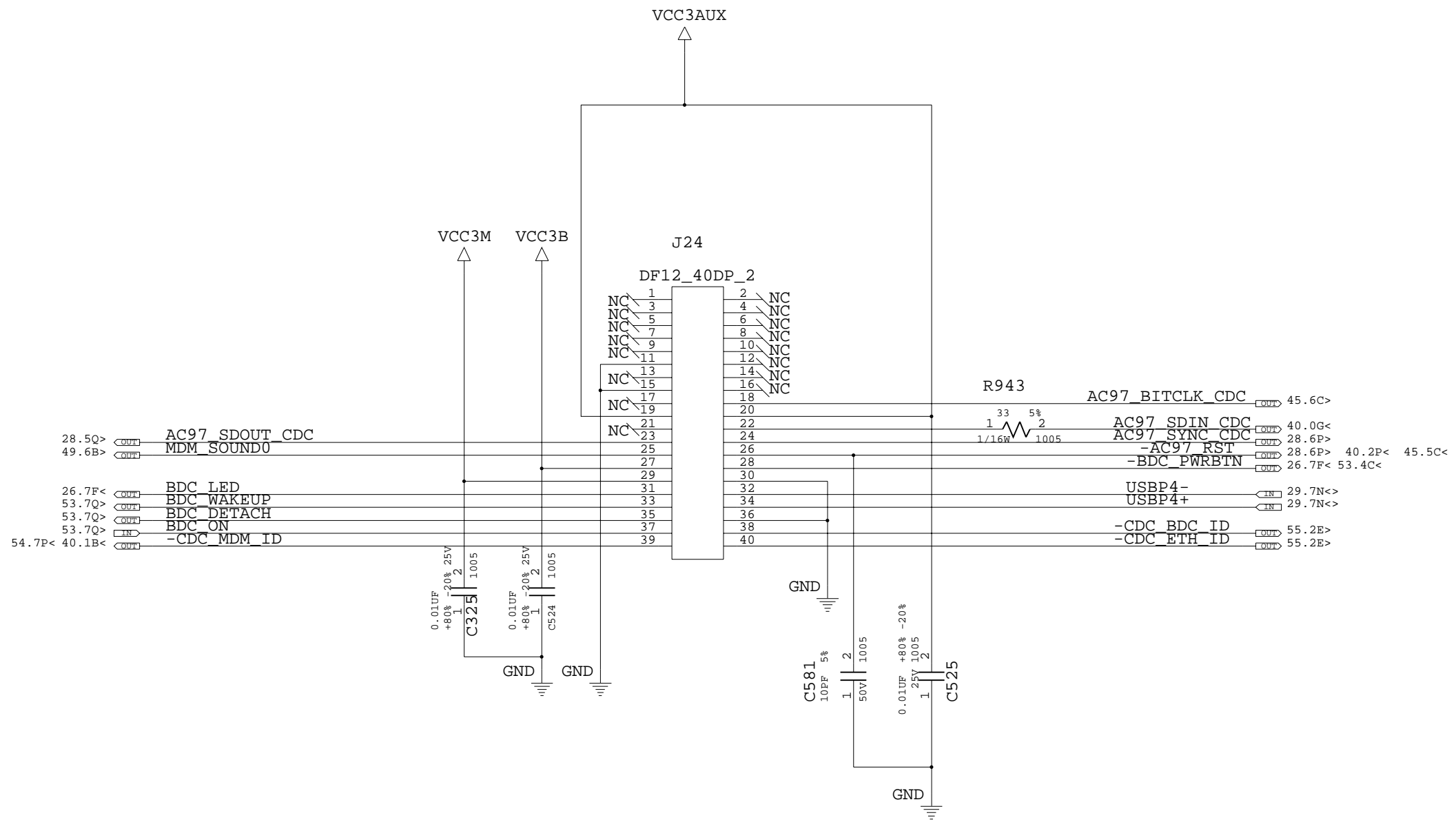

93P4047

DESIGNER	Y.Y	06/12/03	PART NO.	93P4047	IBM
CHECKED	Y.I	06/12/03	TITLE TOKYO-3 SVT(2.00)		
APPROVED	K.T	06/12/03	CLASS		CDC CONNECTOR(BMDC)
THIS DOCUMENT IS THE PROPERTY OF IBM ITS USE IS AUTHORIZED ONLY FOR RESPONDING TO A REQUEST FOR QUOTATION OR FOR THE PERFORMANCE OF WORK FOR IBM. ALL QUESTIONS MUST BE REFERRED TO THE IBM PURCHASING DEPARTMENT.					IBM CONFIDENTIAL

DATE	EC NO.	PART NO.	
06/12/03	J18444	93P4047	
		DEVELOPMENT NO.	Q/M
			42 / 83

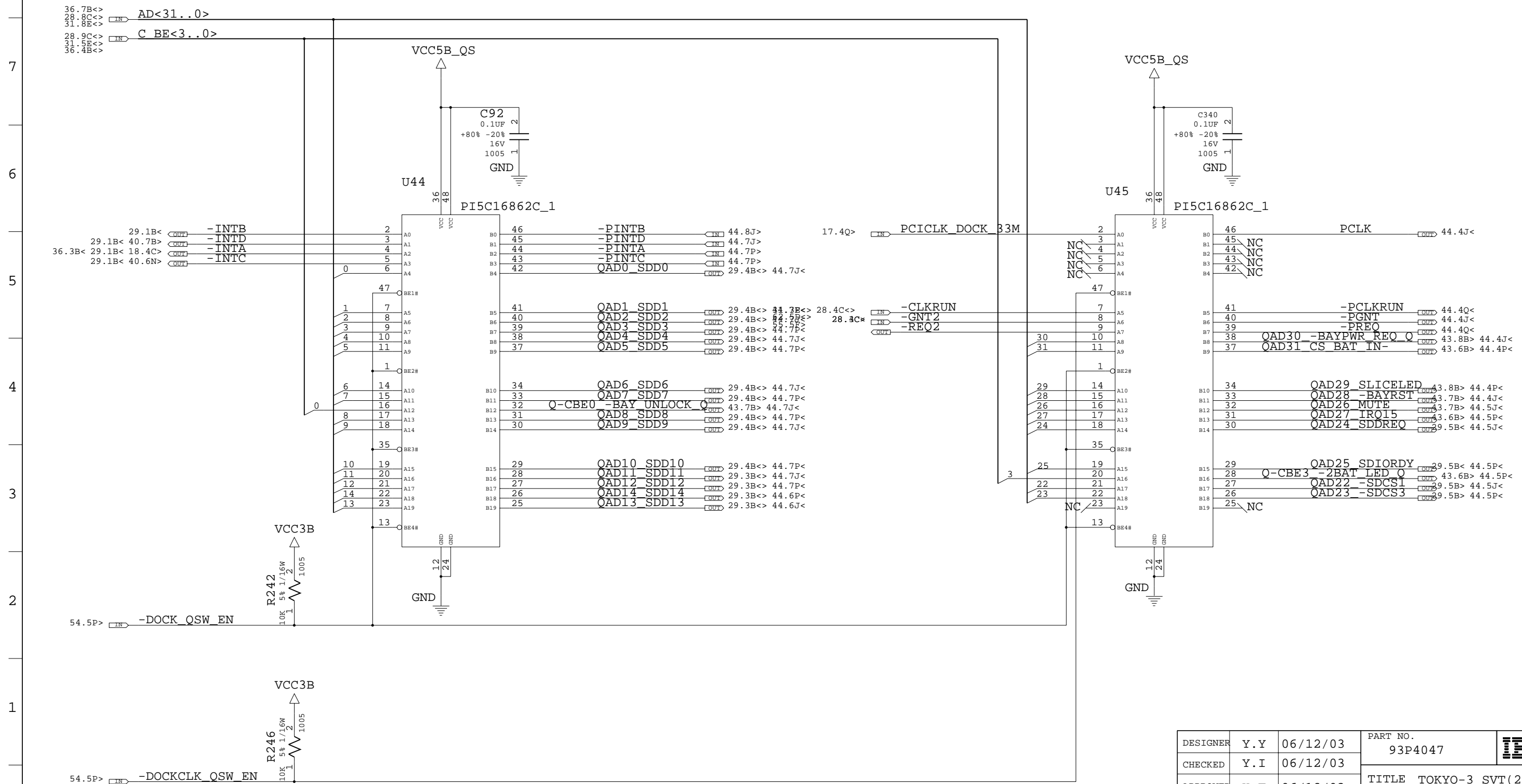

93P4047

DESIGNER	Y.Y	06/12/03	PART NO.	93P4047	IBM
CHECKED	Y.I	06/12/03	TITLE TOKYO-3 SVT(2.00)		
APPROVED	K.T	06/12/03	PCI BUS SWITCH(1/2)		
CLASS					
THIS DOCUMENT IS THE PROPERTY OF IBM ITS USE IS AUTHORIZED ONLY FOR RESPONDING TO A REQUEST FOR QUOTATION OR FOR THE PERFORMANCE OF WORK FOR IBM. ALL QUESTIONS MUST BE REFERRED TO THE IBM PURCHASING DEPARTMENT.					IBM CONFIDENTIAL

DATE	EC NO.	PART NO.	
06/12/03	J18444	93P4047	
		DEVELOPMENT NO.	Q/M
		43	/83

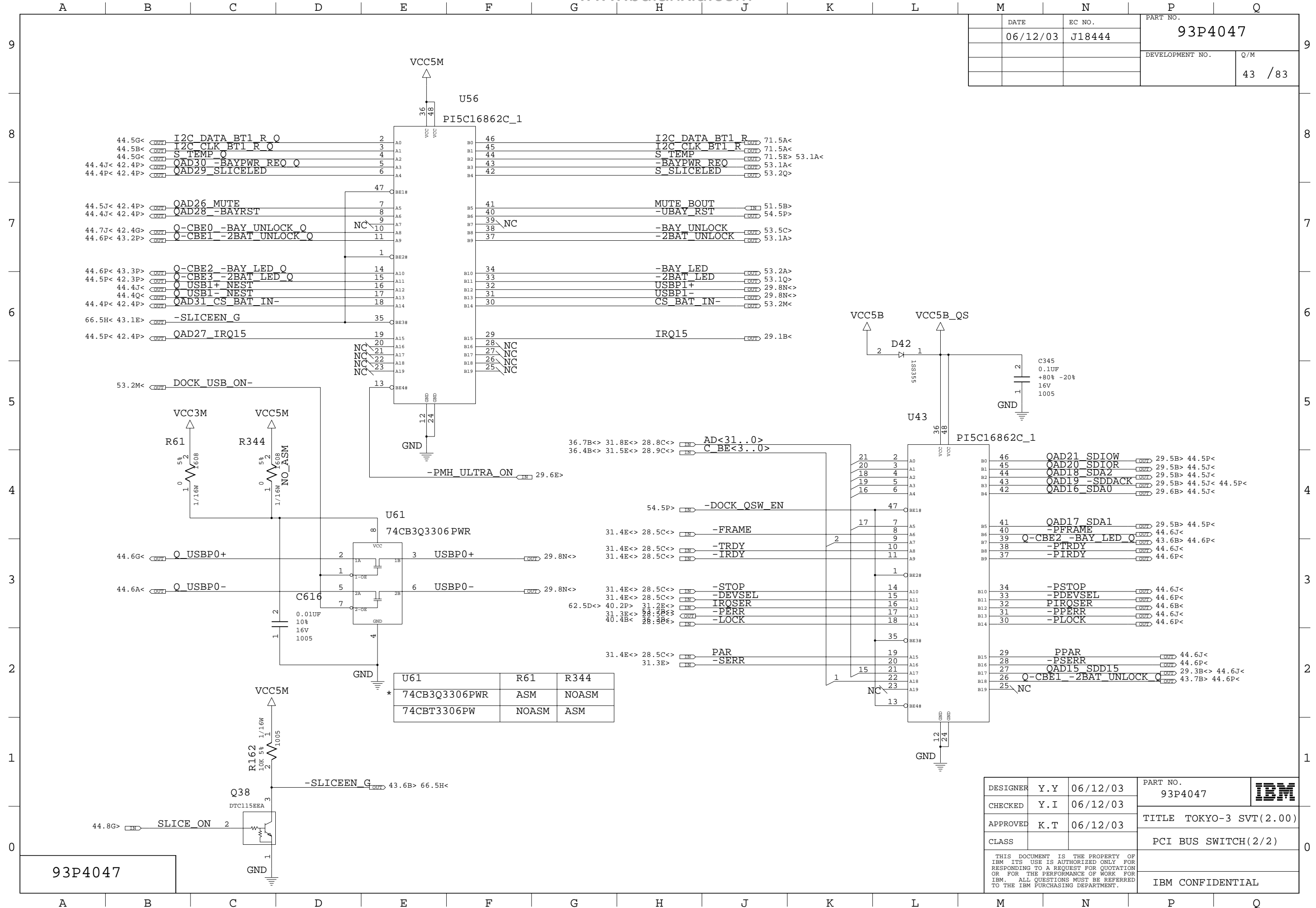

U61	R61	R344
74CB3Q3306PWR	ASM	NOASM
74CBT3306PW	NOASM	ASM

DESIGNER	Y.Y	06/12/03	PART NO.	93P4047	IBM
CHECKED	Y.I	06/12/03	TITLE TOKYO-3 SVT(2.00)		
APPROVED	K.T	06/12/03	CLASS		PCI BUS SWITCH(2/2)
THIS DOCUMENT IS THE PROPERTY OF IBM ITS USE IS AUTHORIZED ONLY FOR RESPONDING TO A REQUEST FOR QUOTATION OR FOR THE PERFORMANCE OF WORK FOR IBM. ALL QUESTIONS MUST BE REFERRED TO THE IBM PURCHASING DEPARTMENT.					IBM CONFIDENTIAL

93P4047

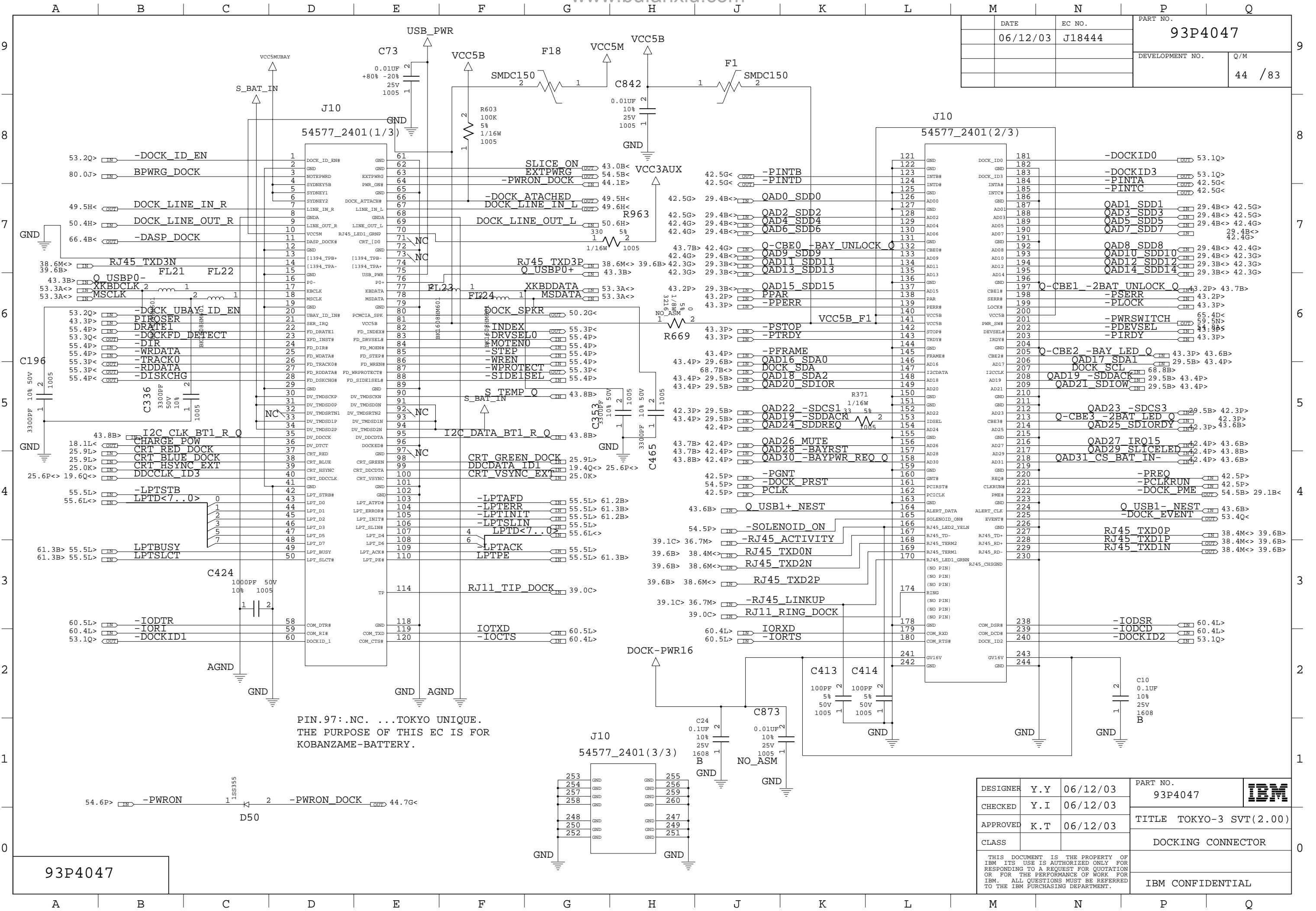

DATE	EC NO.	PART NO.
06/12/03	J18444	93P4047
DEVELOPMENT NO.		Q/M
		44 / 83

PIN.97: .NC. ...TOKYO UNIQUE.
 THE PURPOSE OF THIS EC IS FOR
 KOBANZAME-BATTERY.

DESIGNER	Y.Y	06/12/03	PART NO.	93P4047	IBM
CHECKED	Y.I	06/12/03	TITLE TOKYO-3 SVT(2.00)		
APPROVED	K.T	06/12/03	DOCKING CONNECTOR		
CLASS			DOCKING CONNECTOR		
THIS DOCUMENT IS THE PROPERTY OF IBM ITS USE IS AUTHORIZED ONLY FOR RESPONDING TO A REQUEST FOR QUOTATION OR FOR THE PERFORMANCE OF WORK FOR IBM. ALL QUESTIONS MUST BE REFERRED TO THE IBM PURCHASING DEPARTMENT.					IBM CONFIDENTIAL

93P4047

DATE	EC NO.	PART NO.
06/12/03	J18444	93P4047
DEVELOPMENT NO.		Q/M
		45 / 83

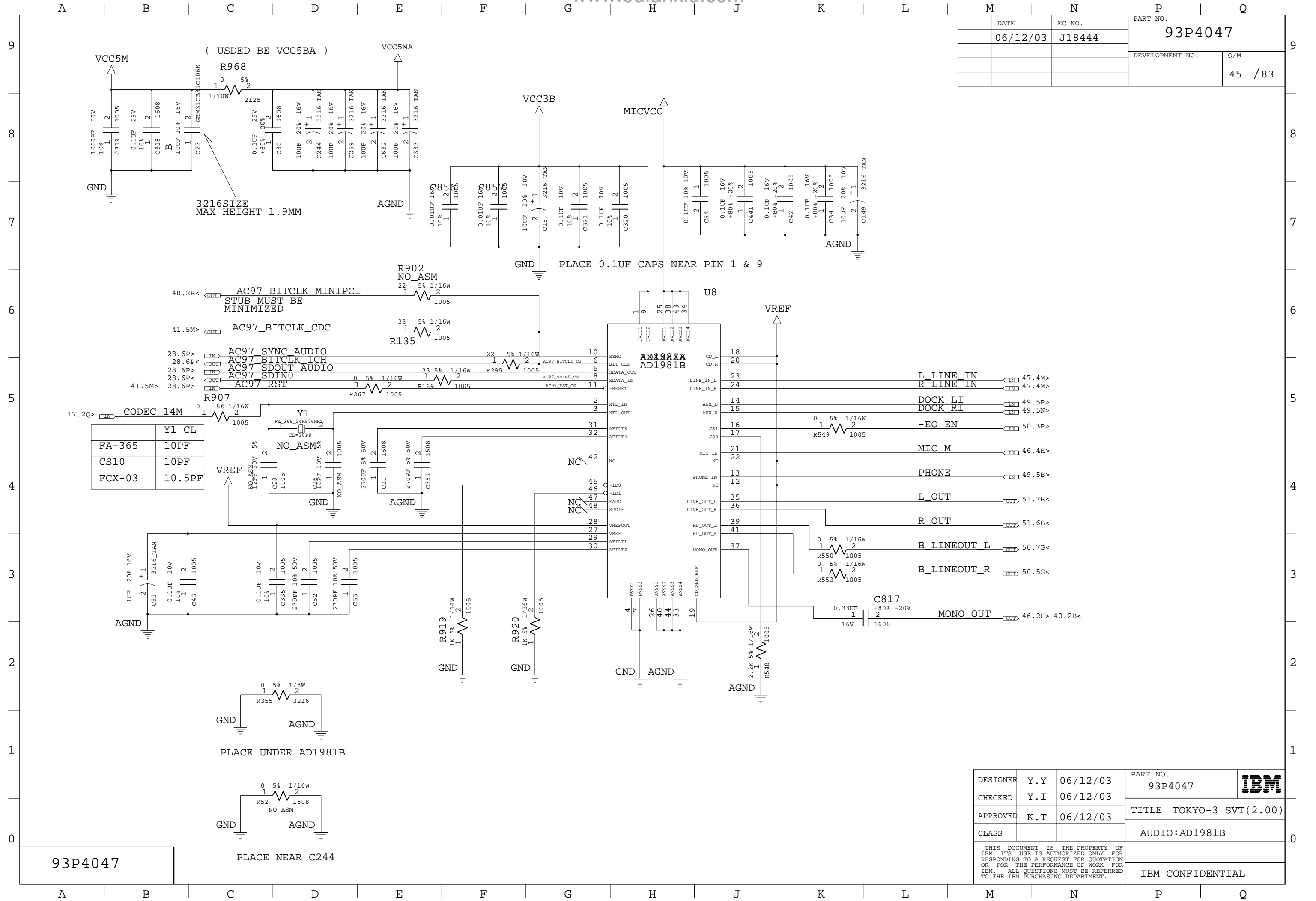

Y1 CL	
FA-365	10PF
CS10	10PF
FCX-03	10.5PF

DESIGNER	Y.Y	06/12/03	PART NO.	93P4047	IBM
CHECKED	Y.I	06/12/03	TITLE TOKYO-3 SVT(2.00)		
APPROVED	K.T	06/12/03	AUDIO:AD1981B		
CLASS					
THIS DOCUMENT IS THE PROPERTY OF IBM ITS USE IS AUTHORIZED ONLY FOR RESPONDING TO A REQUEST FOR QUOTATION OR FOR THE PERFORMANCE OF WORK FOR IBM. ALL QUESTIONS MUST BE REFERRED TO THE IBM PURCHASING DEPARTMENT.					IBM CONFIDENTIAL

93P4047

PLACE NEAR C244

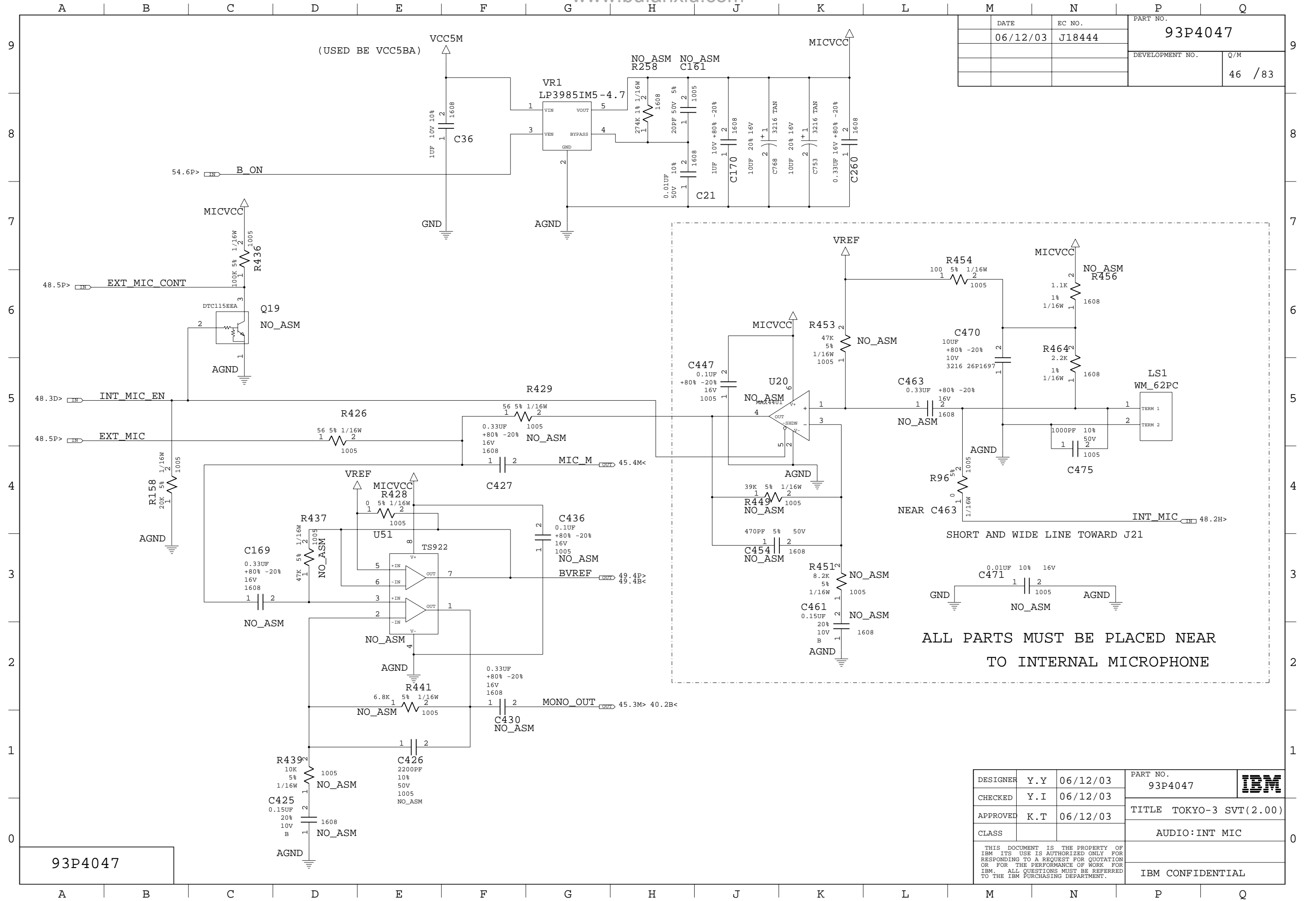

DATE	EC NO.	PART NO.
06/12/03	J18444	93P4047
		DEVELOPMENT NO.
		Q/M
		46 / 83

DESIGNER	Y.Y	06/12/03	PART NO.	93P4047	IBM
CHECKED	Y.I	06/12/03	TITLE TOKYO-3 SVT(2.00)		
APPROVED	K.T	06/12/03	AUDIO:INT MIC		
CLASS					
THIS DOCUMENT IS THE PROPERTY OF IBM ITS USE IS AUTHORIZED ONLY FOR RESPONDING TO A REQUEST FOR QUOTATION OR FOR THE PERFORMANCE OF WORK FOR IBM. ALL QUESTIONS MUST BE REFERRED TO THE IBM PURCHASING DEPARTMENT.					IBM CONFIDENTIAL

93P4047

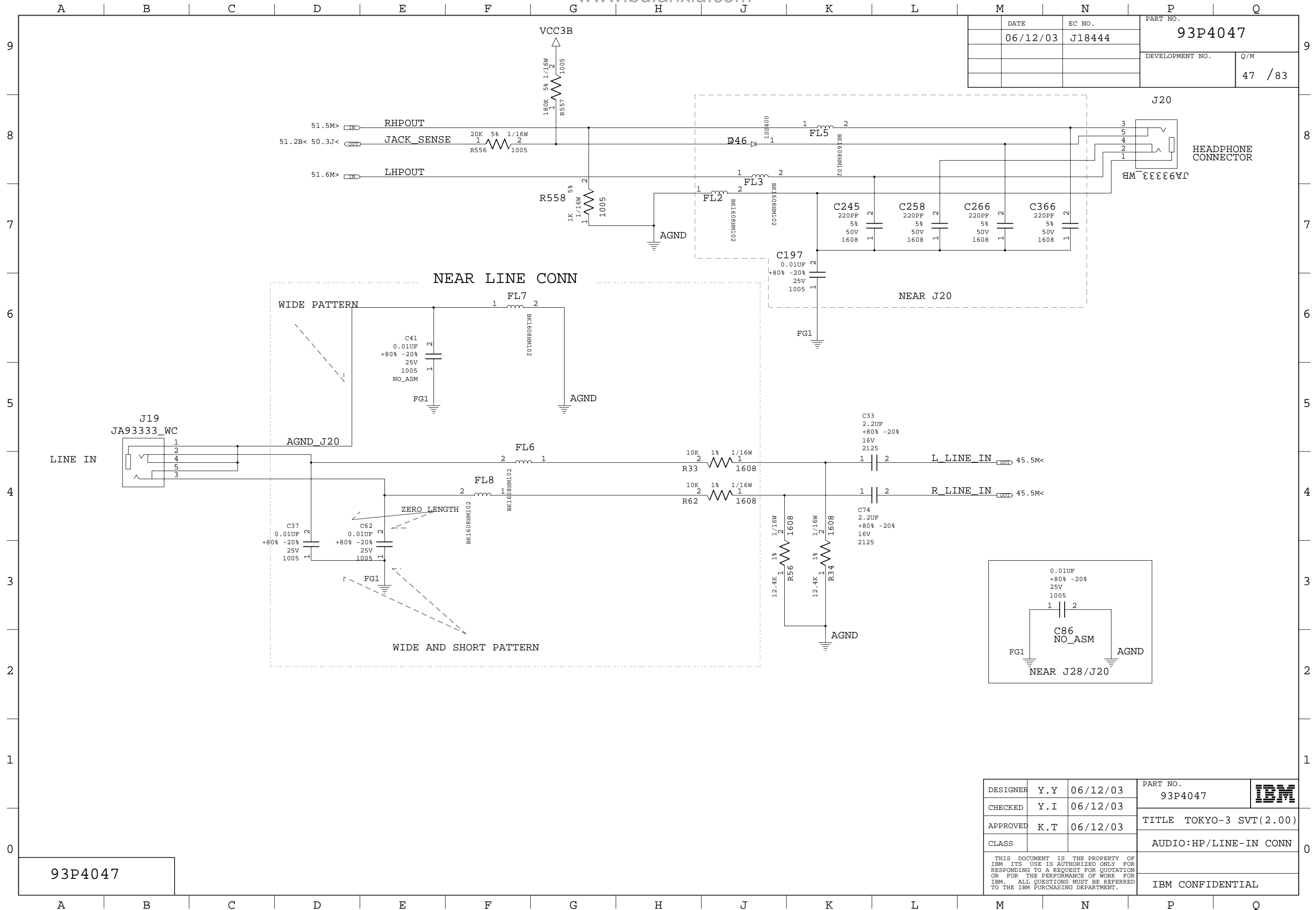

DATE	EC NO.	PART NO.
06/12/03	J18444	93P4047
DEVELOPMENT NO.		Q/M
		47 / 83

DESIGNER	Y.Y	06/12/03	PART NO.	93P4047	IBM
CHECKED	Y.I	06/12/03	TITLE		
APPROVED	K.T	06/12/03	CLASS	AUDIO:HP/LINE-IN CONN	
THIS DOCUMENT IS THE PROPERTY OF IBM ITS USE IS AUTHORIZED ONLY FOR RESPONDING TO A REQUEST FOR QUOTATION OR FOR THE PERFORMANCE OF WORK FOR IBM. ALL QUESTIONS MUST BE REFERRED TO THE IBM PURCHASING DEPARTMENT.					IBM CONFIDENTIAL

93P4047

DATE	EC NO.	PART NO.	
06/12/03	J18444	93P4047	
		DEVELOPMENT NO.	Q/M
			48 / 83

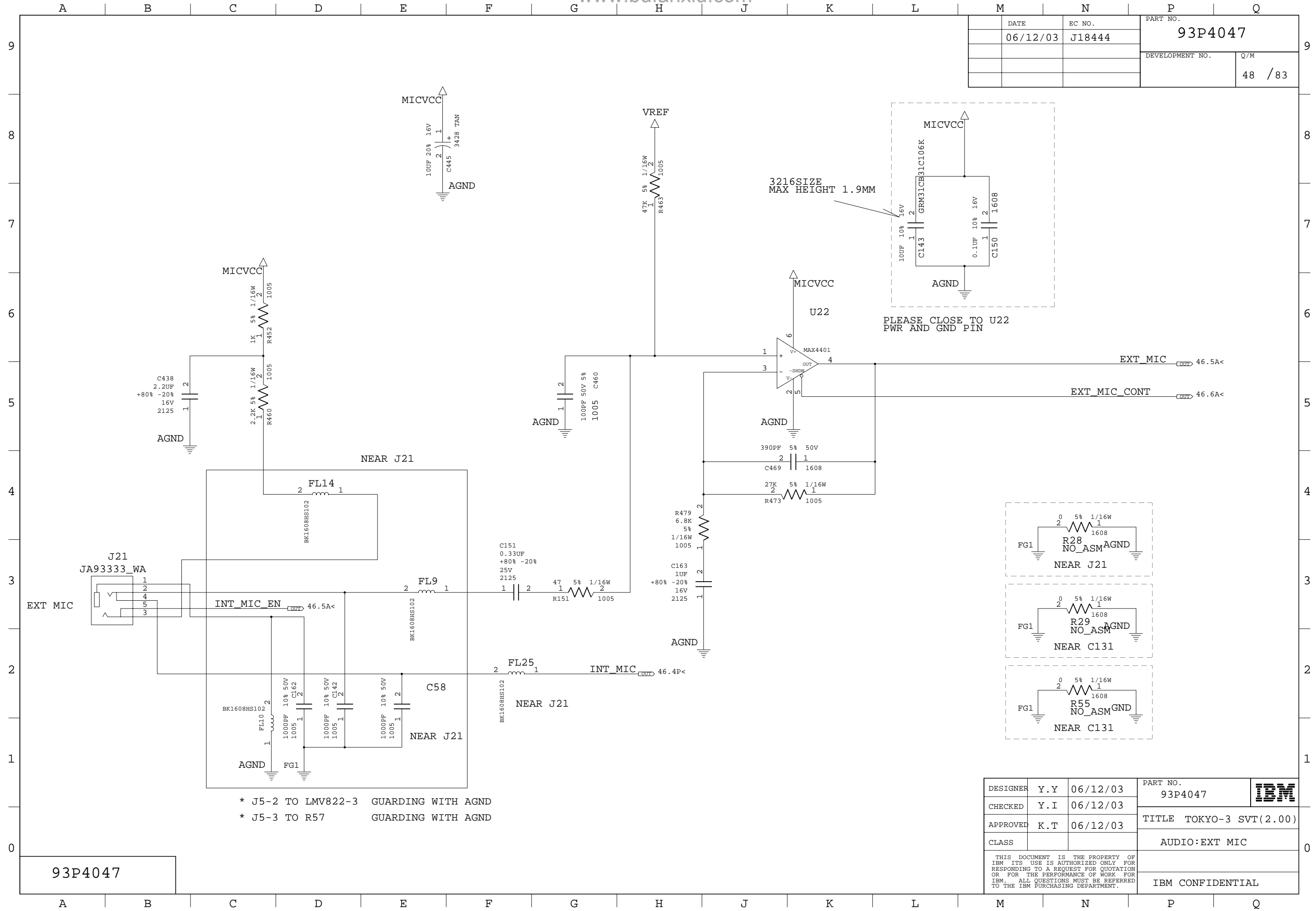

* J5-2 TO LMV822-3 GUARDING WITH AGND
 * J5-3 TO R57 GUARDING WITH AGND

DESIGNER	Y.Y	06/12/03	PART NO.	93P4047	IBM
CHECKED	Y.I	06/12/03	TITLE TOKYO-3 SVT(2.00)		
APPROVED	K.T	06/12/03	AUDIO:EXT MIC		
CLASS			THIS DOCUMENT IS THE PROPERTY OF IBM ITS USE IS AUTHORIZED ONLY FOR RESPONDING TO A REQUEST FOR QUOTATION OR FOR THE PERFORMANCE OF WORK FOR IBM. ALL QUESTIONS MUST BE REFERRED TO THE IBM PURCHASING DEPARTMENT.		IBM CONFIDENTIAL

93P4047

DATE	06/12/03	EC NO.	J18444	PART NO.	93P4047	
DEVELOPMENT NO.			Q/M			
			49 /83			

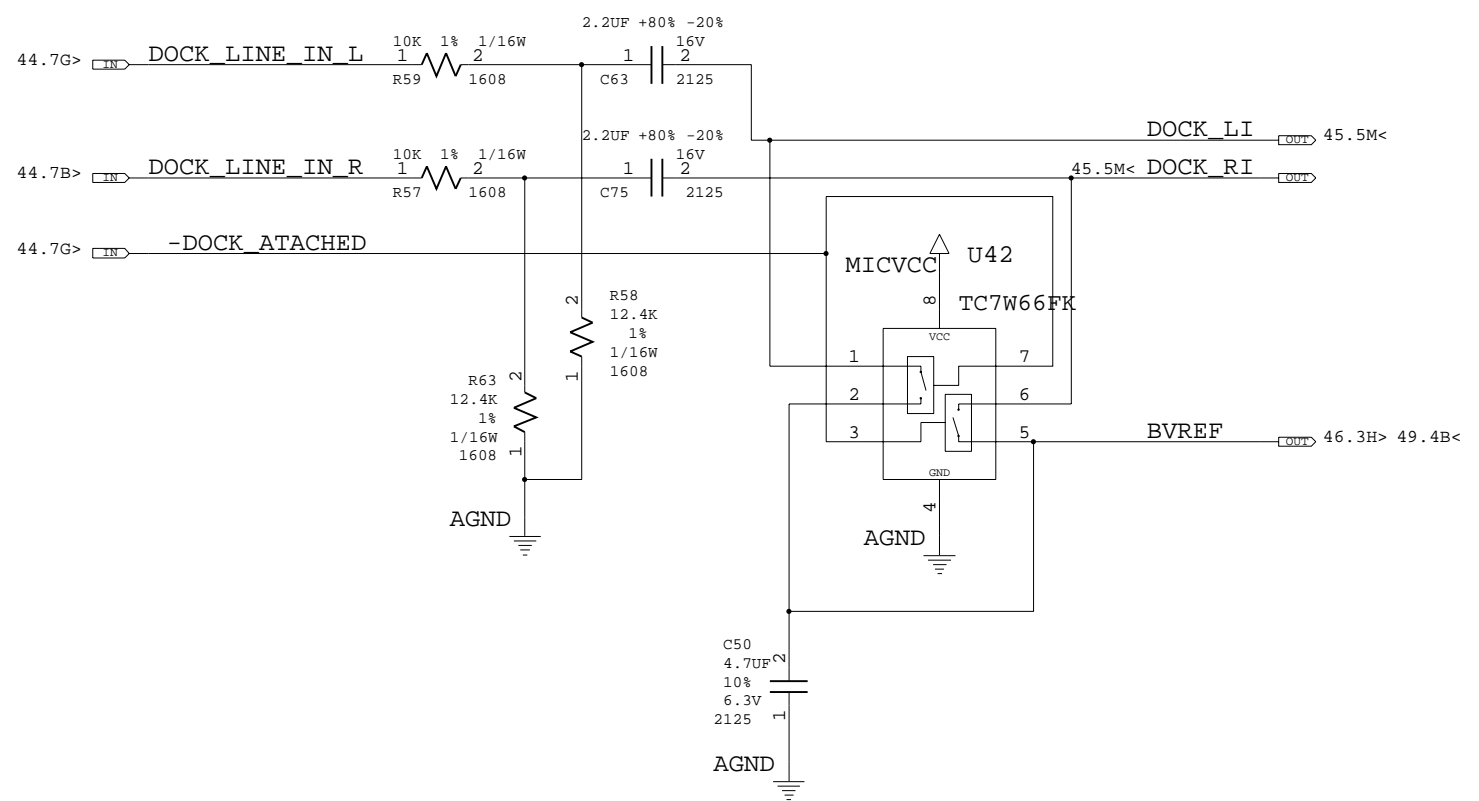
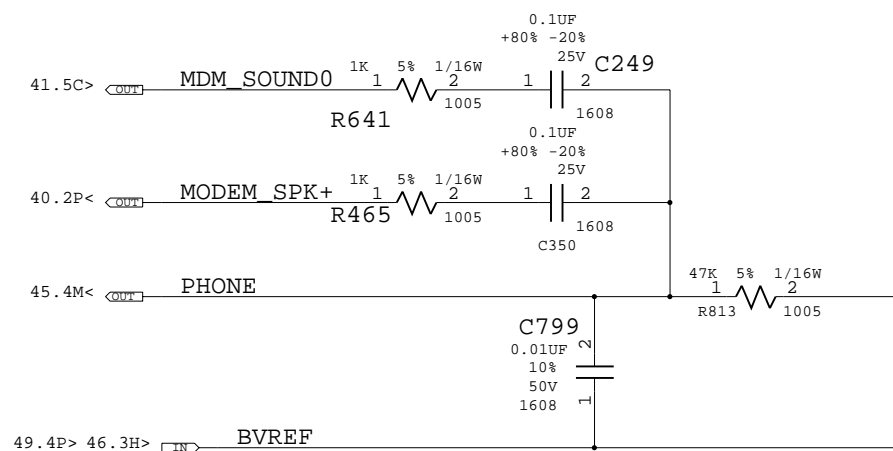

93P4047

DESIGNER	Y.Y	06/12/03	PART NO.	93P4047	IBM
CHECKED	Y.I	06/12/03	TITLE TOKYO-3 SVT(2.00)		
APPROVED	K.T	06/12/03	CLASS		AUDIO MISC(1/2)
THIS DOCUMENT IS THE PROPERTY OF IBM ITS USE IS AUTHORIZED ONLY FOR RESPONDING TO A REQUEST FOR QUOTATION OR FOR THE PERFORMANCE OF WORK FOR IBM. ALL QUESTIONS MUST BE REFERRED TO THE IBM PURCHASING DEPARTMENT.					IBM CONFIDENTIAL

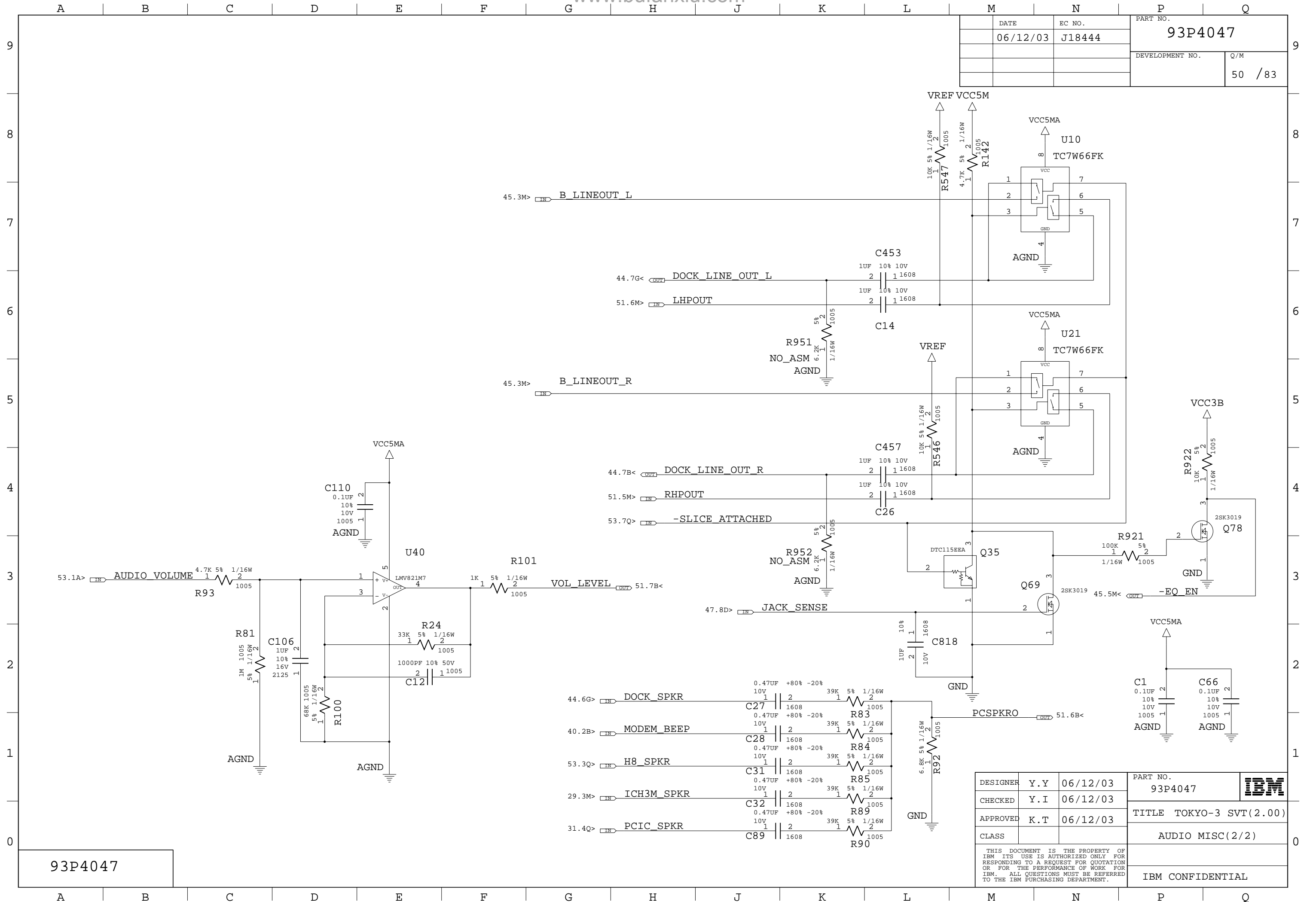

DATE	EC NO.	PART NO.	
06/12/03	J18444	93P4047	
		DEVELOPMENT NO.	Q/M
			50 / 83

93P4047

DESIGNER	Y.Y	06/12/03	PART NO.	93P4047	IBM
CHECKED	Y.I	06/12/03	TITLE		
APPROVED	K.T	06/12/03	AUDIO MISC(2/2)		
CLASS			IBM CONFIDENTIAL		

THIS DOCUMENT IS THE PROPERTY OF IBM ITS USE IS AUTHORIZED ONLY FOR RESPONDING TO A REQUEST FOR QUOTATION OR FOR THE PERFORMANCE OF WORK FOR IBM. ALL QUESTIONS MUST BE REFERRED TO THE IBM PURCHASING DEPARTMENT.

DATE	EC NO.	PART NO.	
06/12/03	J18444	93P4047	
		DEVELOPMENT NO.	Q/M
			51 / 83

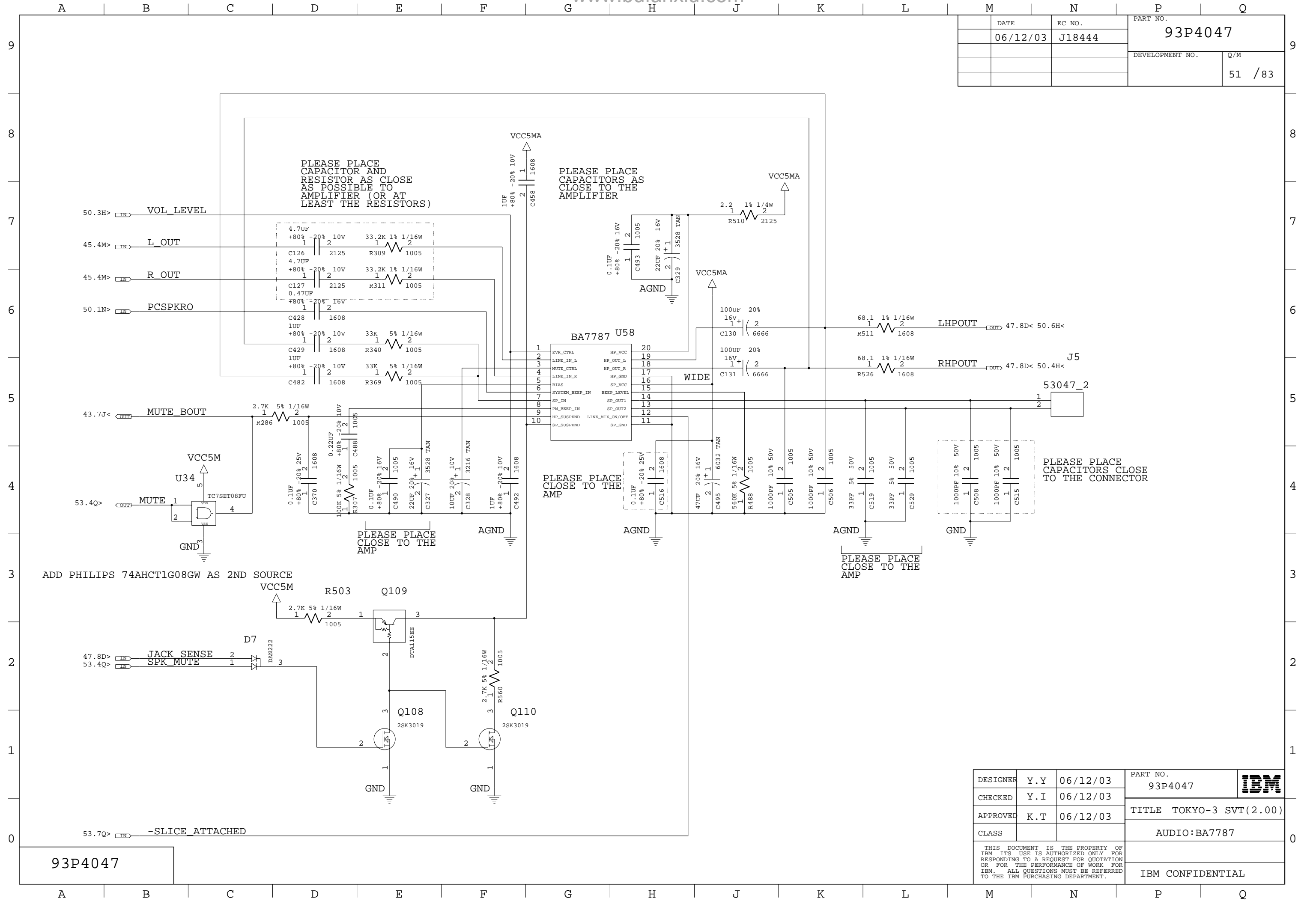

93P4047

DESIGNER	Y.Y	06/12/03	PART NO.	93P4047	
CHECKED	Y.I	06/12/03	TITLE TOKYO-3 SVT(2.00)		
APPROVED	K.T	06/12/03	CLASS		AUDIO:BA7787
THIS DOCUMENT IS THE PROPERTY OF IBM ITS USE IS AUTHORIZED ONLY FOR RESPONDING TO A REQUEST FOR QUOTATION OR FOR THE PERFORMANCE OF WORK FOR IBM. ALL QUESTIONS MUST BE REFERRED TO THE IBM PURCHASING DEPARTMENT.					IBM CONFIDENTIAL

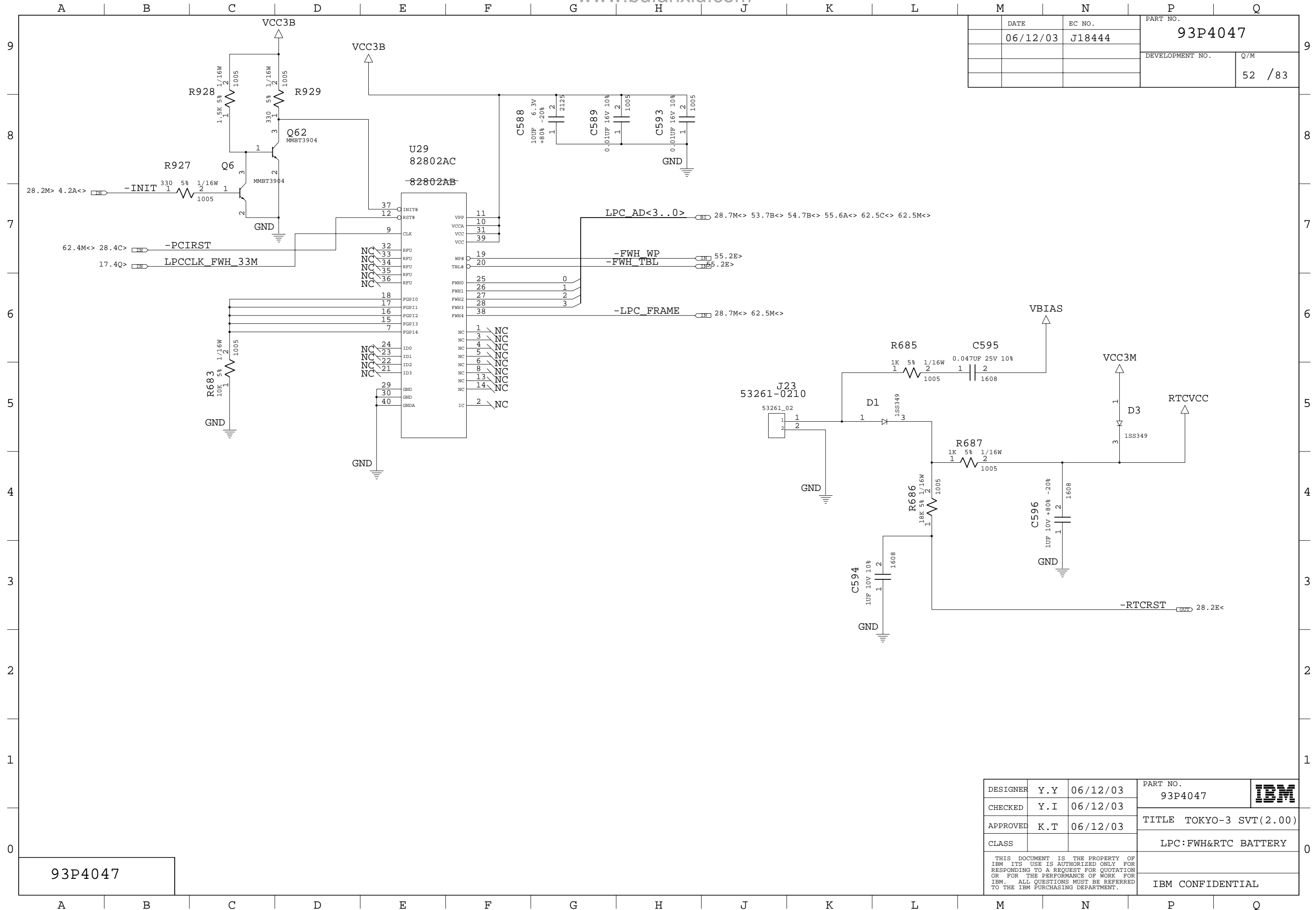

DATE	EC NO.	PART NO.	
06/12/03	J18444	93P4047	
		DEVELOPMENT NO.	Q/M
			52 / 83

93P4047

DESIGNER	Y.Y	06/12/03	PART NO.	93P4047	
CHECKED	Y.I	06/12/03	TITLE		
APPROVED	K.T	06/12/03	CLASS	LPC:FHW&RTC BATTERY	
THIS DOCUMENT IS THE PROPERTY OF IBM ITS USE IS AUTHORIZED ONLY FOR RESPONDING TO A REQUEST FOR QUOTATION OR FOR THE PERFORMANCE OF WORK FOR IBM. ALL QUESTIONS MUST BE REFERRED TO THE IBM PURCHASING DEPARTMENT.					IBM CONFIDENTIAL

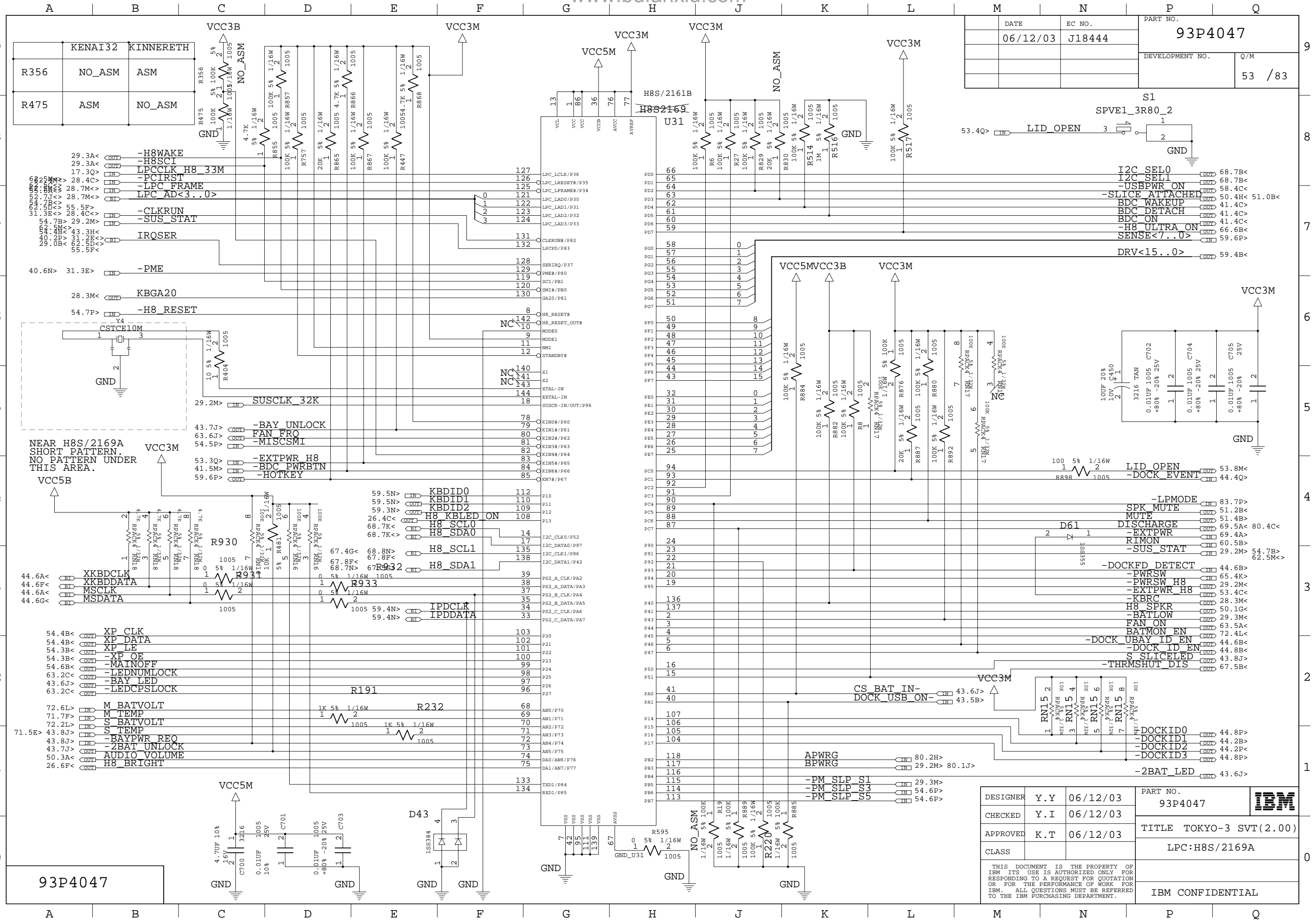

DATE	EC NO.	PART NO.
06/12/03	J18444	93P4047
DEVELOPMENT NO.		Q/M
		53 / 83

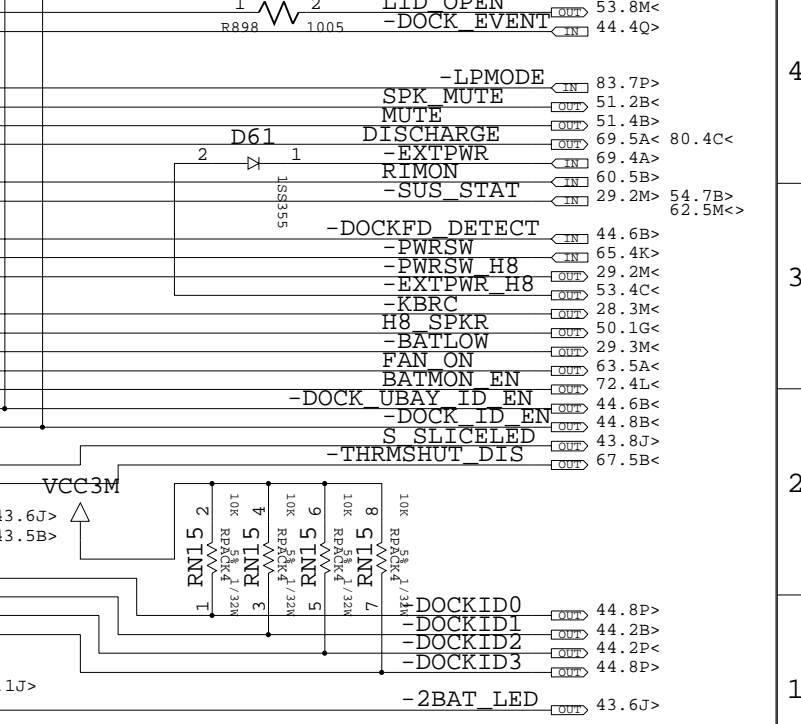
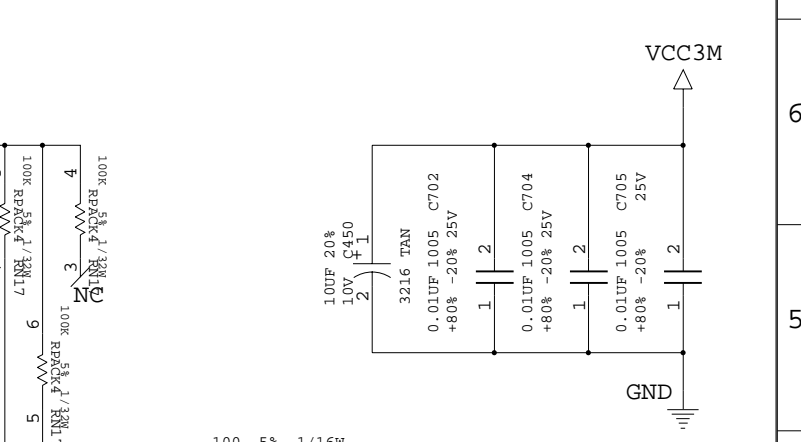
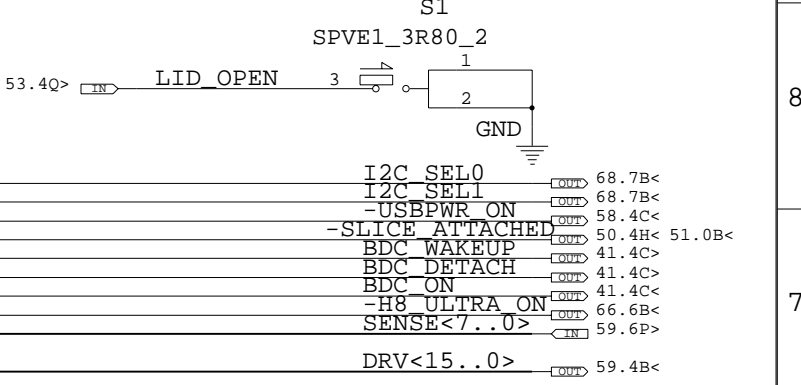

DESIGNER	Y.Y	06/12/03	PART NO.	93P4047	
CHECKED	Y.I	06/12/03	TITLE TOKYO-3 SVT(2.00)		
APPROVED	K.T	06/12/03	LPC:H8S/2169A		IBM CONFIDENTIAL
CLASS	THIS DOCUMENT IS THE PROPERTY OF IBM ITS USE IS AUTHORIZED ONLY FOR RESPONDING TO A REQUEST FOR QUOTATION OR FOR THE PERFORMANCE OF WORK FOR IBM. ALL QUESTIONS MUST BE REFERRED TO THE IBM PURCHASING DEPARTMENT.				

93P4047

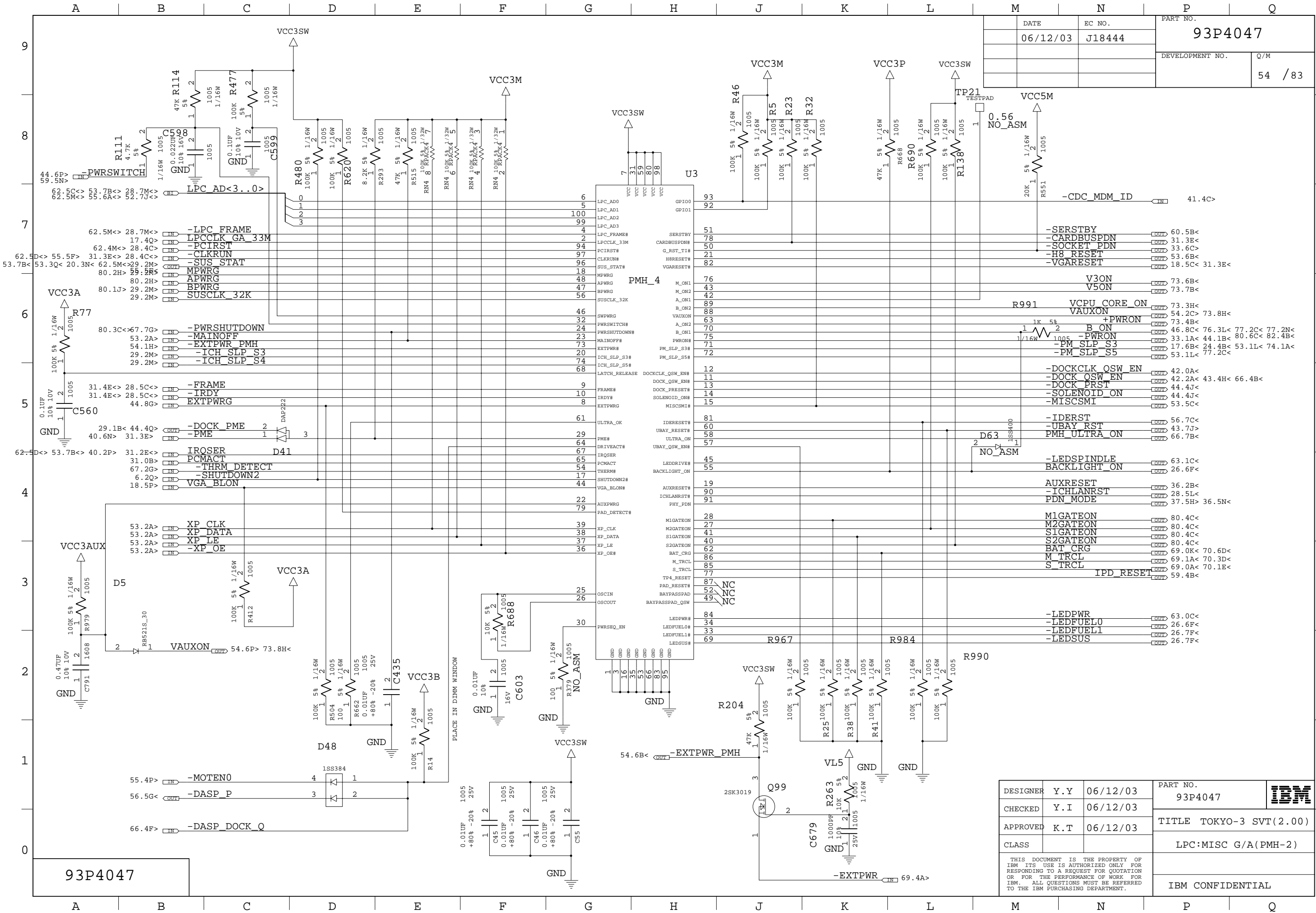

DATE	EC NO.	PART NO.	
06/12/03	J18444	93P4047	
DEVELOPMENT NO.		Q/M	
		54	/83

Pin	Signal Name	Level
93	GPI00	41.4C<
92	GPI01	41.4C<
51	SERSTBY	60.5B<
78	CARDBUSPDN	31.3E<
50	G_RST_TI#	33.6C>
21	H8RESET	53.6B<
82	VGARESET	18.5C< 31.3E<
76	PMH_4	
43	M_ON1	73.6B<
42	M_ON2	73.7B<
89	A_ON1	
88	B_ON2	
63	VAUXON	73.3H<
70	A_ON2	54.2C> 73.8H<
75	PMON#	73.4B<
71	PM_SLP_S3#	46.8C< 76.3L< 77.2C< 77.2N<
72	PM_SLP_S5#	33.1A< 44.1B< 80.6C< 82.4B<
12	LATCH_RELEASE	17.6B< 24.4B< 53.1L< 74.1A<
11	DOCKCLK_QSW_EN#	42.0A<
13	DOCK_QSW_EN#	42.2A< 43.4H< 66.4B<
14	DOCK_PRESET#	44.4J<
15	SOLENOID_ON#	44.4J<
81	IDERSET#	56.7C<
60	UBAY_RESET#	43.7J>
58	ULTRA_ON	66.7B<
57	UBAY_QSW_EN#	
45	LEDSPINDLE	63.1C<
55	BACKLIGHT_ON	26.6F<
19	AUXRESET#	36.2B<
90	ICHLANRST#	28.5L< 36.5N<
91	PHY_PDN	
28	MIGATEON	80.4C<
27	M2GATEON	80.4C<
41	SIGATEON	80.4C<
40	S2GATEON	80.4C<
62	BAT_CRG	69.0K< 70.6D<
86	M_TRCL	69.1A< 70.3D<
85	S_TRCL	69.0A< 70.1E<
77	TP4_RESET	59.4B<
87	PAD_RESET#	
52	BYPASSPAD	
49	BAYPASSPAD_QSW	
84	LEDPWR#	63.0C<
34	LEDFUELO	26.6F<
33	LEDFUEL1	26.7F<
69	LEDSUS#	26.7F<
25	OSCIN	
26	OSCOUT	
25	PWRSEQ_EN	
30		

DESIGNER	Y.Y	06/12/03	PART NO.
CHECKED	Y.I	06/12/03	93P4047
APPROVED	K.T	06/12/03	TITLE TOKYO-3 SVT(2.00)
CLASS			LPC:MISC G/A(PMH-2)

THIS DOCUMENT IS THE PROPERTY OF IBM ITS USE IS AUTHORIZED ONLY FOR RESPONDING TO A REQUEST FOR QUOTATION OR FOR THE PERFORMANCE OF WORK FOR IBM. ALL QUESTIONS MUST BE REFERRED TO THE IBM PURCHASING DEPARTMENT.

IBM CONFIDENTIAL	
------------------	--

93P4047



PLACE NEAR SUPER I/O

DATE	EC NO.	PART NO.
06/12/03	J18444	93P4047
DEVELOPMENT NO.		Q/M
		55 / 83

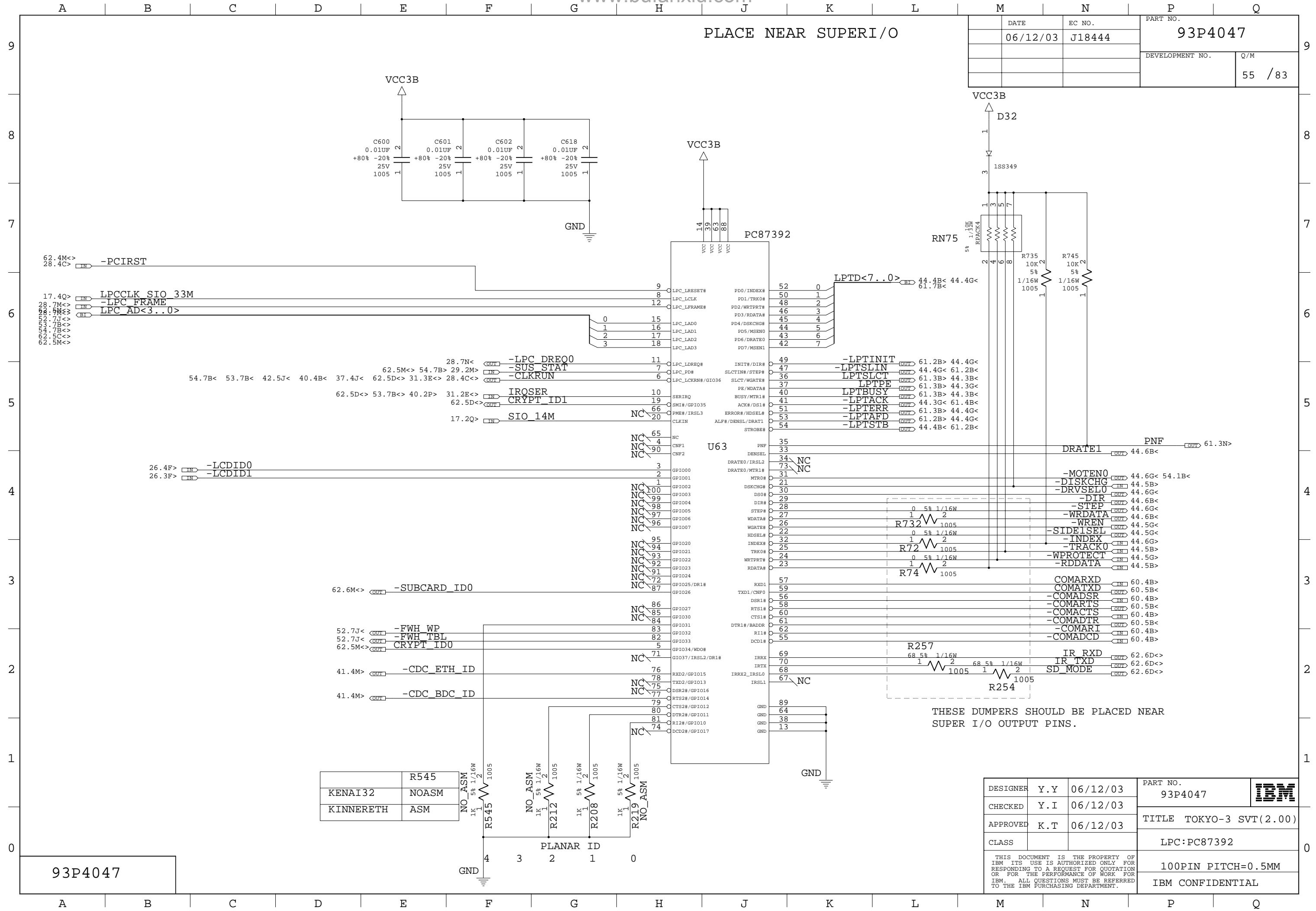

THESE DUMPERS SHOULD BE PLACED NEAR SUPER I/O OUTPUT PINS.

KENAI32	NOASM
KINNERETH	ASM

DESIGNER	Y.Y	06/12/03	PART NO.	93P4047	IBM
CHECKED	Y.I	06/12/03	TITLE TOKYO-3 SVT(2.00)		
APPROVED	K.T	06/12/03	LPC:PC87392		
CLASS			100PIN PITCH=0.5MM		
THIS DOCUMENT IS THE PROPERTY OF IBM ITS USE IS AUTHORIZED ONLY FOR RESPONDING TO A REQUEST FOR QUOTATION OR FOR THE PERFORMANCE OF WORK FOR IBM. ALL QUESTIONS MUST BE REFERRED TO THE IBM PURCHASING DEPARTMENT.					IBM CONFIDENTIAL

93P4047

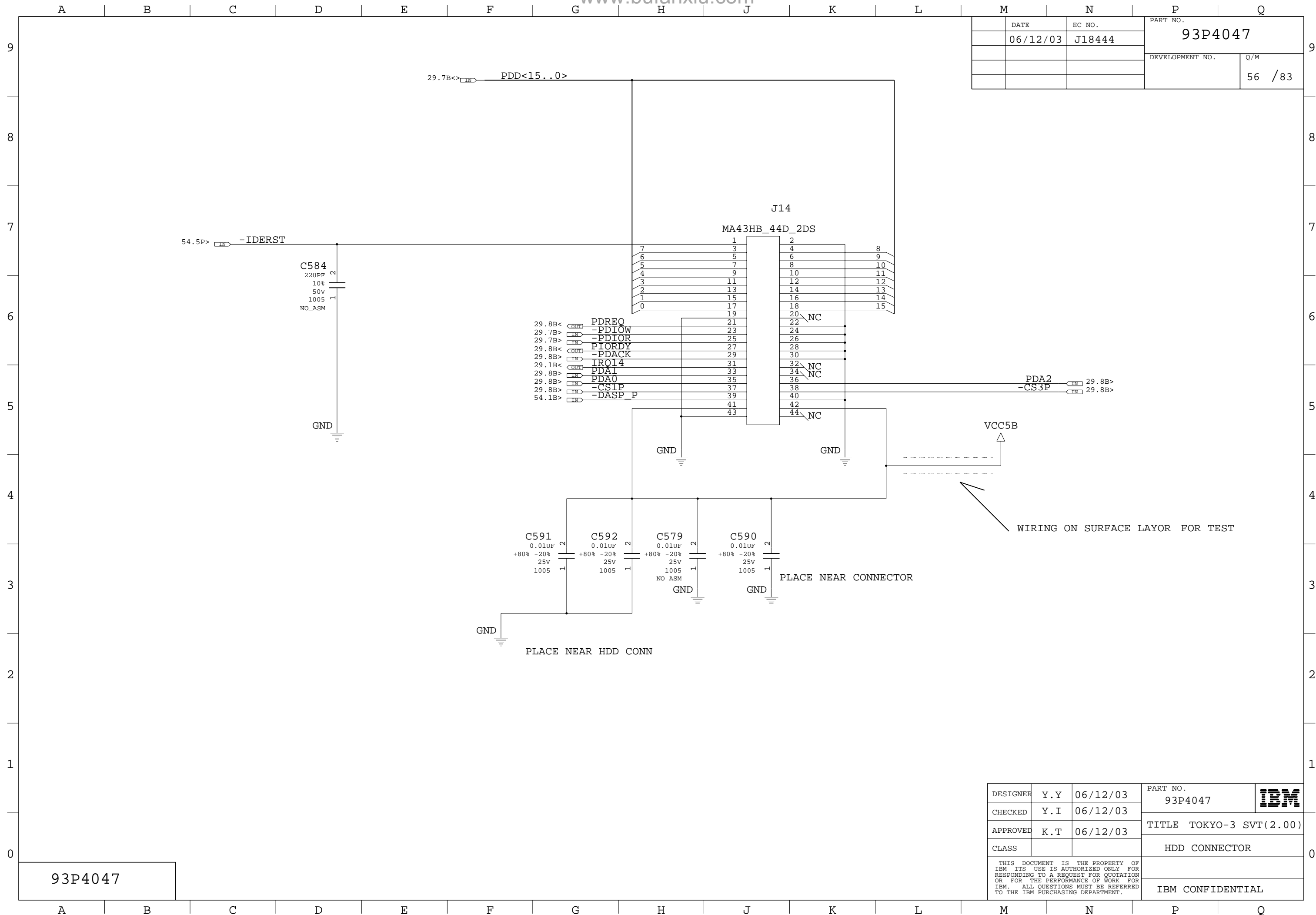

DATE	EC NO.	PART NO.	
06/12/03	J18444	93P4047	
		DEVELOPMENT NO.	Q/M
			56 /83

93P4047

DESIGNER	Y.Y	06/12/03	PART NO.	93P4047	IBM
CHECKED	Y.I	06/12/03	TITLE		
APPROVED	K.T	06/12/03	CLASS	HDD CONNECTOR	
THIS DOCUMENT IS THE PROPERTY OF IBM ITS USE IS AUTHORIZED ONLY FOR RESPONDING TO A REQUEST FOR QUOTATION OR FOR THE PERFORMANCE OF WORK FOR IBM. ALL QUESTIONS MUST BE REFERRED TO THE IBM PURCHASING DEPARTMENT.				IBM CONFIDENTIAL	

DATE	EC NO.	PART NO.	
06/12/03	J18444	93P4047	
		DEVELOPMENT NO.	Q/M
			57 / 83

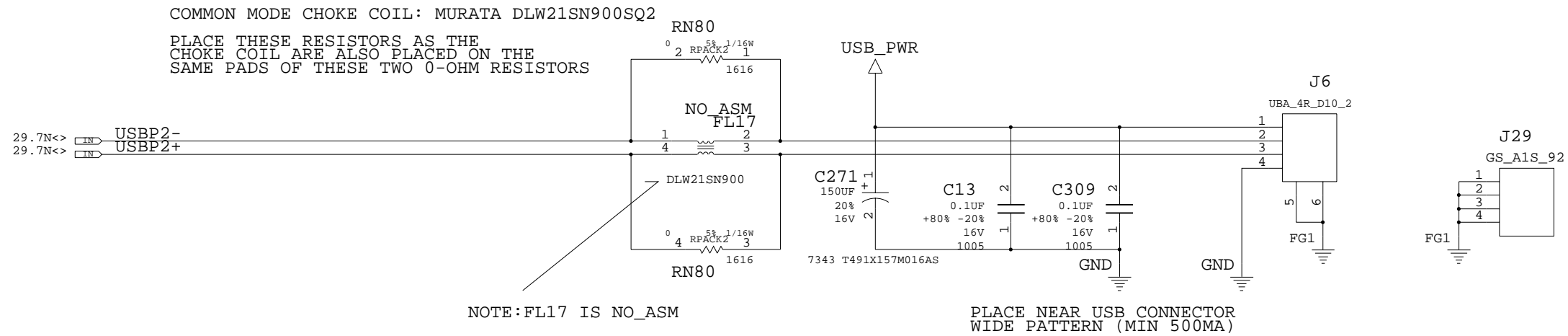

USB CONNECTOR SHIELD MUST BE CONNECTED TO USBX_FG

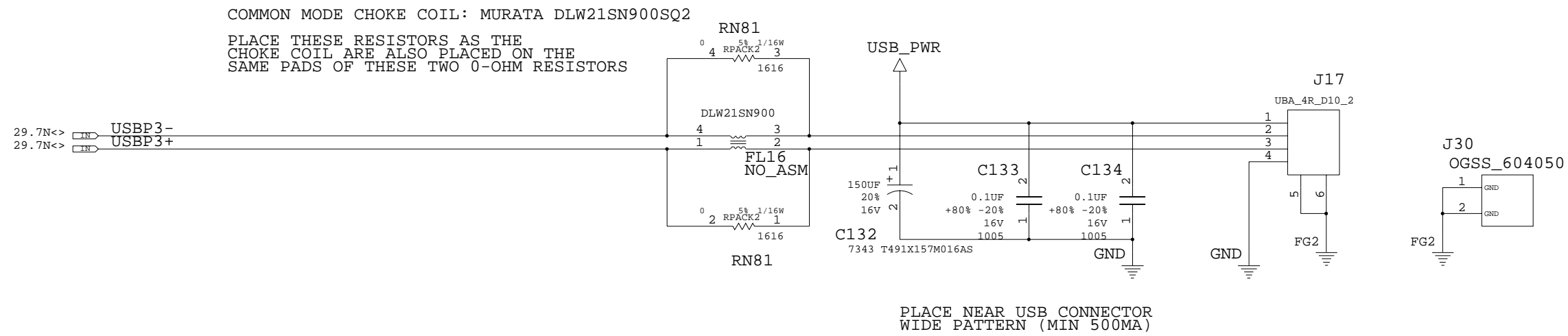

93P4047

DESIGNER	Y.Y	06/12/03	PART NO.	93P4047	
CHECKED	Y.I	06/12/03			
APPROVED	K.T	06/12/03	TITLE TOKYO-3 SVT(2.00)		
CLASS			USB CONNECTOR		
THIS DOCUMENT IS THE PROPERTY OF IBM ITS USE IS AUTHORIZED ONLY FOR RESPONDING TO A REQUEST FOR QUOTATION OR FOR THE PERFORMANCE OF WORK FOR IBM. ALL QUESTIONS MUST BE REFERRED TO THE IBM PURCHASING DEPARTMENT.				IBM CONFIDENTIAL	

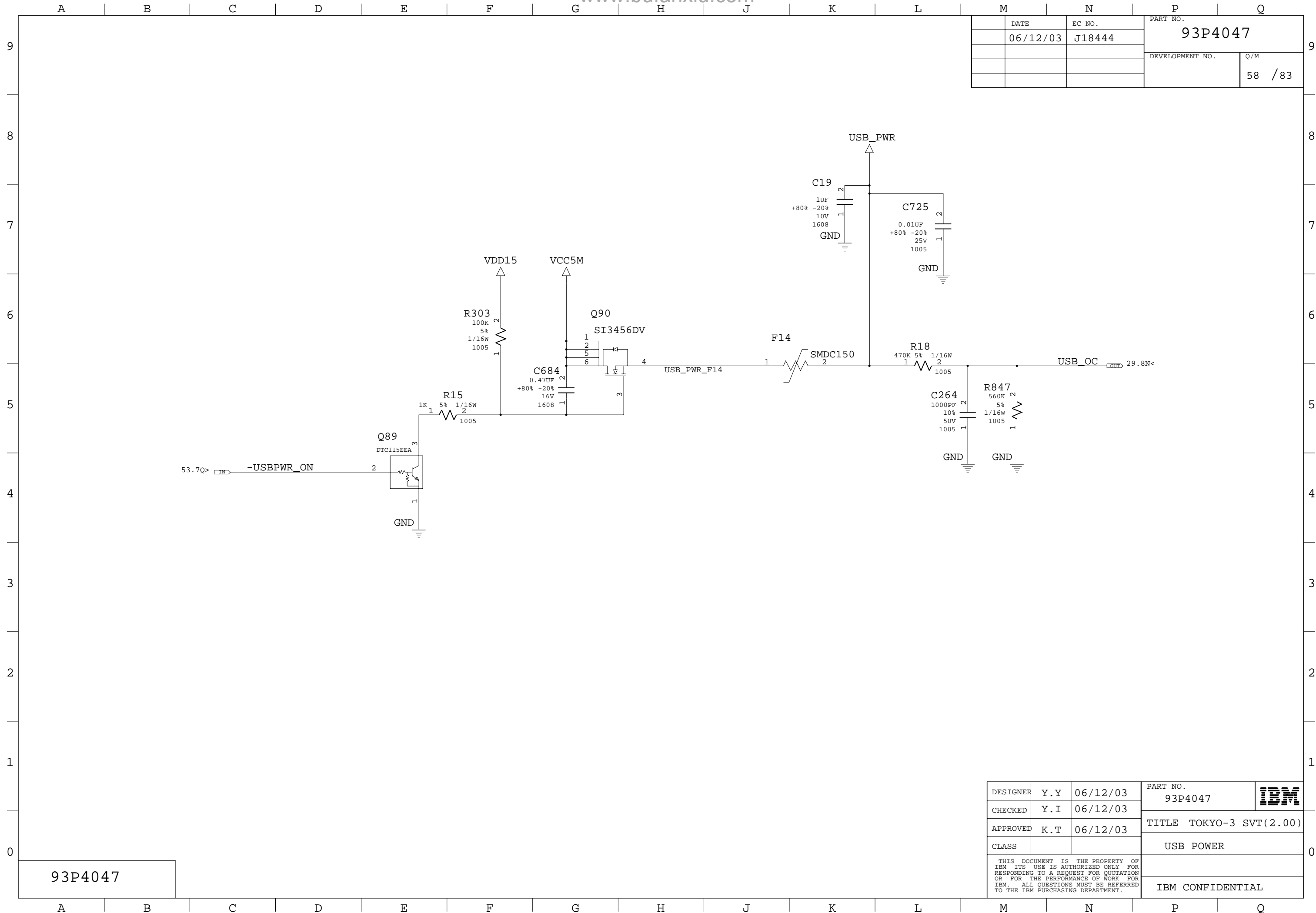

DATE	EC NO.	PART NO.	
06/12/03	J18444	93P4047	
		DEVELOPMENT NO.	Q/M
			58 /83

93P4047

DESIGNER	Y.Y	06/12/03	PART NO.	93P4047	
CHECKED	Y.I	06/12/03	TITLE		
APPROVED	K.T	06/12/03	CLASS	USB POWER	
THIS DOCUMENT IS THE PROPERTY OF IBM ITS USE IS AUTHORIZED ONLY FOR RESPONDING TO A REQUEST FOR QUOTATION OR FOR THE PERFORMANCE OF WORK FOR IBM. ALL QUESTIONS MUST BE REFERRED TO THE IBM PURCHASING DEPARTMENT.					IBM CONFIDENTIAL

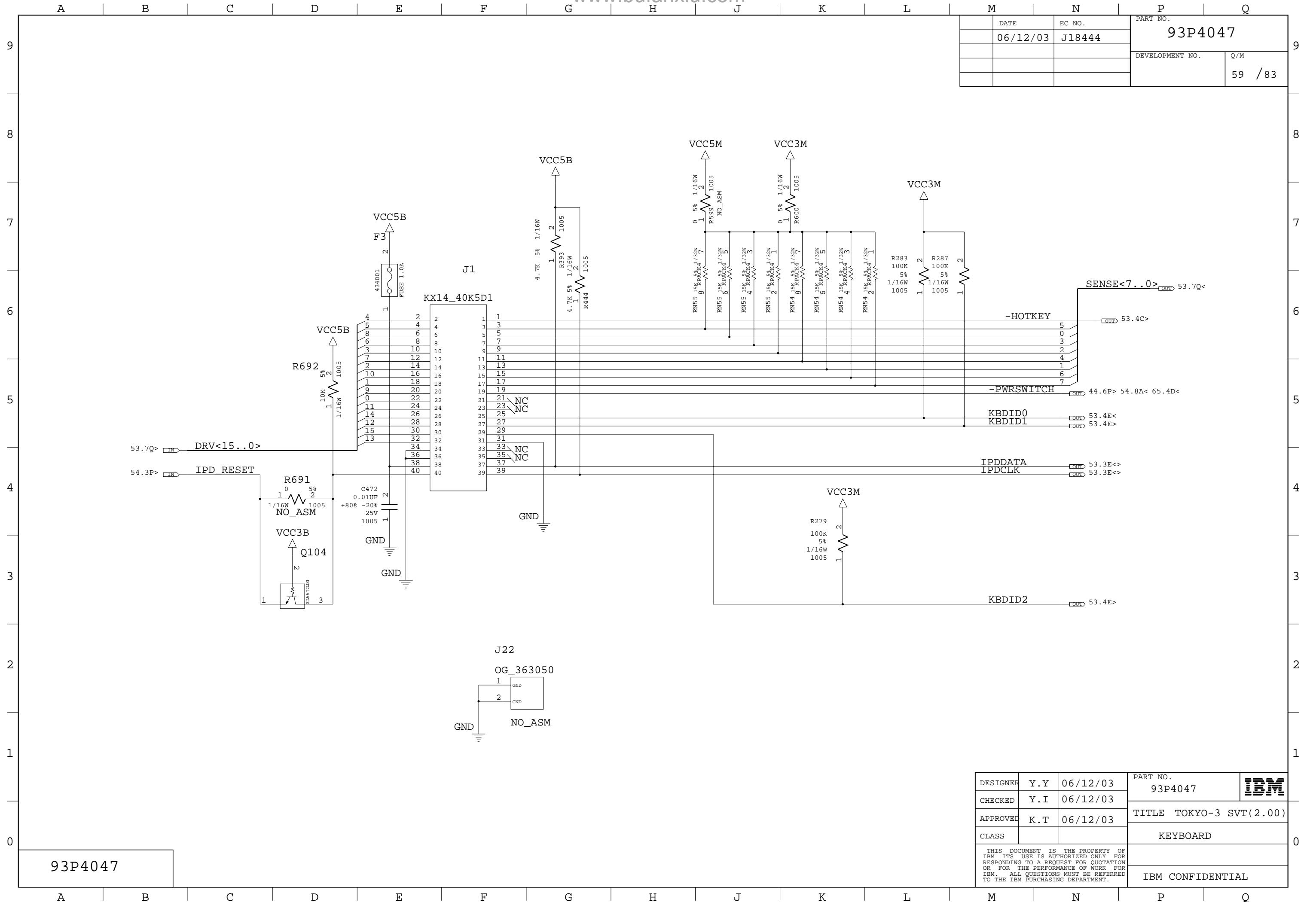

DATE	EC NO.	PART NO.	
06/12/03	J18444	93P4047	
		DEVELOPMENT NO.	Q/M
			59 / 83

93P4047

DESIGNER	Y.Y	06/12/03	PART NO.	93P4047	IBM
CHECKED	Y.I	06/12/03			
APPROVED	K.T	06/12/03	TITLE TOKYO-3 SVT(2.00)		
CLASS			KEYBOARD		
THIS DOCUMENT IS THE PROPERTY OF IBM ITS USE IS AUTHORIZED ONLY FOR RESPONDING TO A REQUEST FOR QUOTATION OR FOR THE PERFORMANCE OF WORK FOR IBM. ALL QUESTIONS MUST BE REFERRED TO THE IBM PURCHASING DEPARTMENT.					IBM CONFIDENTIAL

DATE	EC NO.	PART NO.	
06/12/03	J18444	93P4047	
		DEVELOPMENT NO.	Q/M
			60 /83

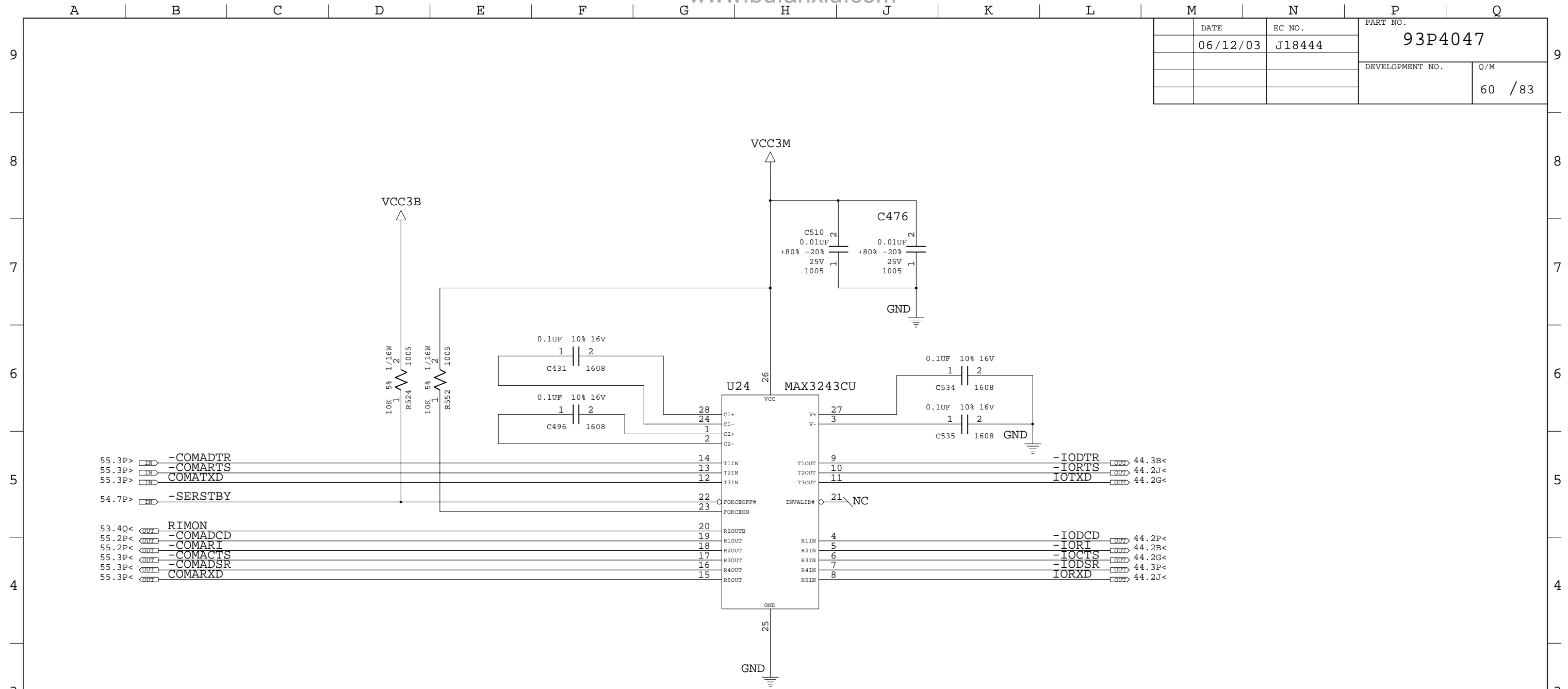

R1IN/R2IN/R3IN/R5IN HAVE INTERNAL PULLDOWN(5K OHM).
 DO NOT WIRE SIGNALS UNDER PINS (1/2/3/24/25/26/27/28)
 CHARGE PUMP CAPACITOR SHOULD BE PLACED NEAR PINS(1/2/3/24/27/28)
 ADD GND SHILED UNDER CHARGE PUMP CIRCUIT TO
 PROTECT POWER LINE NOISE
 CAPACITORS FOR CHARGE PUMP SHOULD BE USED TYPE B AND LOW ESR TYPE.

	NOMAL MODE	POWER DOWN MODE	AUTO POWER DOWN MODE
FORCEON	HIGH	DO NOT CARE	LOW
FORCEOFF	HIGH	LOW	HIGH

93P4047

DESIGNER	Y.Y	06/12/03	PART NO.	93P4047	IBM
CHECKED	Y.I	06/12/03	TITLE TOKYO-3 SVT(2.00)		
APPROVED	K.T	06/12/03	SERIAL DRIVER		
CLASS			IBM CONFIDENTIAL		

THIS DOCUMENT IS THE PROPERTY OF IBM ITS USE IS AUTHORIZED ONLY FOR RESPONDING TO A REQUEST FOR QUOTATION OR FOR THE PERFORMANCE OF WORK FOR IBM. ALL QUESTIONS MUST BE REFERRED TO THE IBM PURCHASING DEPARTMENT.

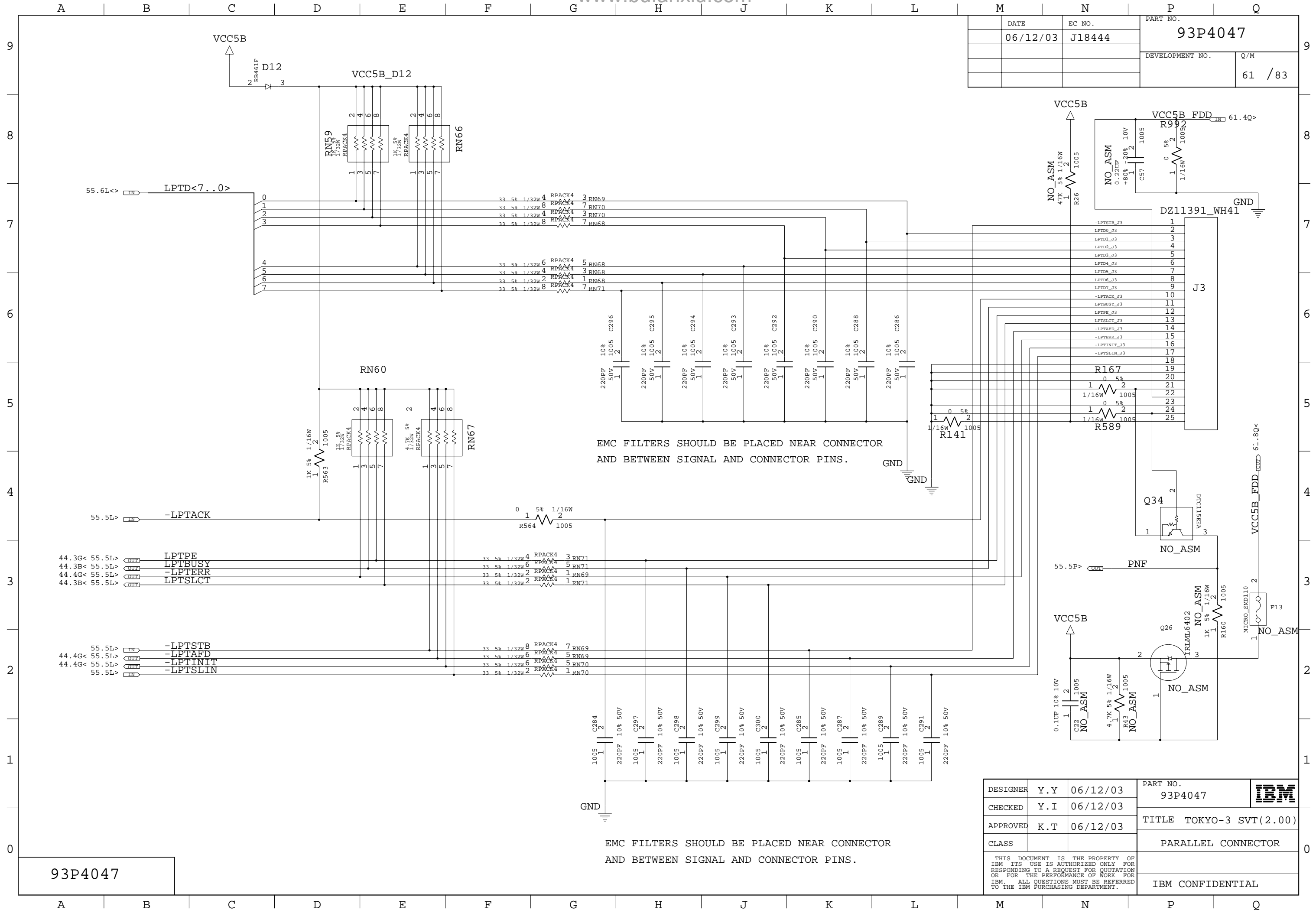

DATE	EC NO.	PART NO.	
06/12/03	J18444	93P4047	
		DEVELOPMENT NO.	Q/M
		61	/83

93P4047

DESIGNER	Y.Y	06/12/03	PART NO.	93P4047	
CHECKED	Y.I	06/12/03	TITLE TOKYO-3 SVT(2.00)		
APPROVED	K.T	06/12/03	PARALLEL CONNECTOR		
CLASS					
THIS DOCUMENT IS THE PROPERTY OF IBM ITS USE IS AUTHORIZED ONLY FOR RESPONDING TO A REQUEST FOR QUOTATION OR FOR THE PERFORMANCE OF WORK FOR IBM. ALL QUESTIONS MUST BE REFERRED TO THE IBM PURCHASING DEPARTMENT.					IBM CONFIDENTIAL

DATE		EC NO.		PART NO.	
06/12/03		J18444		93P4047	
DEVELOPMENT NO.				Q/M	
				62 /83	

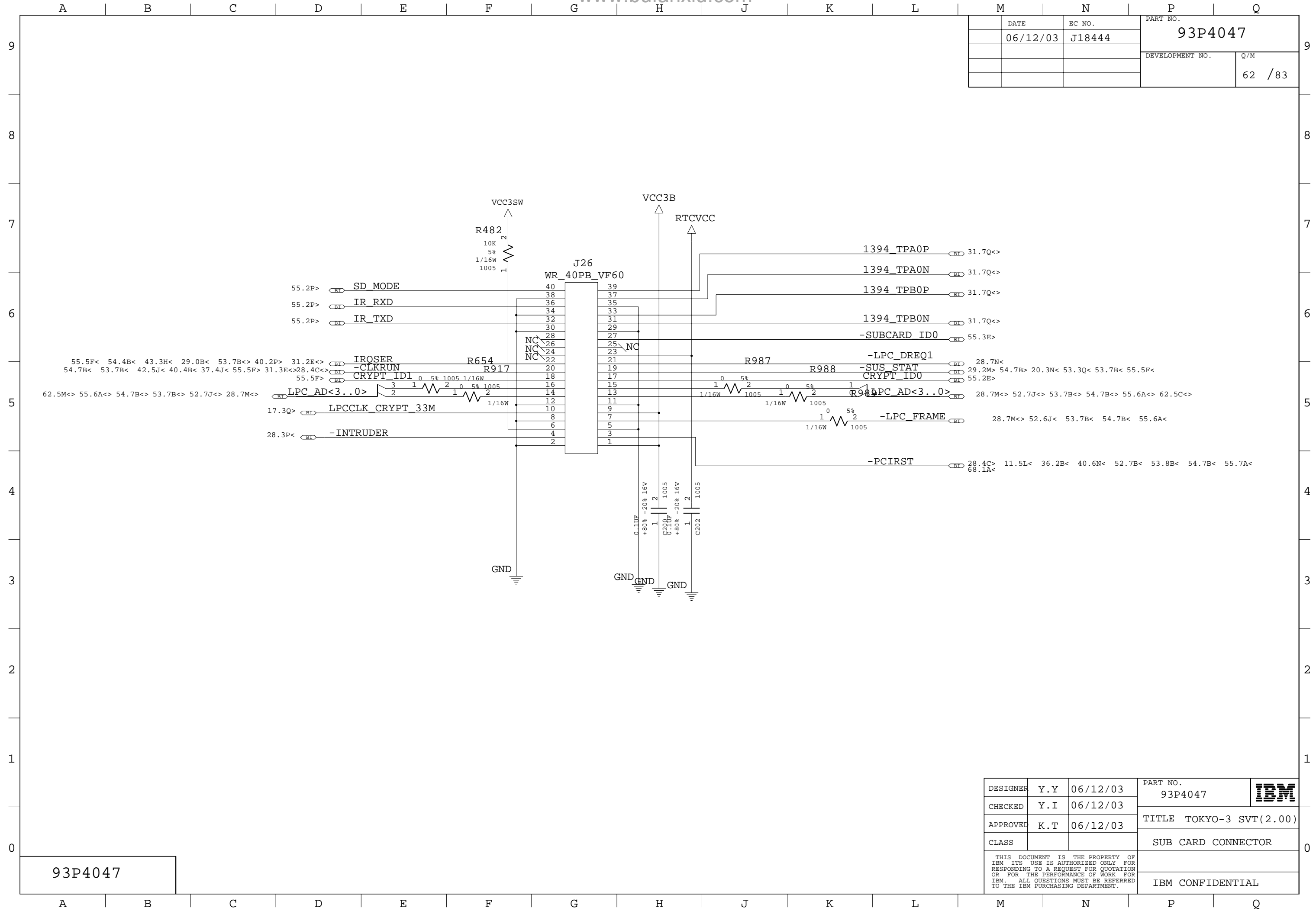

93P4047

DESIGNER	Y.Y	06/12/03	PART NO.	93P4047	
CHECKED	Y.I	06/12/03	TITLE TOKYO-3 SVT(2.00)		
APPROVED	K.T	06/12/03	SUB CARD CONNECTOR		
CLASS			THIS DOCUMENT IS THE PROPERTY OF IBM ITS USE IS AUTHORIZED ONLY FOR RESPONDING TO A REQUEST FOR QUOTATION OR FOR THE PERFORMANCE OF WORK FOR IBM. ALL QUESTIONS MUST BE REFERRED TO THE IBM PURCHASING DEPARTMENT.		IBM CONFIDENTIAL

DATE	06/12/03	EC NO.	J18444	PART NO.	93P4047
DEVELOPMENT NO.				Q/M	63 / 83

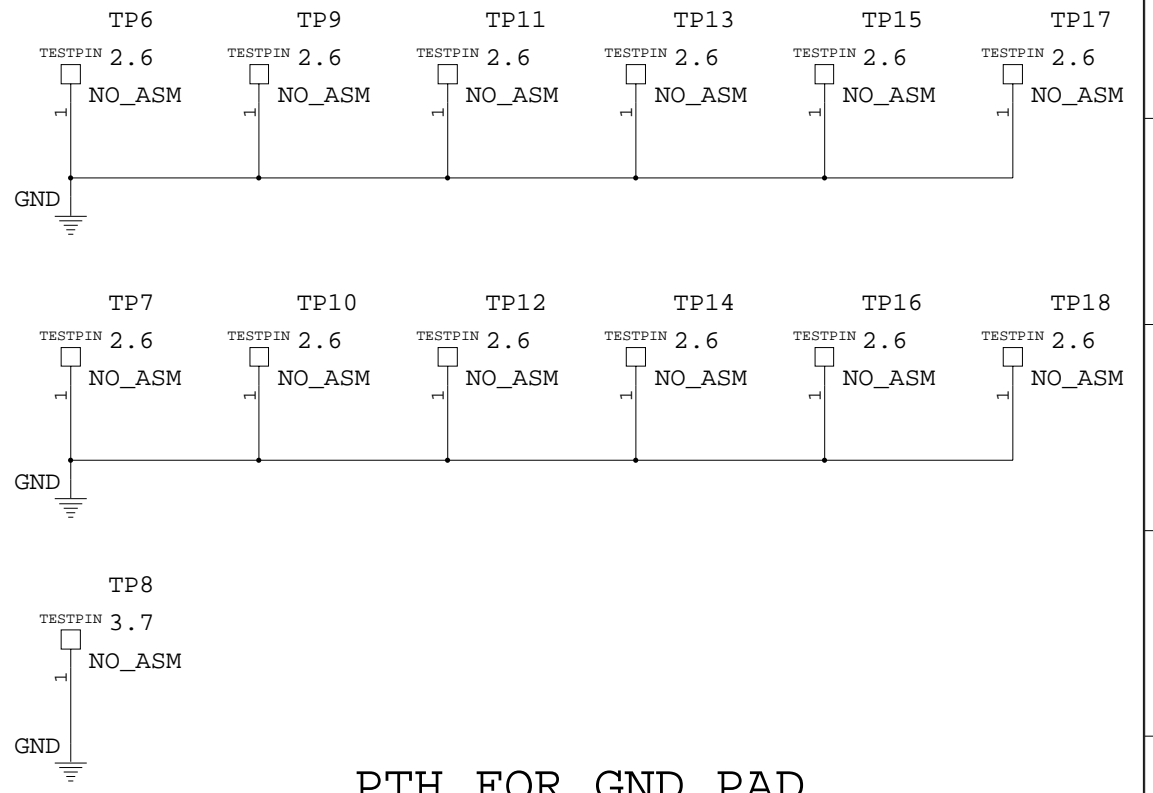
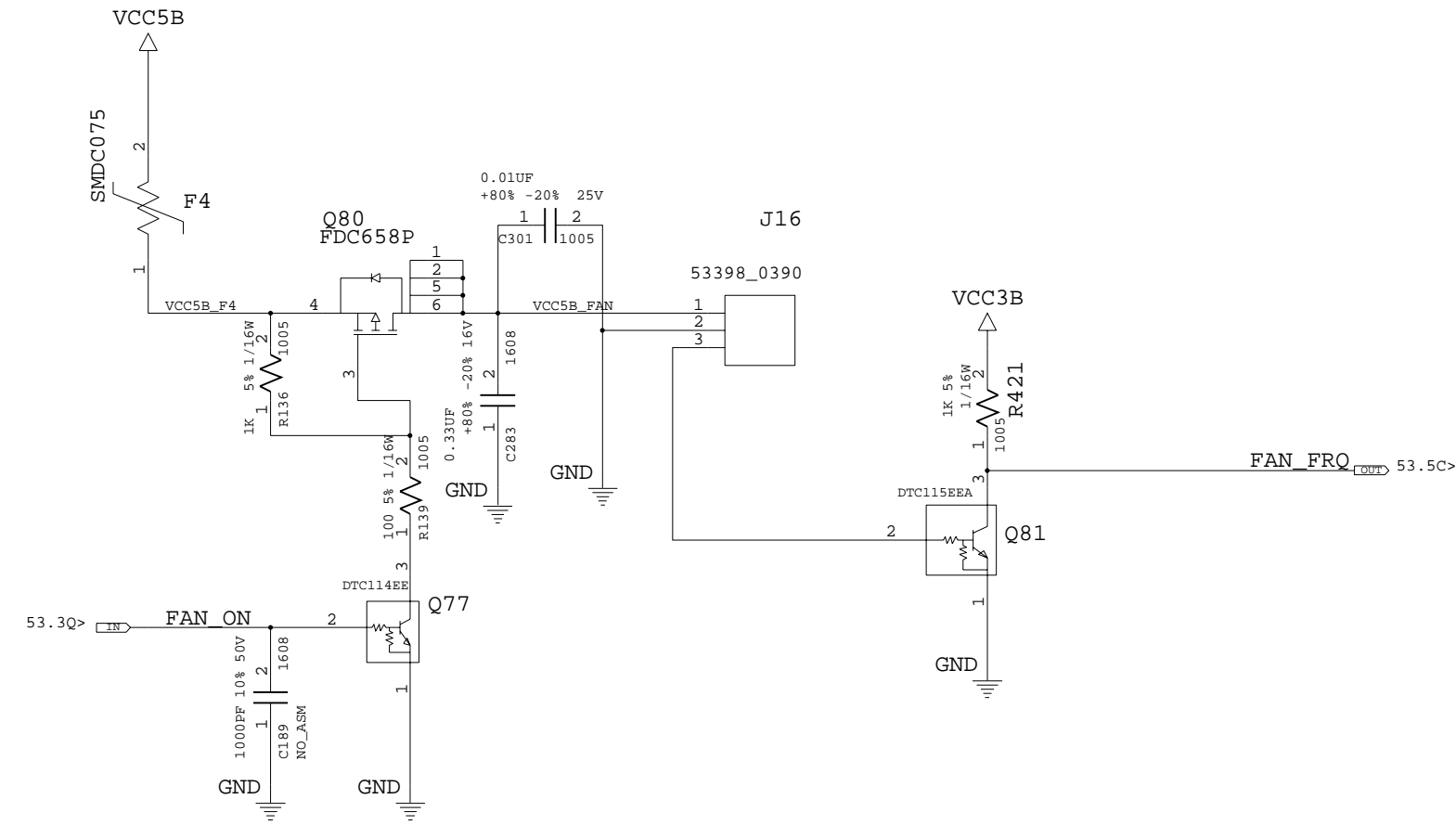

PTH FOR GND PAD

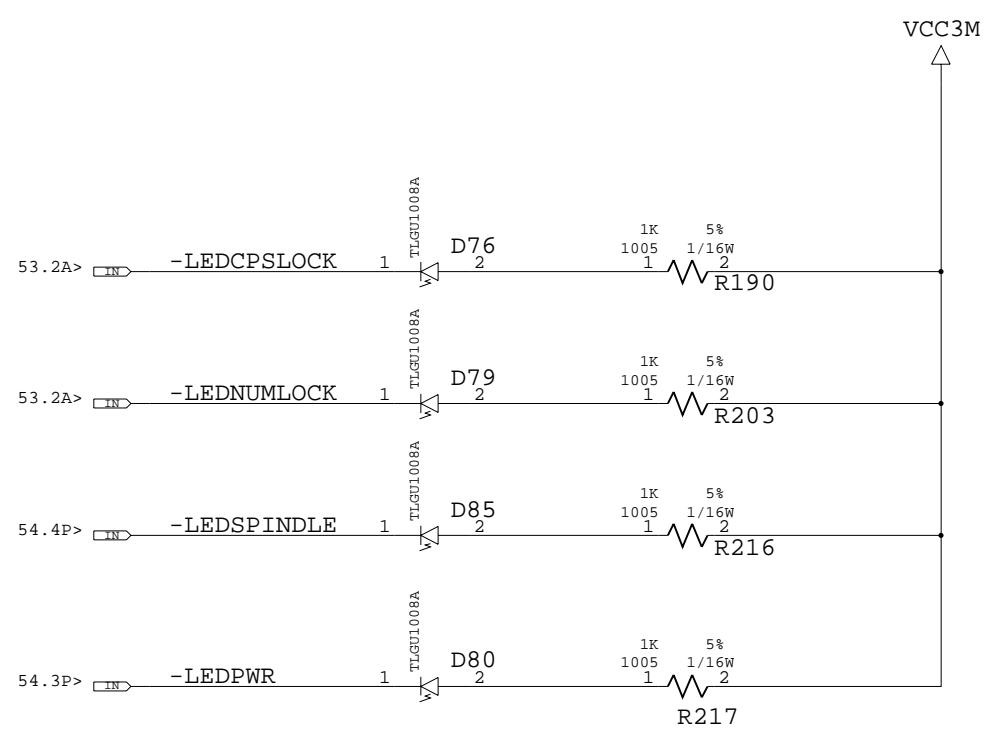

93P4047

DESIGNER	Y.Y	06/12/03	PART NO.	93P4047	
CHECKED	Y.I	06/12/03	TITLE TOKYO-3 SVT(2.00)		
APPROVED	K.T	06/12/03	FAN CONNECTOR AND LED		IBM CONFIDENTIAL
CLASS			THIS DOCUMENT IS THE PROPERTY OF IBM ITS USE IS AUTHORIZED ONLY FOR RESPONDING TO A REQUEST FOR QUOTATION OR FOR THE PERFORMANCE OF WORK FOR IBM. ALL QUESTIONS MUST BE REFERRED TO THE IBM PURCHASING DEPARTMENT.		

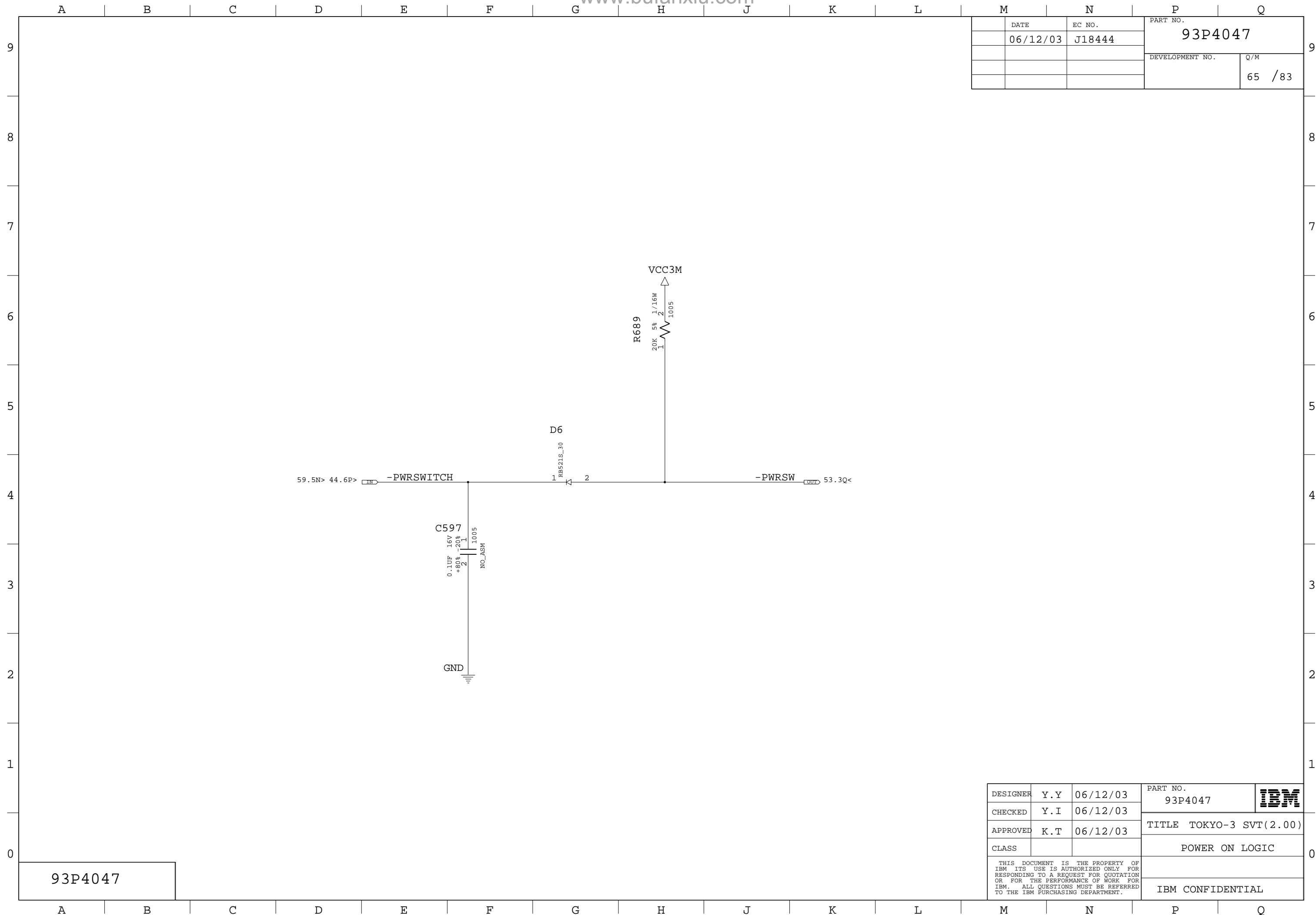

	DATE	EC NO.	PART NO.	
	06/12/03	J18444	93P4047	
			DEVELOPMENT NO.	Q/M
				65 /83

93P4047

DESIGNER	Y.Y	06/12/03	PART NO.	93P4047	IBM
CHECKED	Y.I	06/12/03			
APPROVED	K.T	06/12/03	TITLE TOKYO-3 SVT(2.00)		
CLASS			POWER ON LOGIC		
THIS DOCUMENT IS THE PROPERTY OF IBM ITS USE IS AUTHORIZED ONLY FOR RESPONDING TO A REQUEST FOR QUOTATION OR FOR THE PERFORMANCE OF WORK FOR IBM. ALL QUESTIONS MUST BE REFERRED TO THE IBM PURCHASING DEPARTMENT.				IBM CONFIDENTIAL	

DATE	06/12/03	EC NO.	J18444	PART NO.	93P4047	
DEVELOPMENT NO.		Q/M	66 /83			

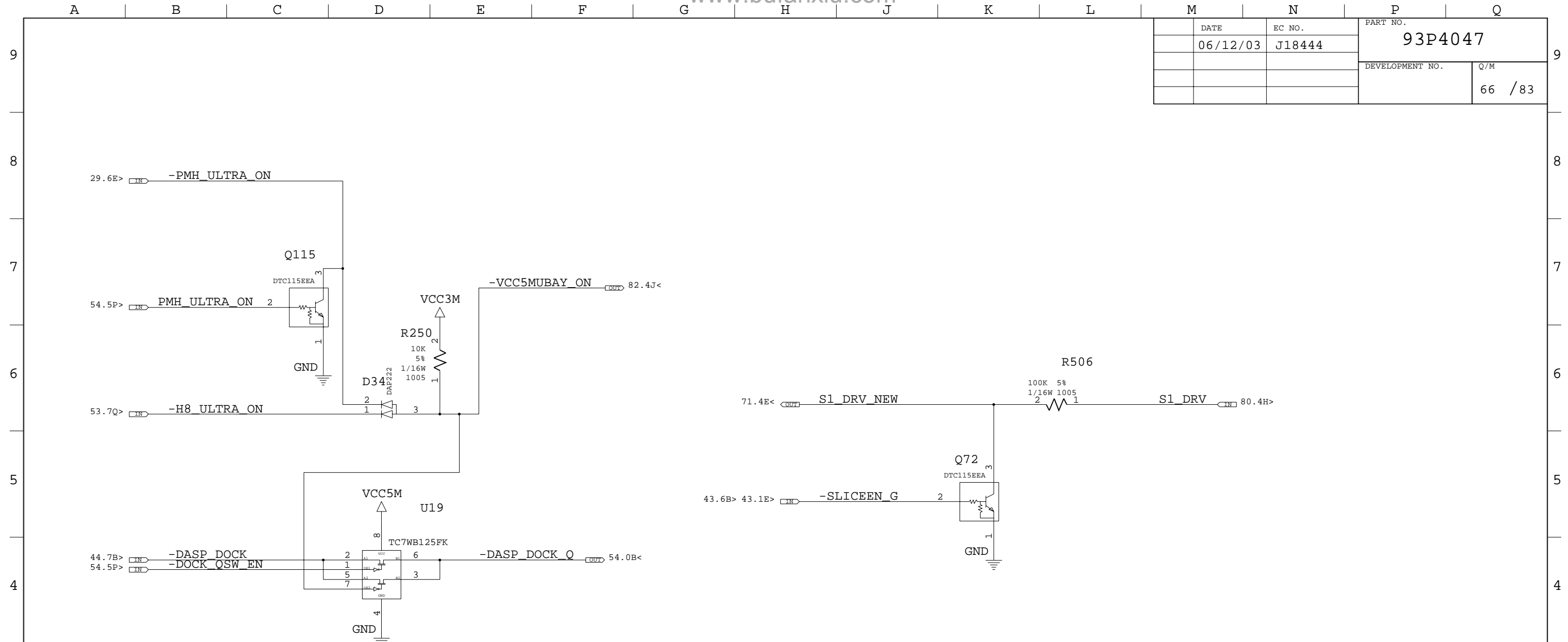

S1_DRV=HIGH	Q7 GATE (FET FOR "S_BAT_PER")	DOCKING INTERFACE 62 PIN (SLICE_ON)
STANDALONE	OFF	LOW
CAIRO	OFF	LOW
MADRID	OFF	LOW
TOKYO-SLICER	ON	HIGH

93P4047

DESIGNER	Y.Y	06/12/03	PART NO.	93P4047	IBM
CHECKED	Y.I	06/12/03	TITLE TOKYO-3 SVT(2.00)		
APPROVED	K.T	06/12/03	SLICE SUPPORT		
CLASS			THIS DOCUMENT IS THE PROPERTY OF IBM ITS USE IS AUTHORIZED ONLY FOR RESPONDING TO A REQUEST FOR QUOTATION OR FOR THE PERFORMANCE OF WORK FOR IBM. ALL QUESTIONS MUST BE REFERRED TO THE IBM PURCHASING DEPARTMENT.		IBM CONFIDENTIAL

KENAI32 : ASM
KINNERETH:NO_ASM

DATE	EC NO.	PART NO.	
06/12/03	J18444	93P4047	
		DEVELOPMENT NO.	Q/M
			67 /83

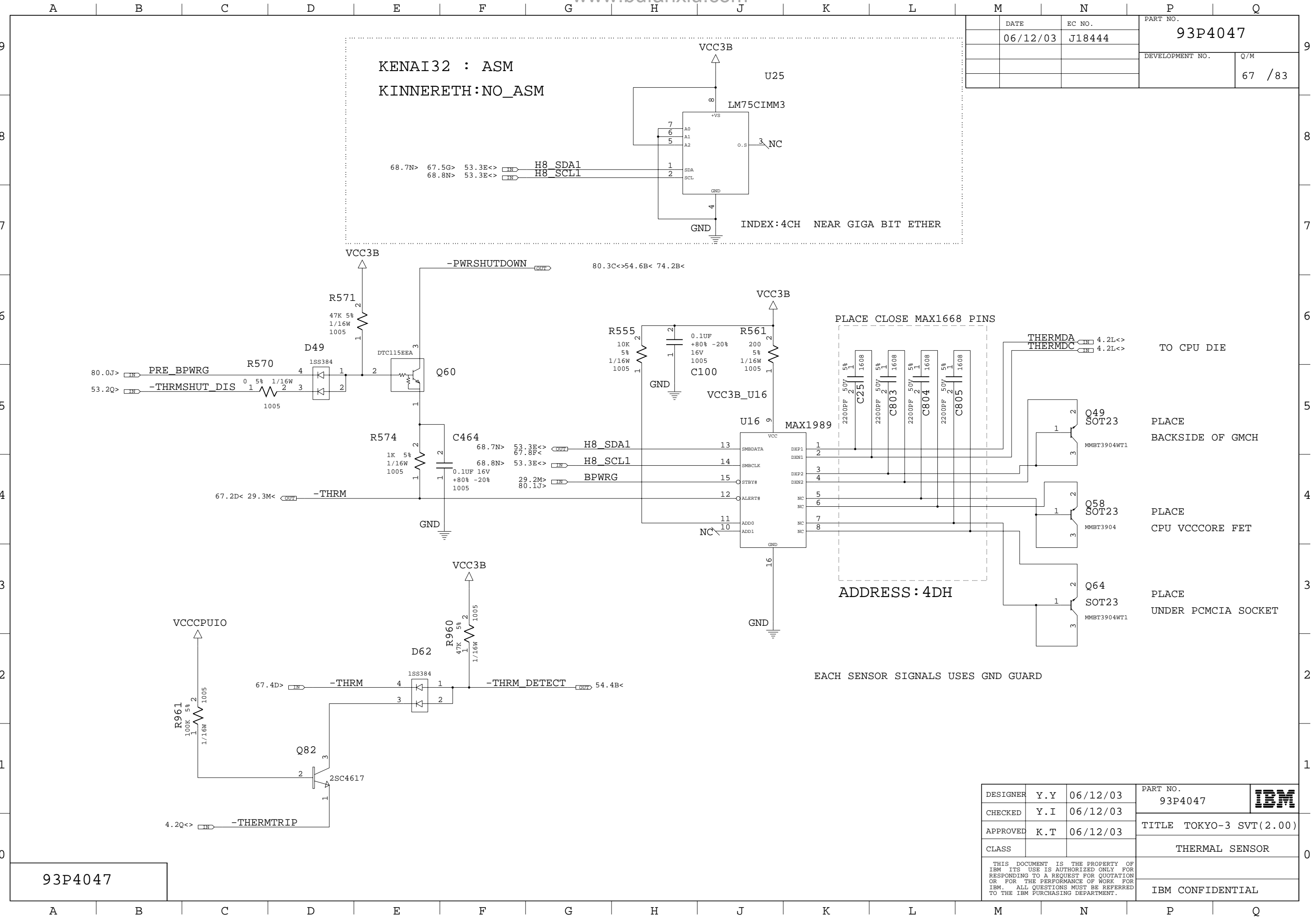

93P4047

DESIGNER	Y.Y	06/12/03	PART NO.	93P4047	
CHECKED	Y.I	06/12/03	TITLE TOKYO-3 SVT(2.00)		
APPROVED	K.T	06/12/03	THERMAL SENSOR		
CLASS			IBM CONFIDENTIAL		

THIS DOCUMENT IS THE PROPERTY OF IBM ITS USE IS AUTHORIZED ONLY FOR RESPONDING TO A REQUEST FOR QUOTATION OR FOR THE PERFORMANCE OF WORK FOR IBM. ALL QUESTIONS MUST BE REFERRED TO THE IBM PURCHASING DEPARTMENT.

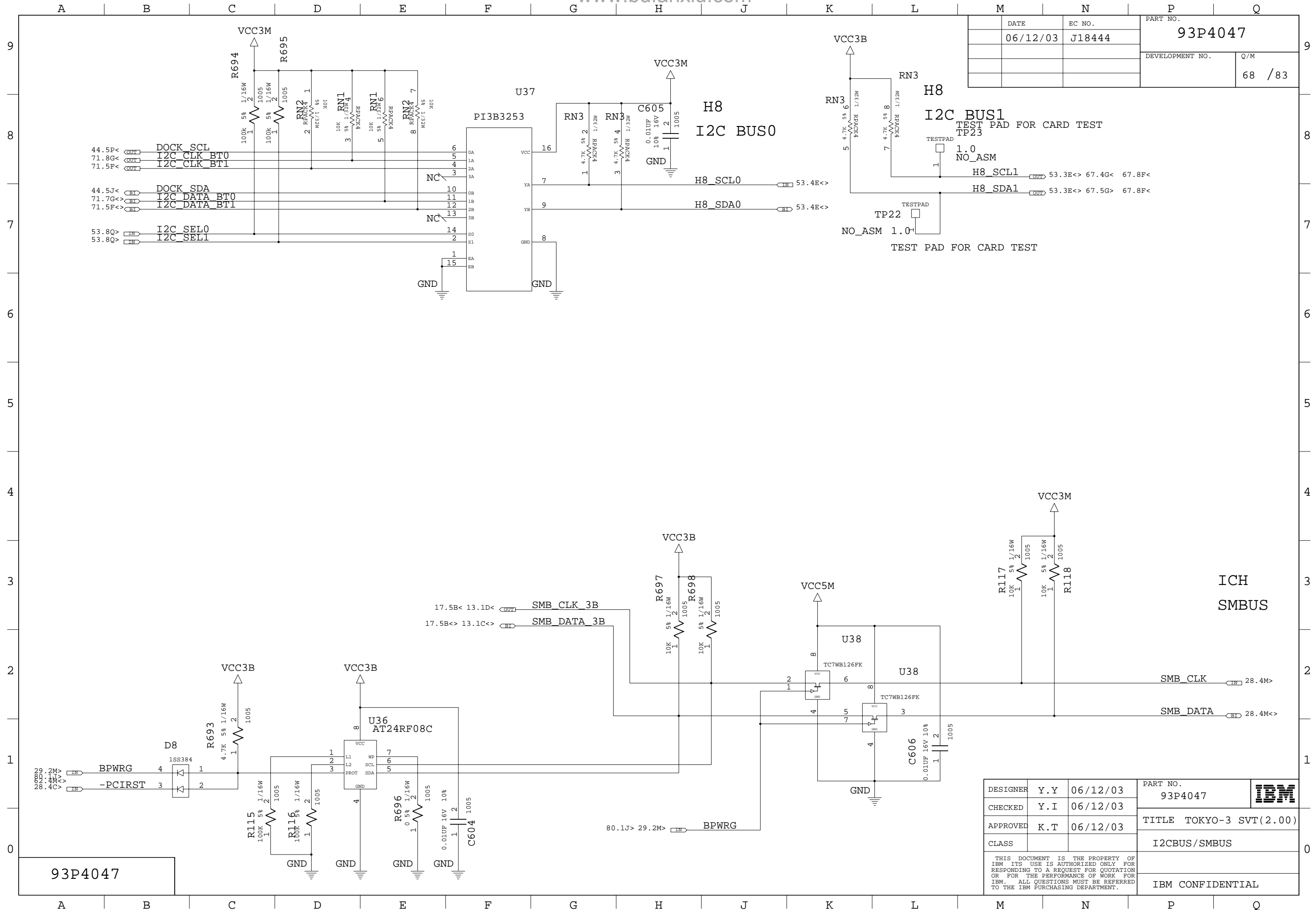

DATE	EC NO.	PART NO.
06/12/03	J18444	93P4047
		DEVELOPMENT NO.
		Q/M
		68 / 83

DESIGNER	Y.Y	06/12/03	PART NO.	93P4047	
CHECKED	Y.I	06/12/03	TITLE TOKYO-3 SVT(2.00)		
APPROVED	K.T	06/12/03	I2CBUS/SMBUS		
CLASS			THIS DOCUMENT IS THE PROPERTY OF IBM ITS USE IS AUTHORIZED ONLY FOR RESPONDING TO A REQUEST FOR QUOTATION OR FOR THE PERFORMANCE OF WORK FOR IBM. ALL QUESTIONS MUST BE REFERRED TO THE IBM PURCHASING DEPARTMENT.		IBM CONFIDENTIAL

93P4047

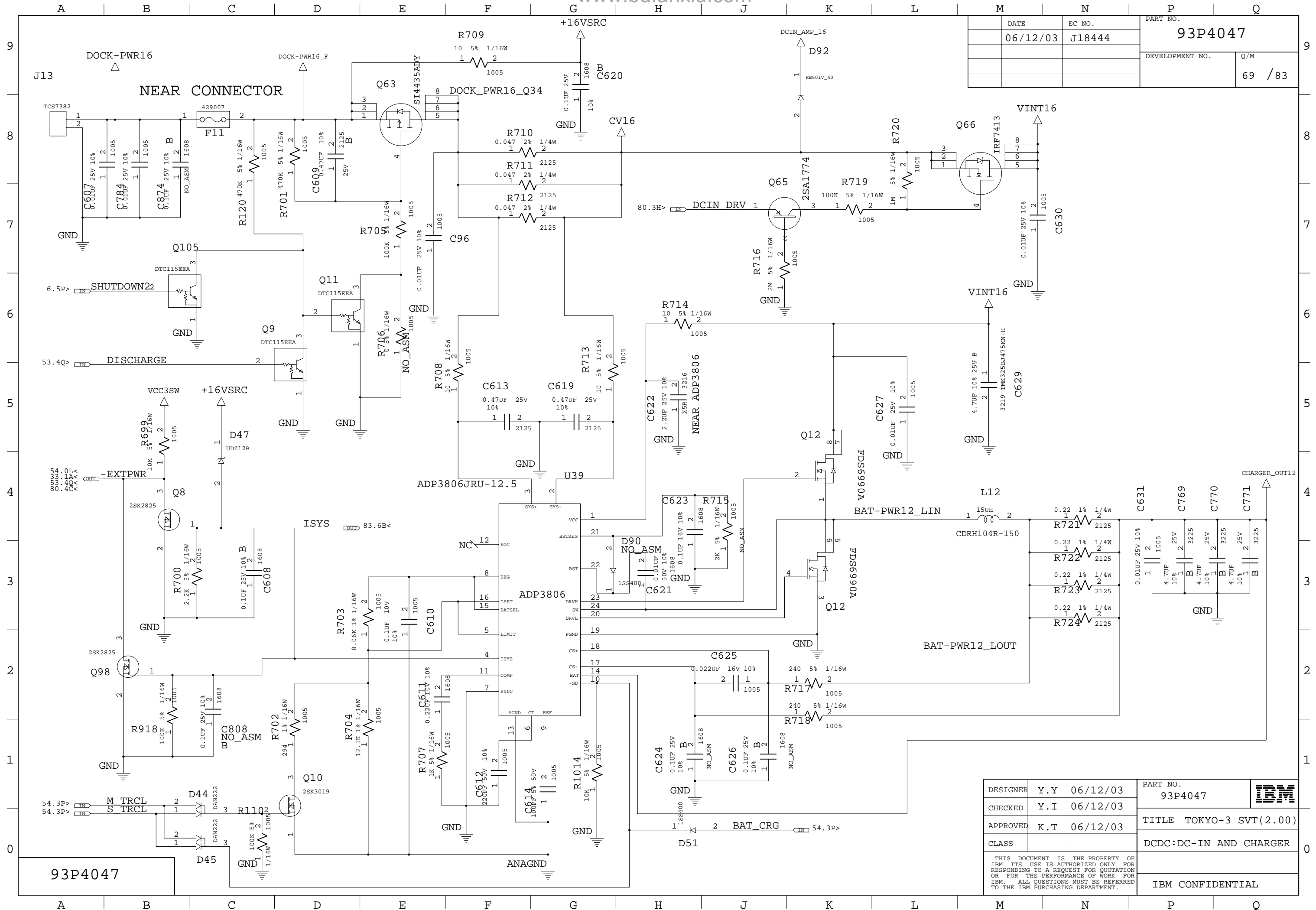

DATE	EC NO.	PART NO.
06/12/03	J18444	93P4047
DEVELOPMENT NO.		Q/M
		69 / 83

93P4047

DESIGNER	Y.Y	06/12/03	PART NO.	93P4047	
CHECKED	Y.I	06/12/03	TITLE TOKYO-3 SVT(2.00)		
APPROVED	K.T	06/12/03	DCDC:DC-IN AND CHARGER		
CLASS					IBM CONFIDENTIAL

THIS DOCUMENT IS THE PROPERTY OF IBM ITS USE IS AUTHORIZED ONLY FOR RESPONDING TO A REQUEST FOR QUOTATION OR FOR THE PERFORMANCE OF WORK FOR IBM. ALL QUESTIONS MUST BE REFERRED TO THE IBM PURCHASING DEPARTMENT.

	DATE	EC NO.	PART NO.	
	06/12/03	J18444	93P4047	
			DEVELOPMENT NO.	Q/M
				70 / 83

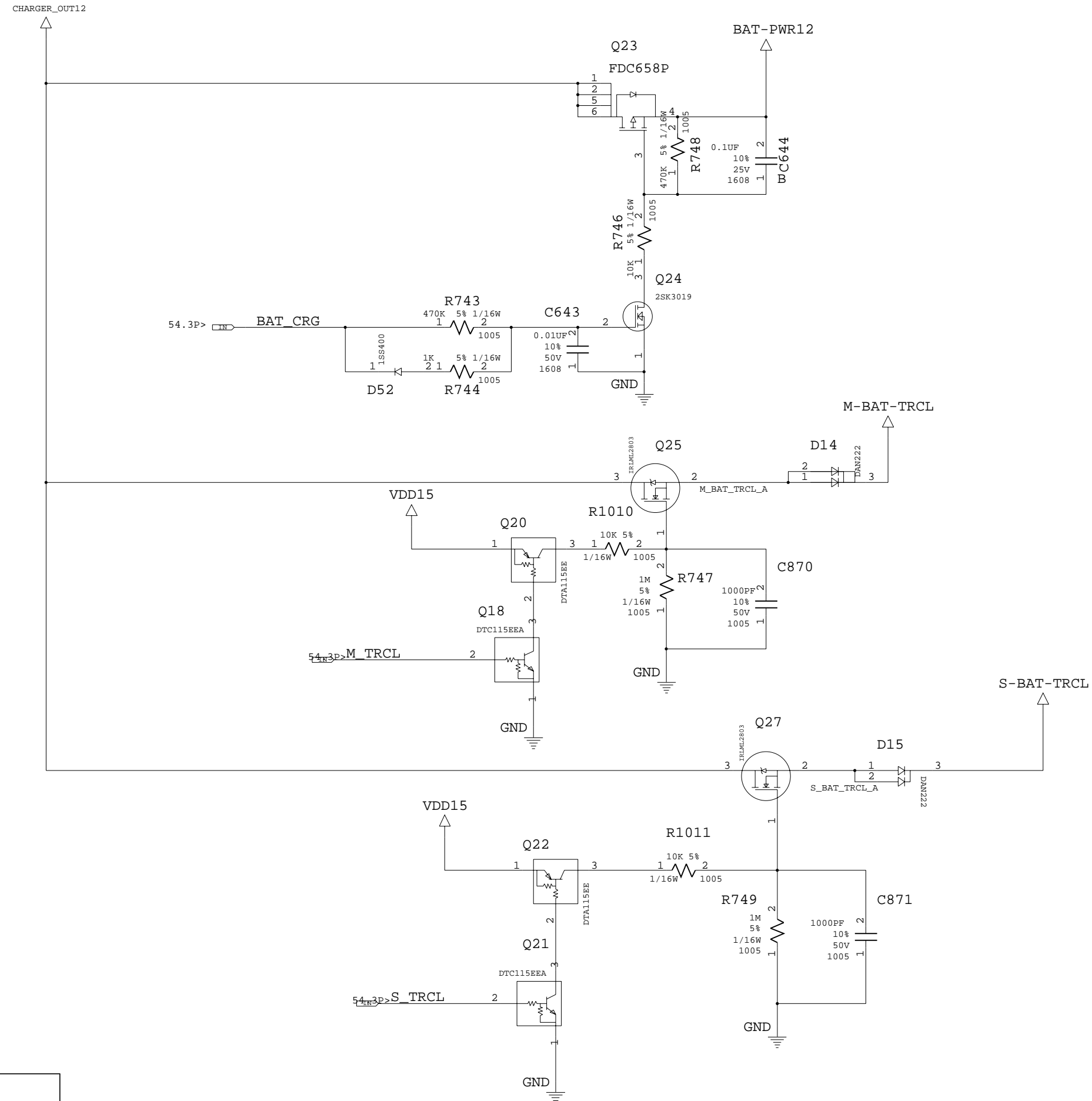

93P4047

DESIGNER	Y.Y	06/12/03	PART NO.	93P4047	
CHECKED	Y.I	06/12/03	TITLE TOKYO-3 SVT(2.00)		
APPROVED	K.T	06/12/03	CLASS		DCDC:CHARGER SELECT
THIS DOCUMENT IS THE PROPERTY OF IBM ITS USE IS AUTHORIZED ONLY FOR RESPONDING TO A REQUEST FOR QUOTATION OR FOR THE PERFORMANCE OF WORK FOR IBM. ALL QUESTIONS MUST BE REFERRED TO THE IBM PURCHASING DEPARTMENT.					IBM CONFIDENTIAL

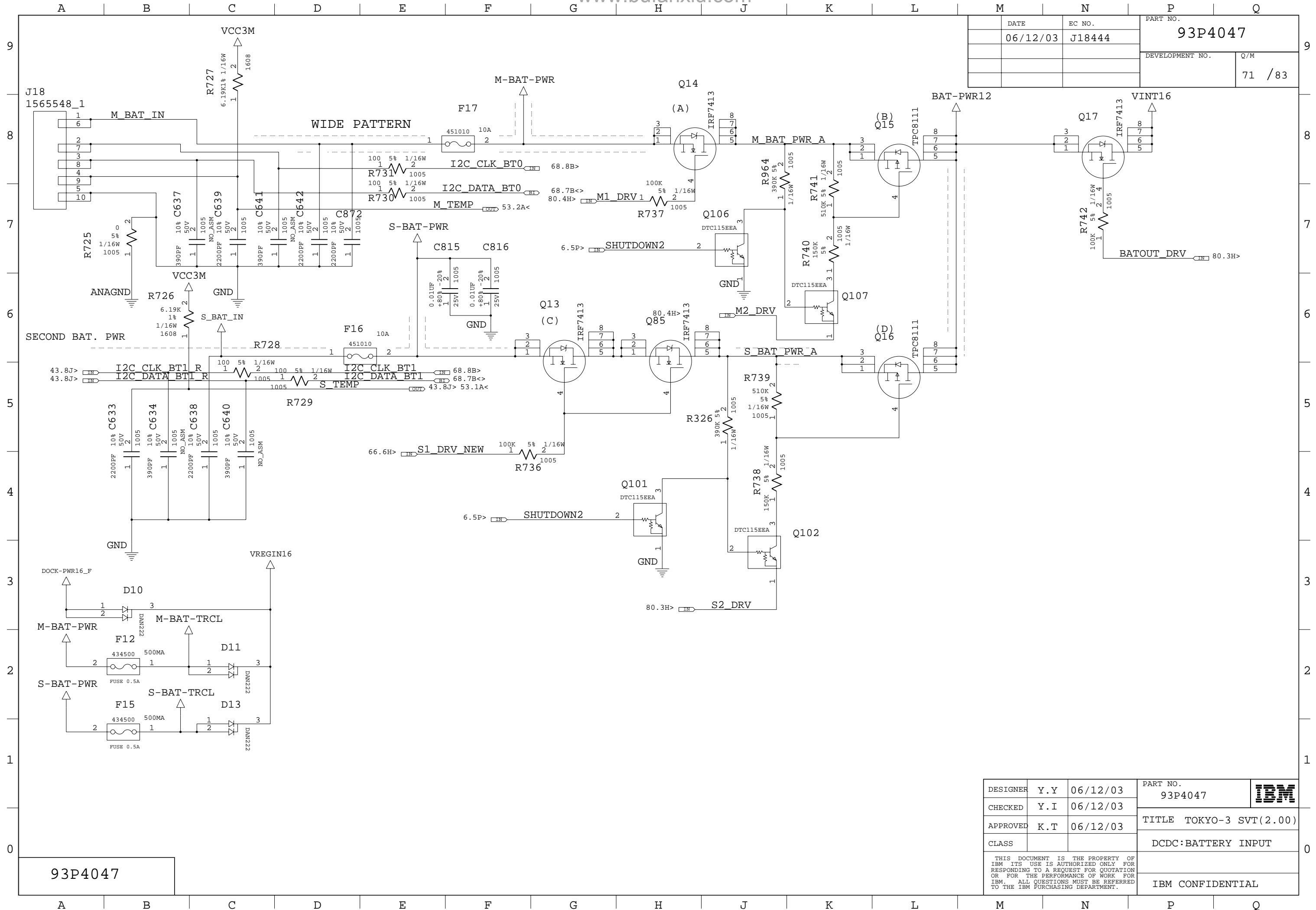

DATE	EC NO.	PART NO.
06/12/03	J18444	93P4047
DEVELOPMENT NO.		Q/M
		71 / 83

93P4047

DESIGNER	Y.Y	06/12/03	PART NO.	93P4047	
CHECKED	Y.I	06/12/03	TITLE TOKYO-3 SVT(2.00)		
APPROVED	K.T	06/12/03	DCDC: BATTERY INPUT		
CLASS			IBM CONFIDENTIAL		

THIS DOCUMENT IS THE PROPERTY OF IBM ITS USE IS AUTHORIZED ONLY FOR RESPONDING TO A REQUEST FOR QUOTATION OR FOR THE PERFORMANCE OF WORK FOR IBM. ALL QUESTIONS MUST BE REFERRED TO THE IBM PURCHASING DEPARTMENT.

	DATE	EC NO.	PART NO.	
	06/12/03	J18444	93P4047	
			DEVELOPMENT NO.	Q/M
				72 / 83

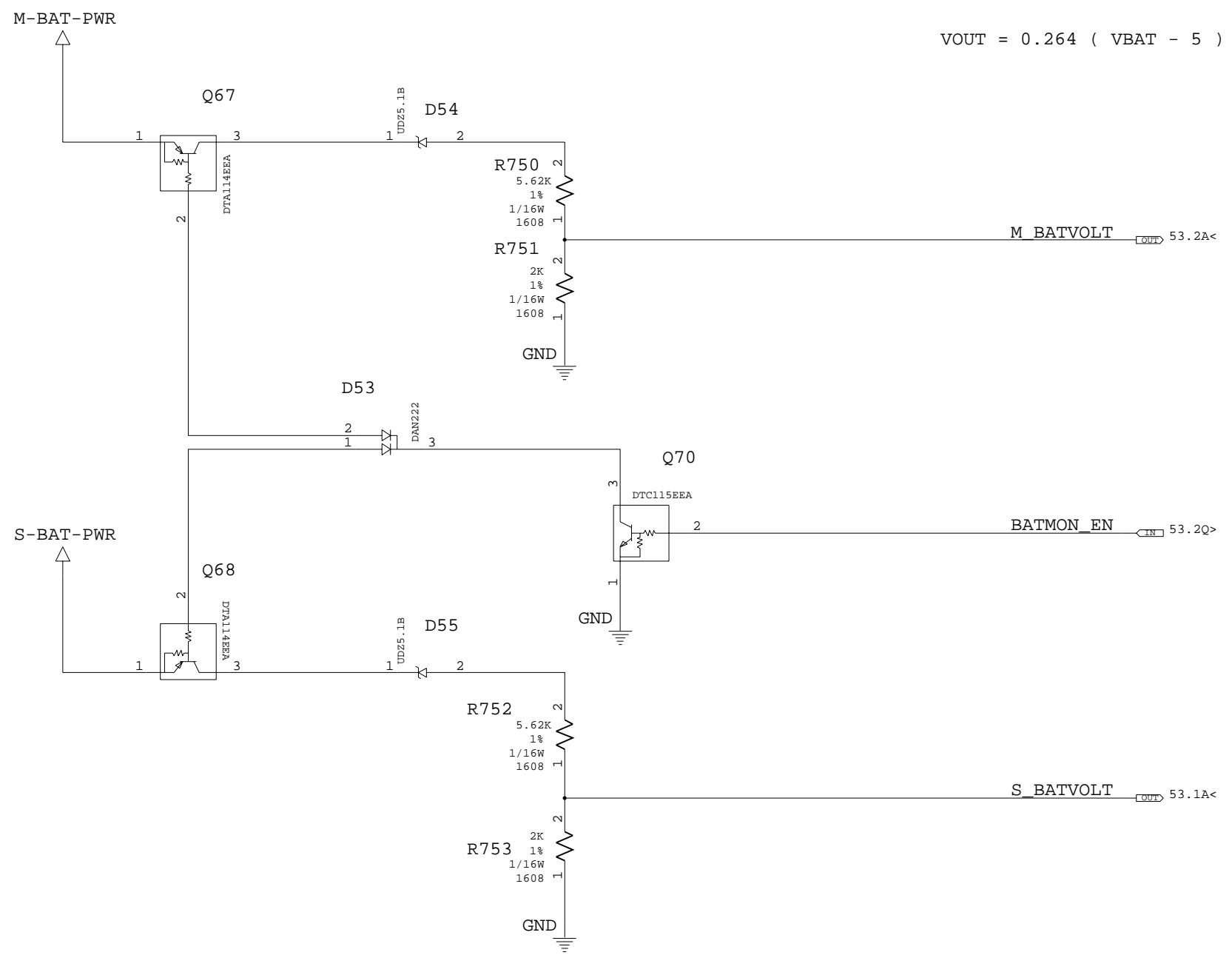

93P4047

DESIGNER	Y.Y	06/12/03	PART NO.	93P4047	IBM
CHECKED	Y.I	06/12/03	TITLE		
APPROVED	K.T	06/12/03	CLASS	DCDC:BATTERY MONITOR	
THIS DOCUMENT IS THE PROPERTY OF IBM ITS USE IS AUTHORIZED ONLY FOR RESPONDING TO A REQUEST FOR QUOTATION OR FOR THE PERFORMANCE OF WORK FOR IBM. ALL QUESTIONS MUST BE REFERRED TO THE IBM PURCHASING DEPARTMENT.				IBM CONFIDENTIAL	

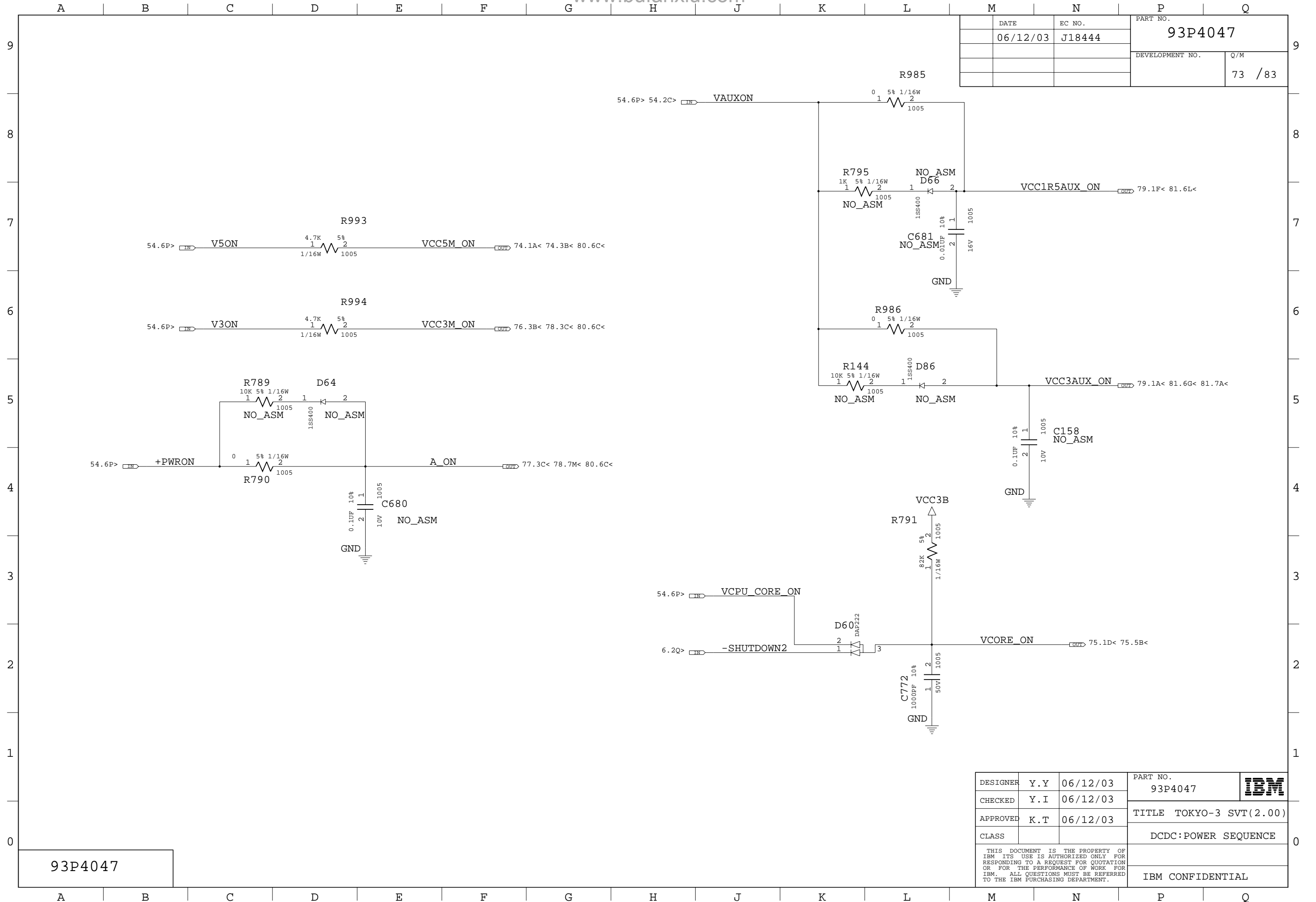

DATE	EC NO.	PART NO.	
06/12/03	J18444	93P4047	
		DEVELOPMENT NO.	Q/M
			73 / 83

93P4047

DESIGNER	Y.Y	06/12/03	PART NO.	93P4047	IBM
CHECKED	Y.I	06/12/03			
APPROVED	K.T	06/12/03	TITLE TOKYO-3 SVT(2.00)		
CLASS			DCDC:POWER SEQUENCE		
THIS DOCUMENT IS THE PROPERTY OF IBM ITS USE IS AUTHORIZED ONLY FOR RESPONDING TO A REQUEST FOR QUOTATION OR FOR THE PERFORMANCE OF WORK FOR IBM. ALL QUESTIONS MUST BE REFERRED TO THE IBM PURCHASING DEPARTMENT.					IBM CONFIDENTIAL

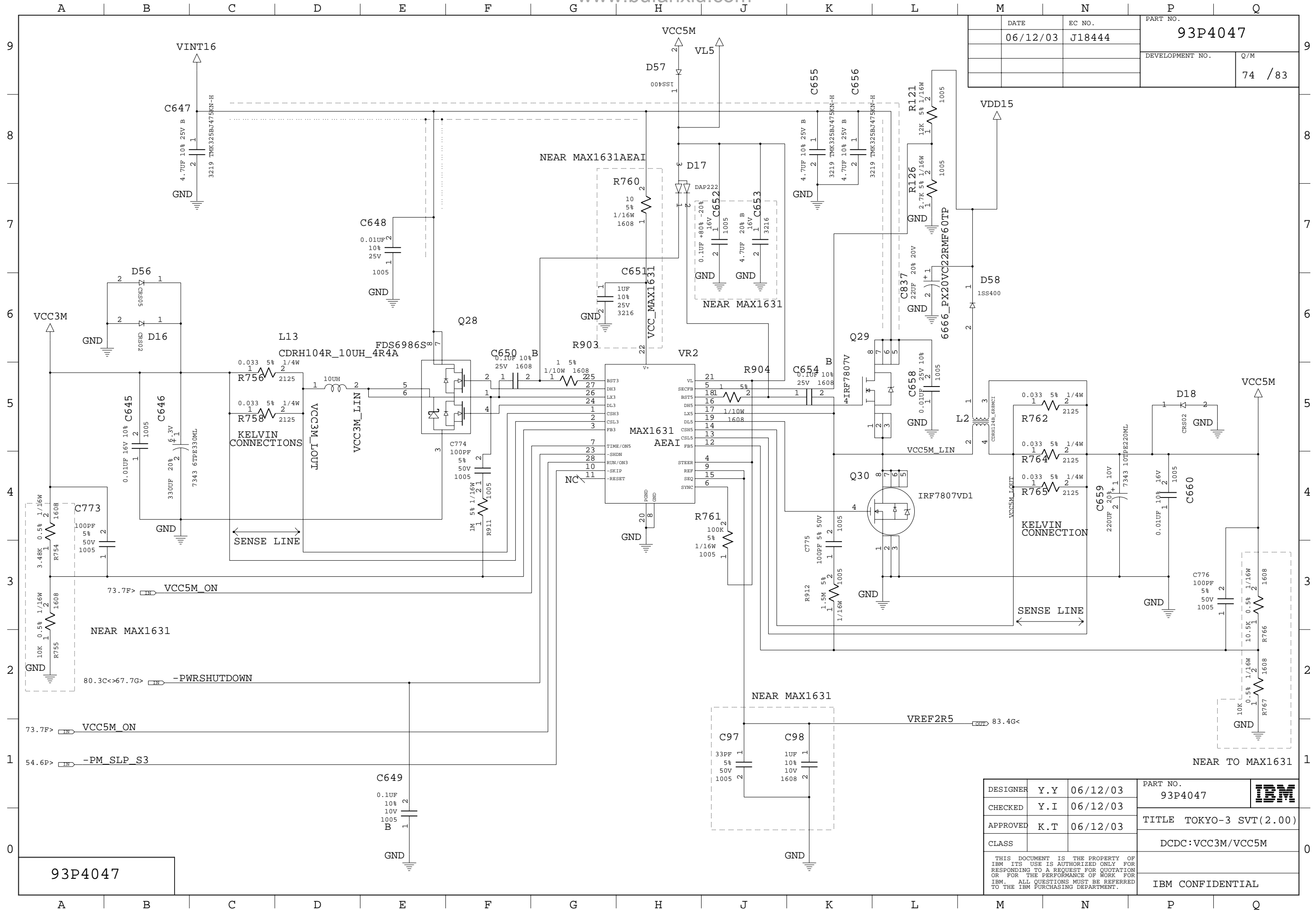

DATE	EC NO.	PART NO.
06/12/03	J18444	93P4047
DEVELOPMENT NO.		Q/M
		74 / 83

93P4047

DESIGNER	Y.Y	06/12/03	PART NO.	93P4047	
CHECKED	Y.I	06/12/03	TITLE TOKYO-3 SVT(2.00)		
APPROVED	K.T	06/12/03	CLASS DCDC:VCC3M/VCC5M		
THIS DOCUMENT IS THE PROPERTY OF IBM ITS USE IS AUTHORIZED ONLY FOR RESPONDING TO A REQUEST FOR QUOTATION OR FOR THE PERFORMANCE OF WORK FOR IBM. ALL QUESTIONS MUST BE REFERRED TO THE IBM PURCHASING DEPARTMENT.					IBM CONFIDENTIAL

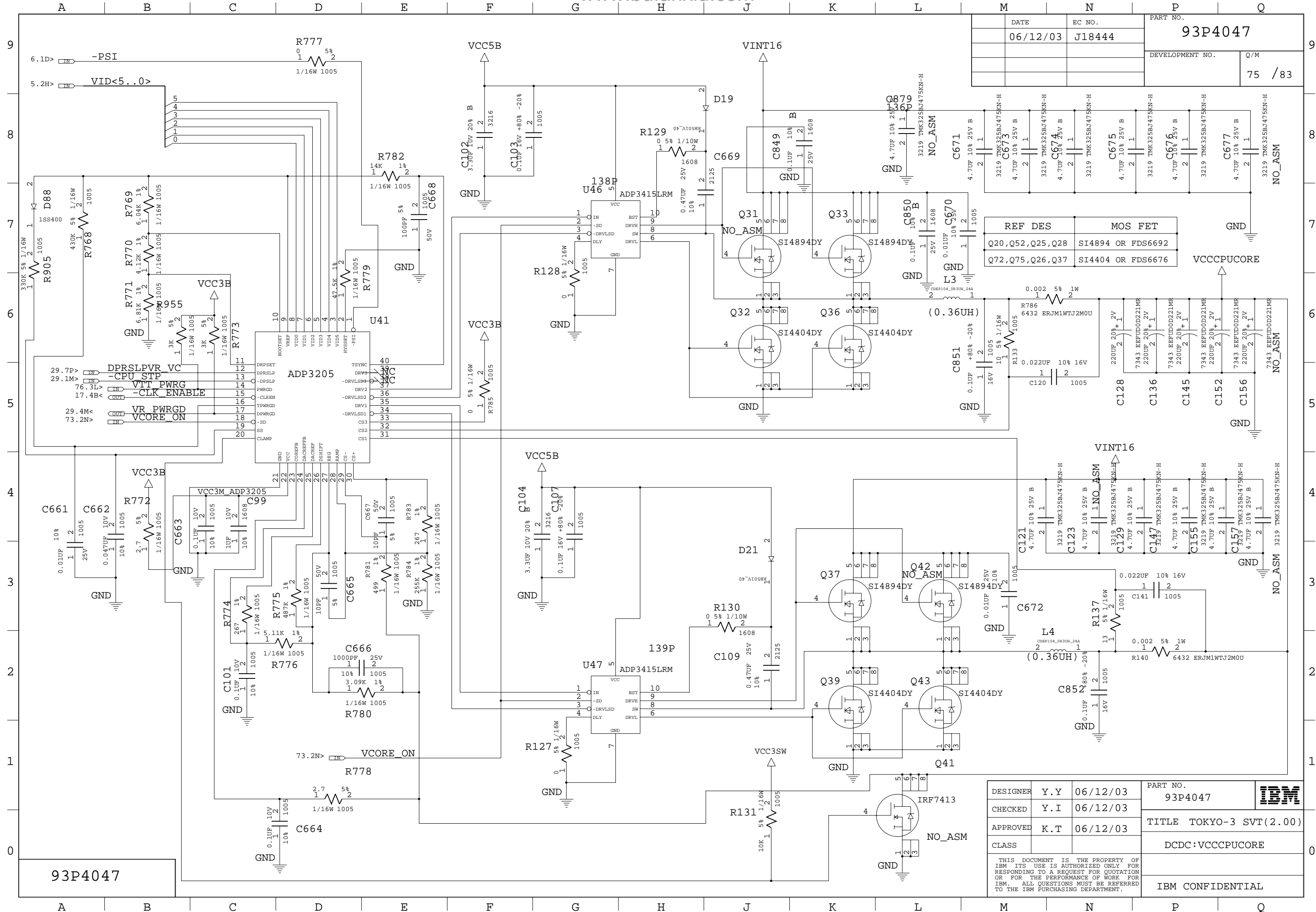

DATE	EC NO.	PART NO.
06/12/03	J18444	93P4047
DEVELOPMENT NO.		Q/M
		75 / 83

REF DES	MOS FET
Q20,Q52,Q25,Q28	SI4894 OR FDS6692
Q72,Q75,Q26,Q37	SI4404 OR FDS6676

DESIGNER	Y.Y	06/12/03	PART NO.	93P4047	
CHECKED	Y.I	06/12/03	TITLE TOKYO-3 SVT(2.00)		
APPROVED	K.T	06/12/03	CLASS DCDC:VCCPUCORE		
THIS DOCUMENT IS THE PROPERTY OF IBM ITS USE IS AUTHORIZED ONLY FOR RESPONDING TO A REQUEST FOR QUOTATION OR FOR THE PERFORMANCE OF WORK FOR IBM. ALL QUESTIONS MUST BE REFERRED TO THE IBM PURCHASING DEPARTMENT.				IBM CONFIDENTIAL	

93P4047

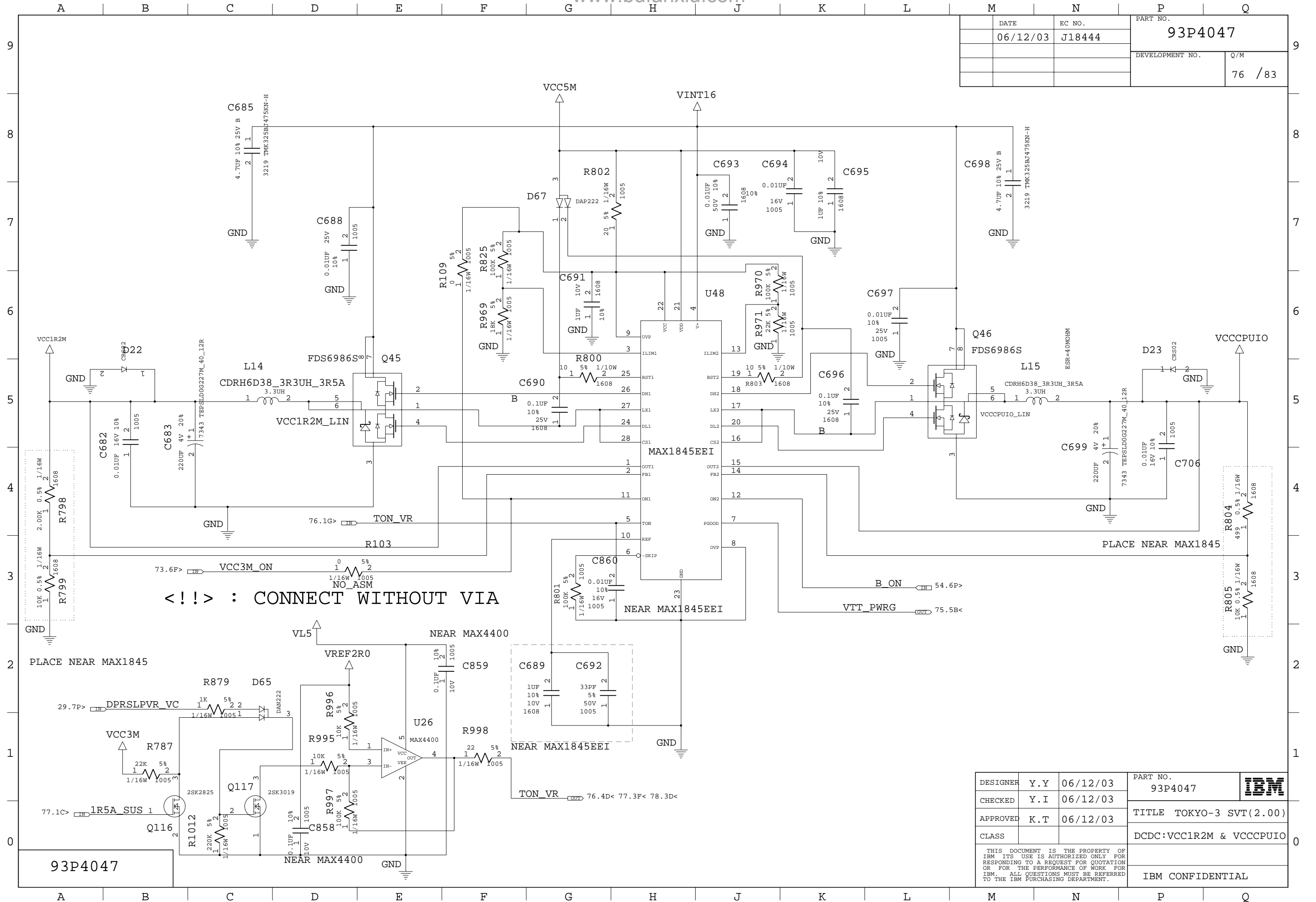

DATE	EC NO.	PART NO.	
06/12/03	J18444	93P4047	
		DEVELOPMENT NO.	Q/M
			76 / 83

<!!!> : CONNECT WITHOUT VIA

DESIGNER	Y.Y	06/12/03	PART NO.	93P4047	
CHECKED	Y.I	06/12/03	TITLE TOKYO-3 SVT(2.00)		
APPROVED	K.T	06/12/03	CLASS		DCDC:VCC1R2M & VCCCPUIO
THIS DOCUMENT IS THE PROPERTY OF IBM ITS USE IS AUTHORIZED ONLY FOR RESPONDING TO A REQUEST FOR QUOTATION OR FOR THE PERFORMANCE OF WORK FOR IBM. ALL QUESTIONS MUST BE REFERRED TO THE IBM PURCHASING DEPARTMENT.					IBM CONFIDENTIAL

93P4047

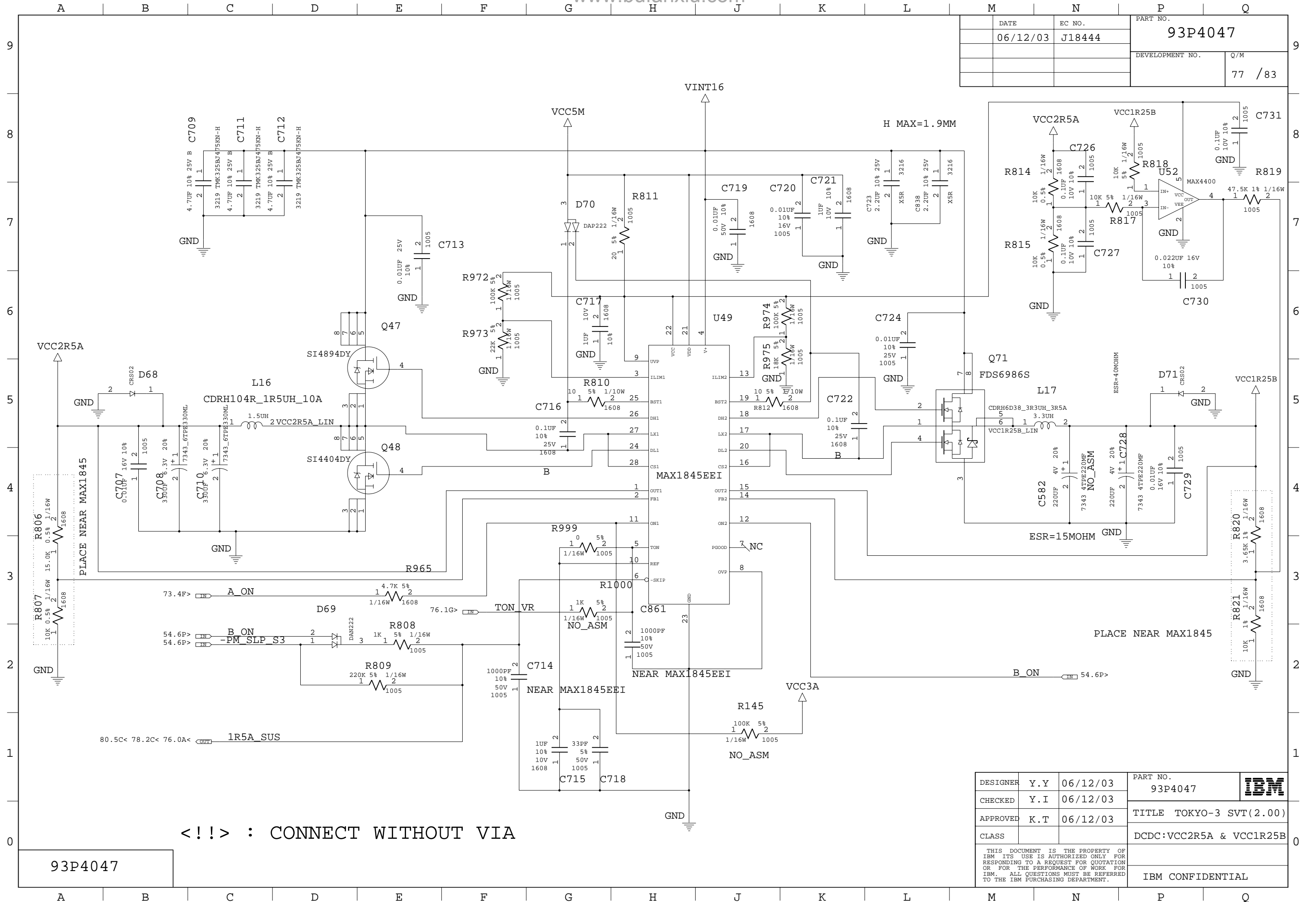

DATE	EC NO.	PART NO.
06/12/03	J18444	93P4047
DEVELOPMENT NO.		Q/M
		77 / 83

DESIGNER	Y.Y	06/12/03	PART NO.	93P4047	IBM
CHECKED	Y.I	06/12/03	TITLE TOKYO-3 SVT(2.00)		
APPROVED	K.T	06/12/03	CLASS		DCDC:VCC2R5A & VCC1R25B
THIS DOCUMENT IS THE PROPERTY OF IBM ITS USE IS AUTHORIZED ONLY FOR RESPONDING TO A REQUEST FOR QUOTATION OR FOR THE PERFORMANCE OF WORK FOR IBM. ALL QUESTIONS MUST BE REFERRED TO THE IBM PURCHASING DEPARTMENT.					IBM CONFIDENTIAL

93P4047

<!!!> : CONNECT WITHOUT VIA

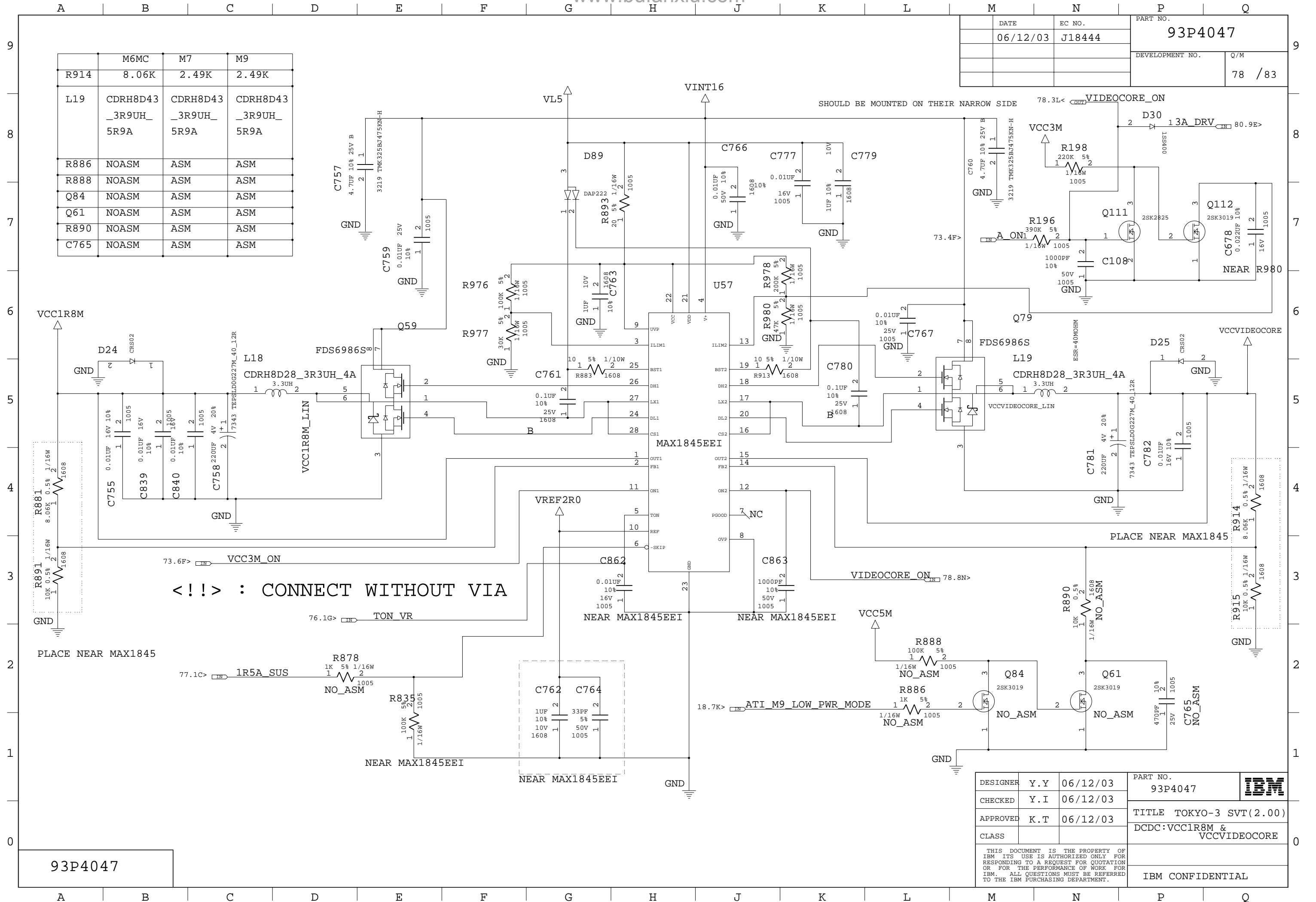

<!!> : CONNECT WITHOUT VIA

93P4047

DESIGNER	Y.Y	06/12/03	PART NO.	93P4047	
CHECKED	Y.I	06/12/03	TITLE TOKYO-3 SVT(2.00)		
APPROVED	K.T	06/12/03	DCDC:VCC1R8M & VCCVIDEOCORE		
CLASS			IBM CONFIDENTIAL		

THIS DOCUMENT IS THE PROPERTY OF IBM ITS USE IS AUTHORIZED ONLY FOR RESPONDING TO A REQUEST FOR QUOTATION OR FOR THE PERFORMANCE OF WORK FOR IBM. ALL QUESTIONS MUST BE REFERRED TO THE IBM PURCHASING DEPARTMENT.

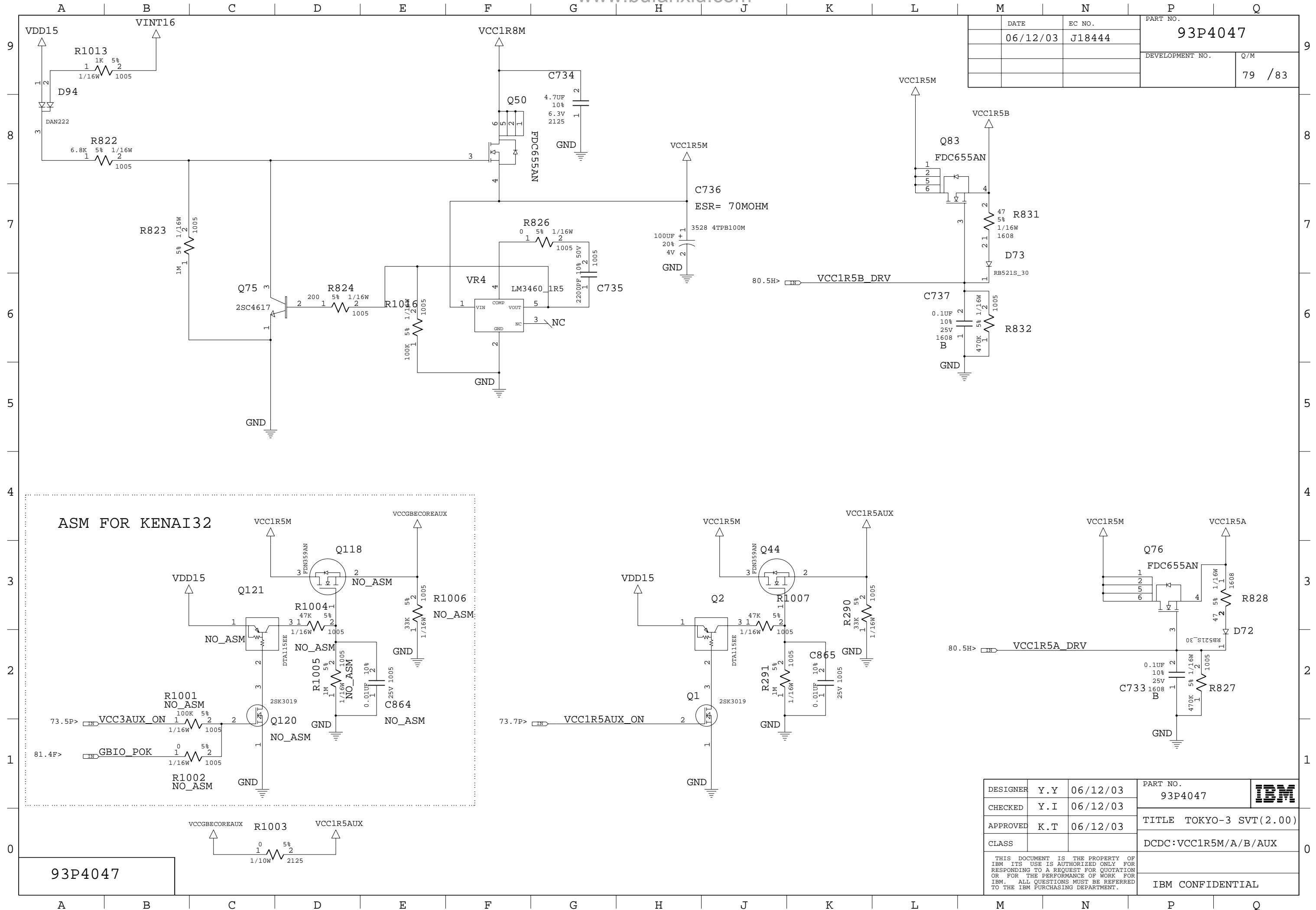

DATE	EC NO.	PART NO.
06/12/03	J18444	93P4047
DEVELOPMENT NO.		Q/M
		79 /83

DESIGNER	Y.Y	06/12/03	PART NO.	93P4047	IBM
CHECKED	Y.I	06/12/03	TITLE TOKYO-3 SVT(2.00)		
APPROVED	K.T	06/12/03	CLASS DCDC:VCC1R5M/A/B/AUX		
THIS DOCUMENT IS THE PROPERTY OF IBM ITS USE IS AUTHORIZED ONLY FOR RESPONDING TO A REQUEST FOR QUOTATION OR FOR THE PERFORMANCE OF WORK FOR IBM. ALL QUESTIONS MUST BE REFERRED TO THE IBM PURCHASING DEPARTMENT.					IBM CONFIDENTIAL

93P4047

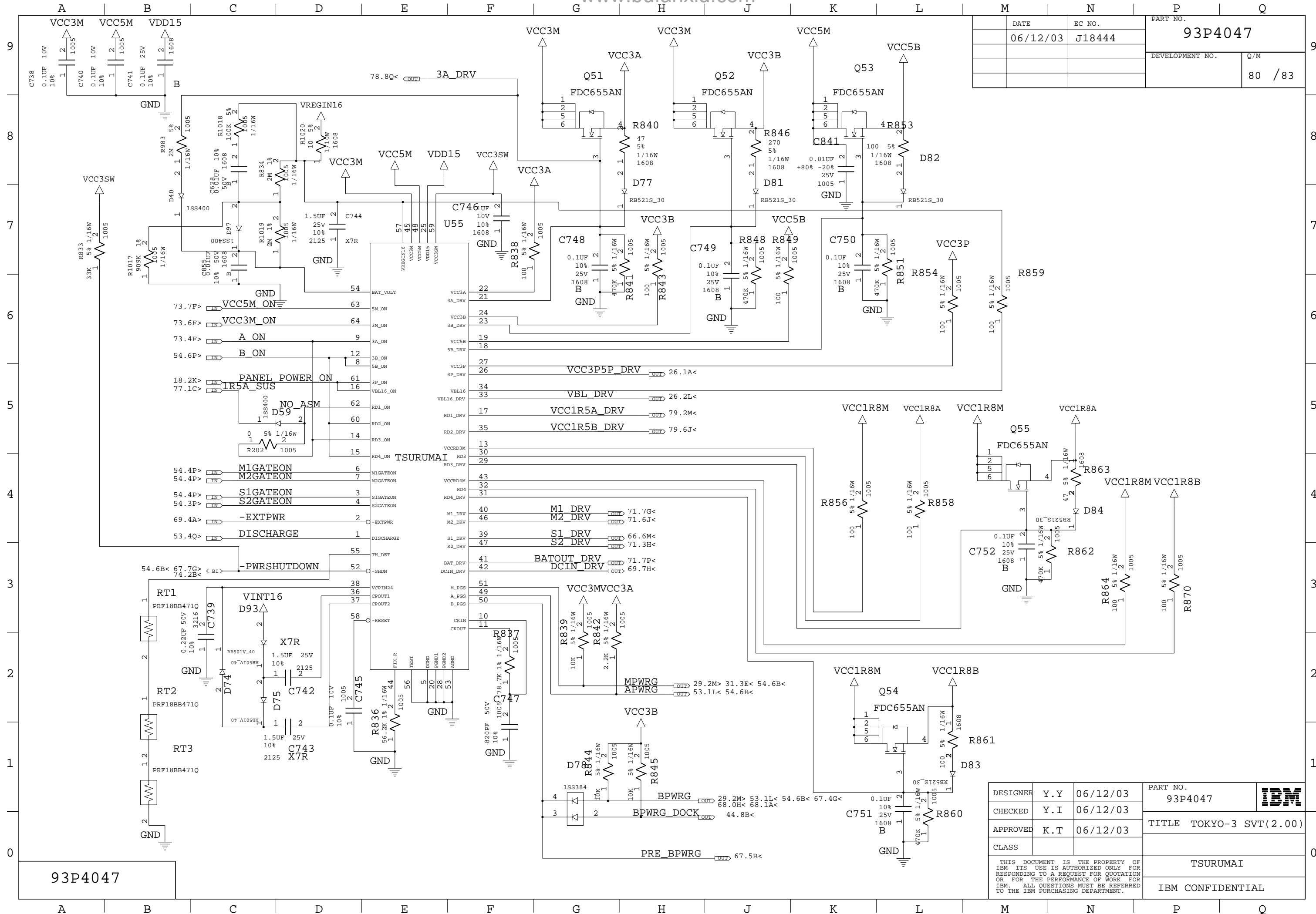

DATE	EC NO.	PART NO.
06/12/03	J18444	93P4047
DEVELOPMENT NO.		Q/M
		80 / 83

93P4047

DESIGNER	Y.Y	06/12/03	PART NO.	93P4047	
CHECKED	Y.I	06/12/03	TITLE TOKYO-3 SVT(2.00)		
APPROVED	K.T	06/12/03			
CLASS			TSURUMAI		
THIS DOCUMENT IS THE PROPERTY OF IBM ITS USE IS AUTHORIZED ONLY FOR RESPONDING TO A REQUEST FOR QUOTATION OR FOR THE PERFORMANCE OF WORK FOR IBM. ALL QUESTIONS MUST BE REFERRED TO THE IBM PURCHASING DEPARTMENT.					IBM CONFIDENTIAL

DATE	EC NO.	PART NO.
06/12/03	J18444	93P4047
DEVELOPMENT NO.		Q/M
		81 / 83

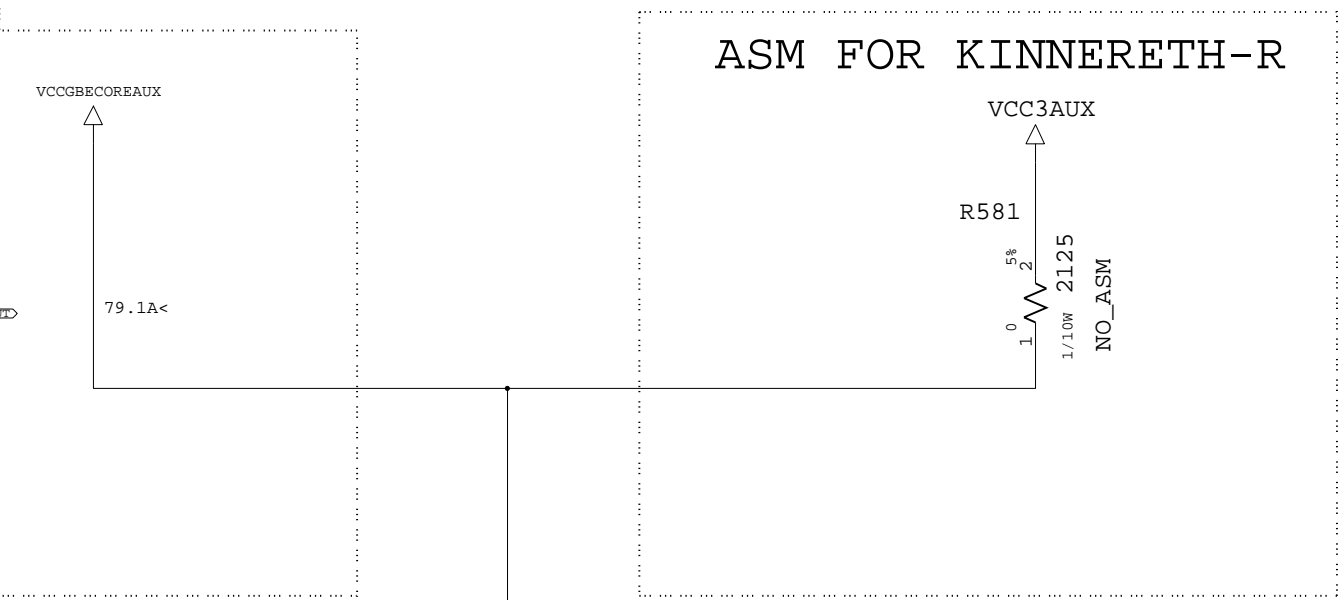
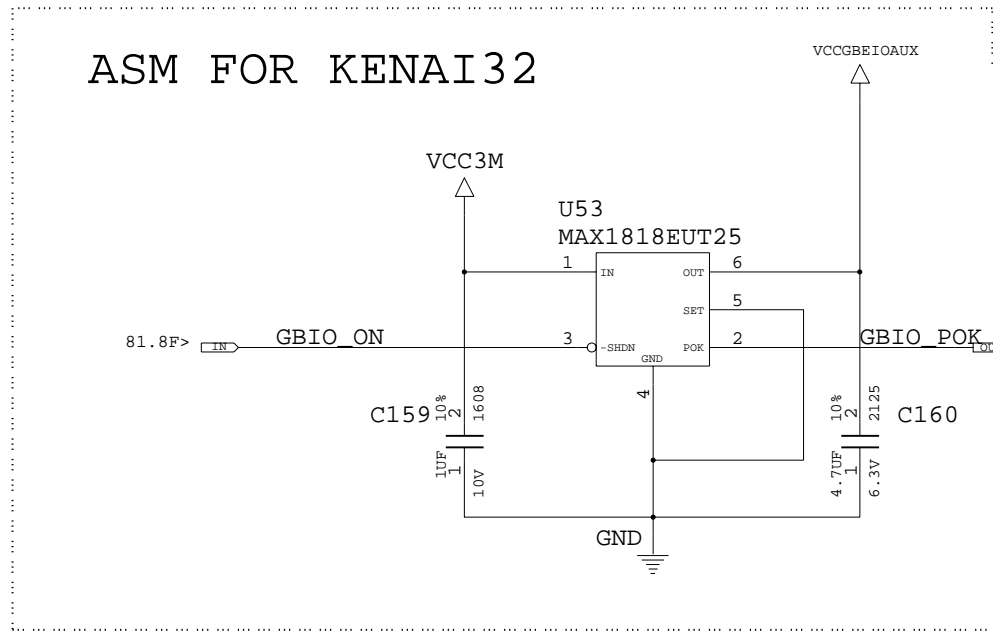
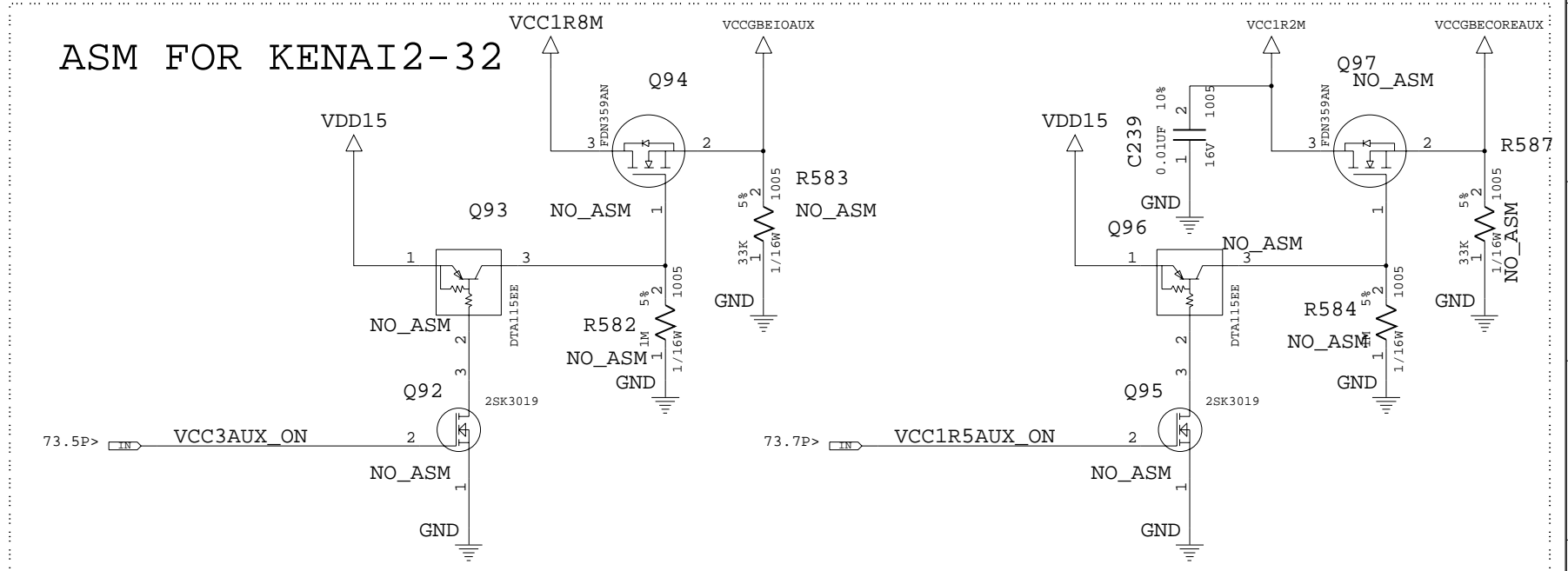
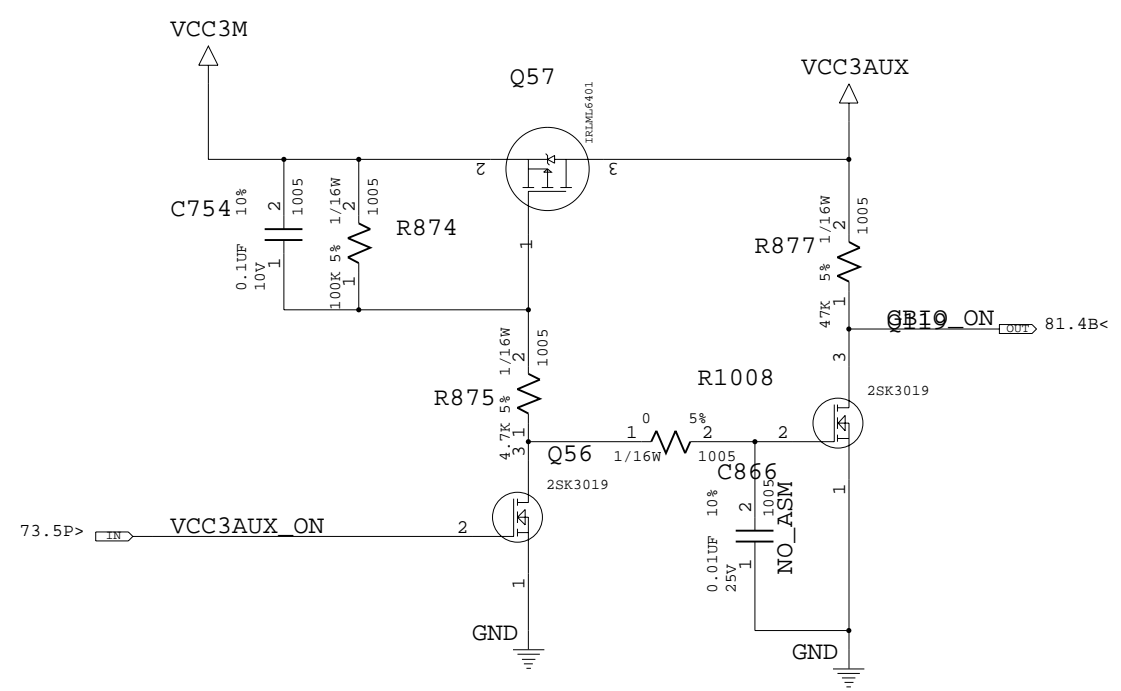

	KENAI32	KENAI2-32	KINNERETH-R
VCCGBECOREAUX	1.5V	1.2V	3.3V
VCCGBEIOAUX	2.5V	1.8V	N.C.

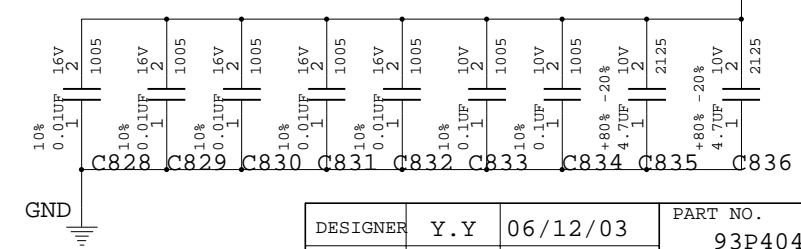
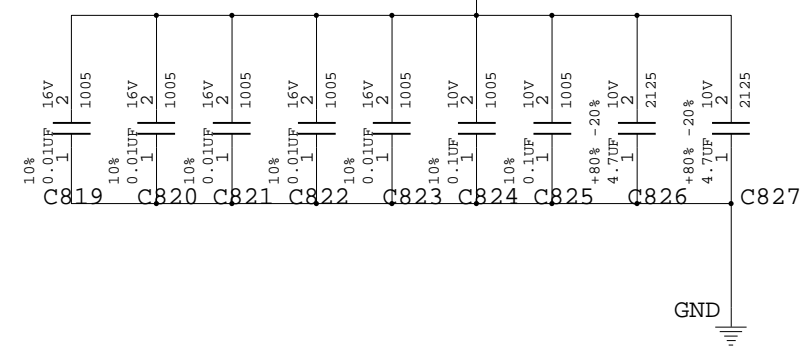

DESIGNER	Y.Y	06/12/03	PART NO.	93P4047	
CHECKED	Y.I	06/12/03	TITLE TOKYO-3 SVT(2.00)		
APPROVED	K.T	06/12/03	DCDC:VCC FOR GIGABIT ETHER		IBM CONFIDENTIAL
CLASS			THIS DOCUMENT IS THE PROPERTY OF IBM ITS USE IS AUTHORIZED ONLY FOR RESPONDING TO A REQUEST FOR QUOTATION OR FOR THE PERFORMANCE OF WORK FOR IBM. ALL QUESTIONS MUST BE REFERRED TO THE IBM PURCHASING DEPARTMENT.		

93P4047

DATE	06/12/03	EC NO.	J18444	PART NO.	93P4047	
DEVELOPMENT NO.			Q/M			
			82 / 83			

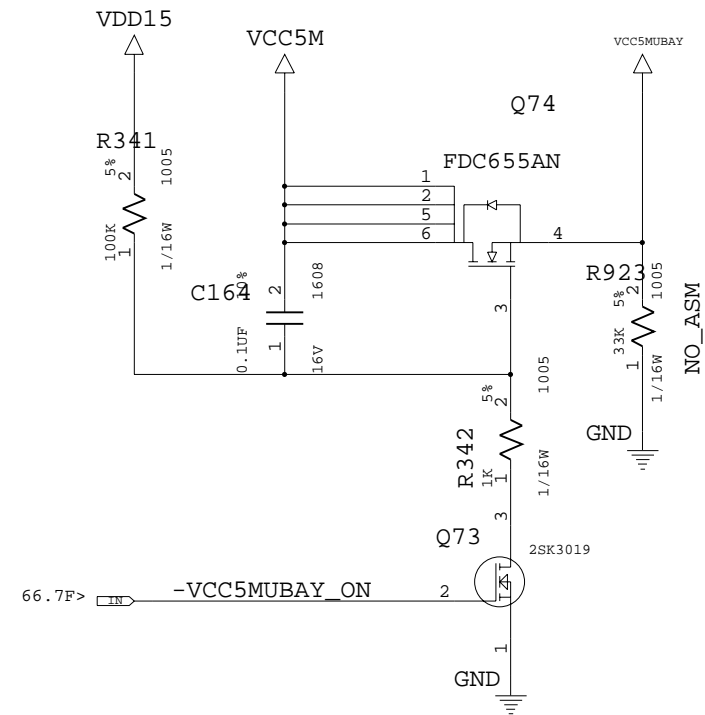
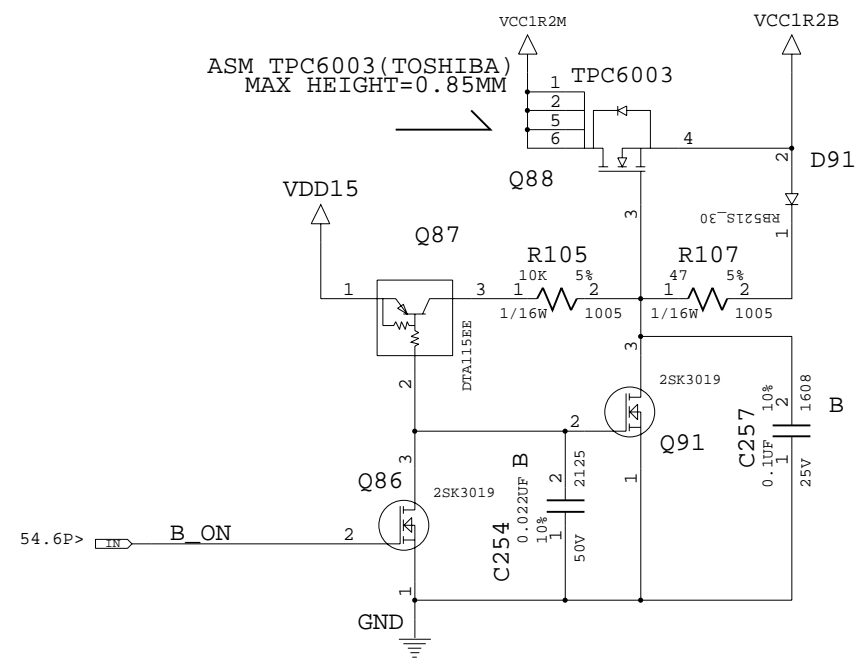

93P4047

DESIGNER	Y.Y	06/12/03	PART NO.	93P4047	IBM
CHECKED	Y.I	06/12/03	TITLE TOKYO-3 SVT(2.00)		
APPROVED	K.T	06/12/03	LOAD SW		THIS DOCUMENT IS THE PROPERTY OF IBM ITS USE IS AUTHORIZED ONLY FOR RESPONDING TO A REQUEST FOR QUOTATION OR FOR THE PERFORMANCE OF WORK FOR IBM. ALL QUESTIONS MUST BE REFERRED TO THE IBM PURCHASING DEPARTMENT.
CLASS			IBM CONFIDENTIAL		

DATE	06/12/03	EC NO.	J18444	PART NO.	93P4047
DEVELOPMENT NO.		Q/M	83 / 83		

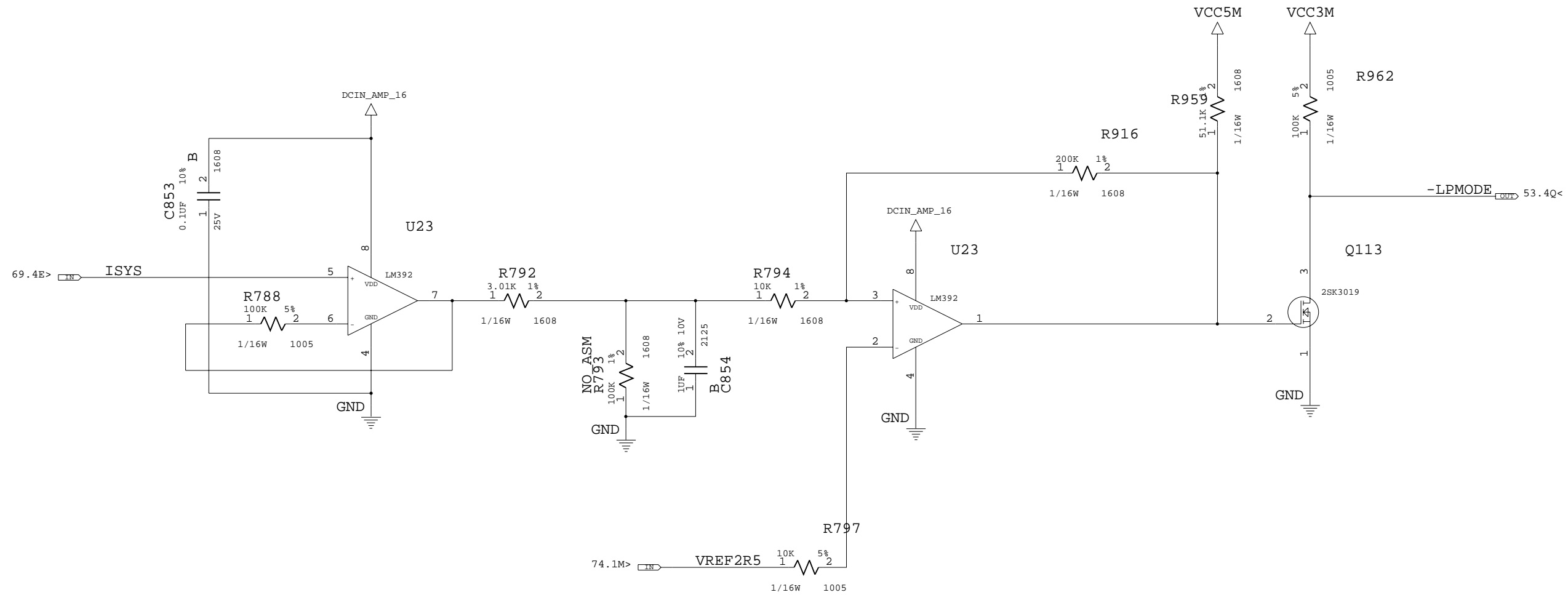

93P4047

DESIGNER	Y.Y	06/12/03	PART NO.	93P4047	IBM
CHECKED	Y.I	06/12/03	TITLE	TOKYO-3 SVT(2.00)	
APPROVED	K.T	06/12/03	CLASS	MAX POWER CONTROL	
THIS DOCUMENT IS THE PROPERTY OF IBM ITS USE IS AUTHORIZED ONLY FOR RESPONDING TO A REQUEST FOR QUOTATION OR FOR THE PERFORMANCE OF WORK FOR IBM. ALL QUESTIONS MUST BE REFERRED TO THE IBM PURCHASING DEPARTMENT.					IBM CONFIDENTIAL