

Diamond-3 Intel Calpella Platform with UMA GFX

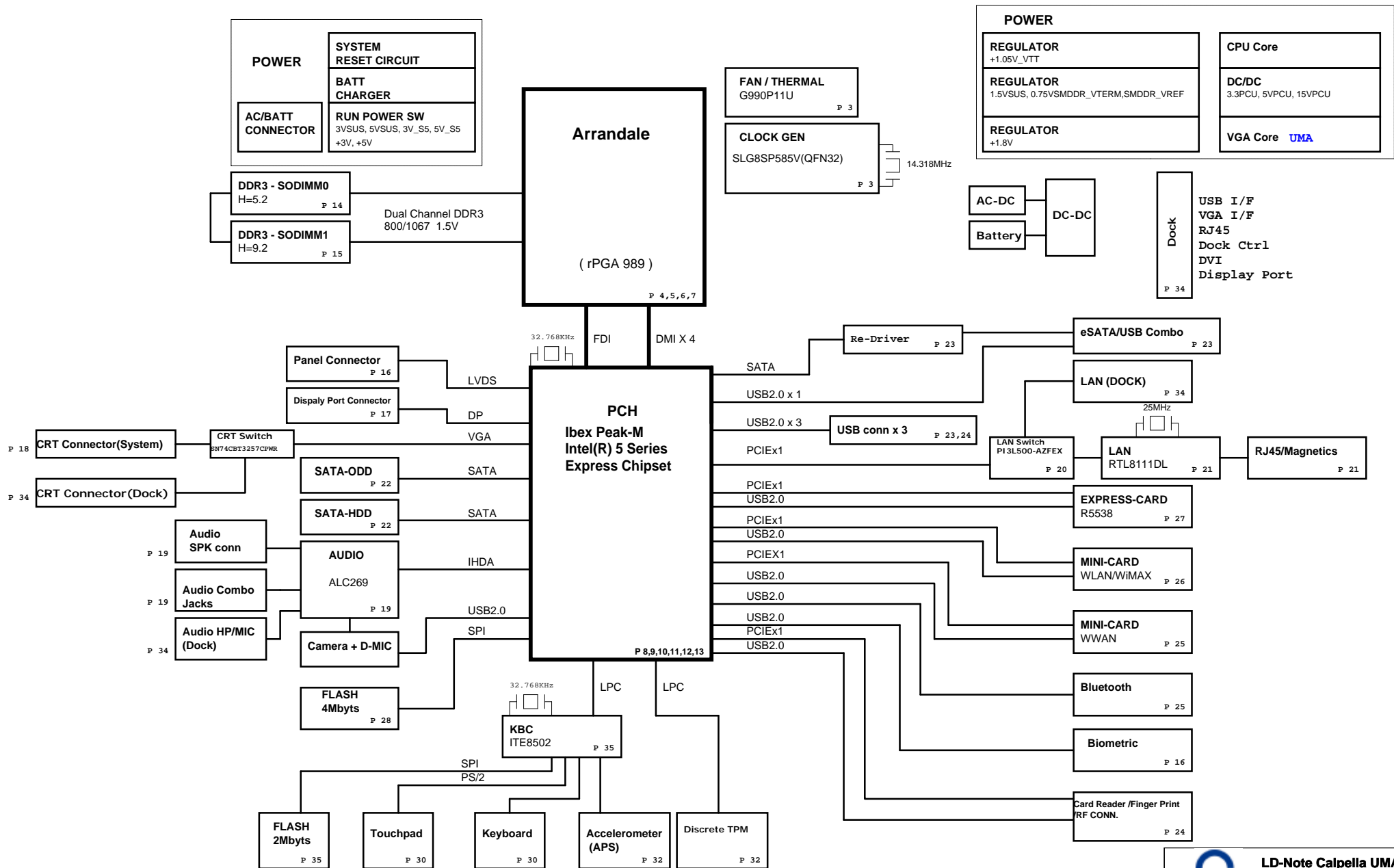
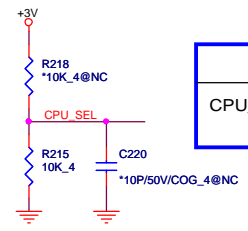
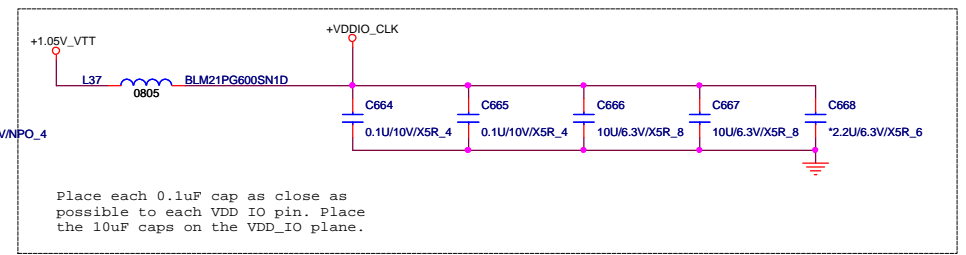
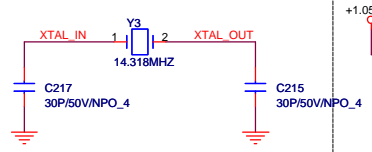
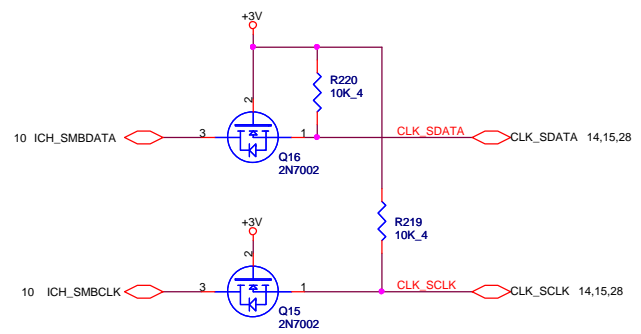
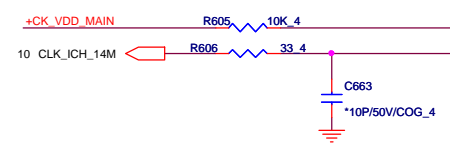
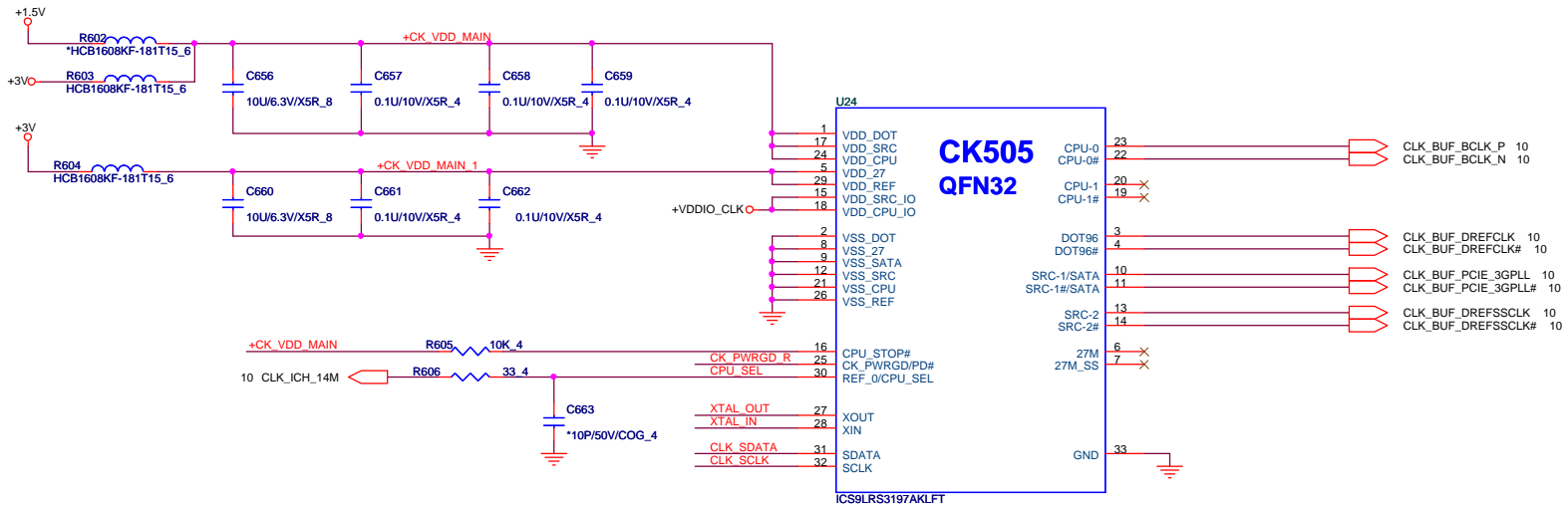

Table of Contents

PAGE	DESCRIPTION
01	BLOCK DIAGRAM
02	FRONT PAGE
03	CLOCK GENERATOR
04-07	Auburndale PROCESSER
08-13	Ibex Peak-M
14-15	DDRIII SO-DIMM
16	LCD & LID CON
17	HDMI PORT(PS8101)
18	CRT CONN
19	AUDIO CODEC(ALC269Q)
20	LAN(8111DL)
21	SATA HDD/CD-ROM
22	USB X2/SIM_CARD/LEDs/RF
23	CARD READER/USB/SIM CONN
24	MINI-Card (WWAN)
25	MINI-Card (WLAN)
26	ONFI
27	Express Card
28	K/B, T/P
29	BlueTooth
30	FAN /THERMAL
31	G-SENSOR
32	B TO B CON
33	TPM & RFID EEPROM
34	KBC IT8502E
35	HOLD & SKEW
36	Discharge
37	Charger (ISL88731)
38	DDR3/0.75V(TPS51116REGR)
39	1.05V_VTT (RT8204)
40	3V/5V (ISL6237IRZ-T)
41	CPU (ISL62882)
42	GFX_VCC (MAX17028)
43	XDP & JTAG
44	Power Block Dianram
45	Schematic Value Descript
46	BOM Matrix Table

Power States

POWER PLANE	VOLTAGE	PAGE	DESCRIPTION	CONTROL SIGNAL	ACTIVE IN
VIN	10V~+20V	16,36,37,38,39,40,41,42	MAIN POWER		S0~S5
+3VRTC	+3.0V~+3.3V	9,12,34	RTC		S0~S5
3VPCU	+3.3V	9,16,20,23,28,32,34,36,37,40,42	ITE8502 POWER	3V5V_EN	S0~S5
5VPCU	+5V	36,37,38,39,40,42	DC/DC POWER IC SOURCE	3V5V_EN	S0~S5
+15V	+15V	16,31,36,38,39,40	LARGE POWER	3V5V_EN	S0~S5
LANVCC	+3.3V	20,36	LAN POWER	LAN_ON	
5V_S5	+5V	12,22,23,36	PCH SUS POWER	S5_ON	S0~S3
3V_S5	+3.3V	8,9,10,11,12,36	Sys Management,PCH Resume Well, Intel HD Audio,USB,WLAN,WiMAX POWER	S5_ON	S0~S3
5VSUS	+5V	16,32,36,41,42	SLP_S4# CTRLD POWER	SUSON	S0~S3
3VSUS	+3.3V	8,23,27,34,36,42	SLP_S4# CTRLD POWER	SUSON	S0~S3
1.5VSUS	+1.5V	4,6,12,14,15,36,38,39	DDR3 SODIMM POWER	SUSON	S0~S3
0.75VSMDDR_VTERM	+0.75V	14,15,36,38	DDR3 SODIMM REFERENCE POWER	MAINON	S0
+5V	+5V	8,12,16,17,18,19,21,28,30,34,36,37	SLP_S3# CTRLD POWER	MAINON	S0
+3V	+3.3V	3,4,8,9,10,11,12,14,15,16,17,18,19,20,21,22,23,24,25,26,27,29,30,31,32,33,34,36,37,38,39,40,41,42,43	SLP_S3# CTRLD POWER	MAINON	S0
+1.8V	+1.8V	6,12,26,36,42	LVDS,NVM POWER	MAINON	S0
+1.5V	+1.5V	12,24,25,27,38,39	Mini PCIe,Express Card POWER	MAIND	S0
+1.05V_VTT	+1.05V	3,4,6,8,10,11,12,36,39,41,43	Auburndale VTT POWER/PCH CORE POWER	MAINON	S0
+VCC_GFX_CORE		6,36,42	VGA CORE POWER	GFXVR_EN	S0
VCC_CORE		6,36,41	CPU CORE POWER	VRON	S0
LCDVCC	+3.3V	16	LCD Power	ENVDD	S0
+5V_ODD	+5V	21	ODD Power	MAINON#	S0
+5V_HDD	+5V	21	HDD Power	MAINON#	S0
BAT-V	+10V~+17V	37	MAIN BATTERY	CHG_PBATT	S0~S5



	0	1
CPU_SEL	CPU0/1=133MHz (default)	CPU0/1=100MHz

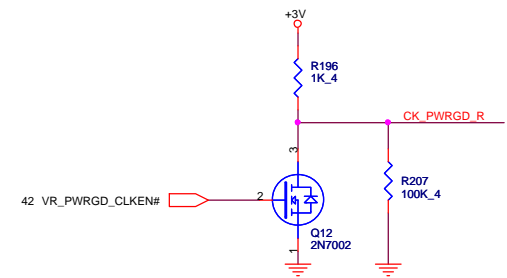

ARRANDALE PROCESSOR (CLK, MISC, JTAG)

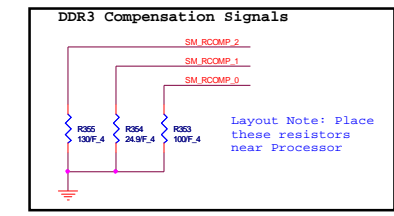
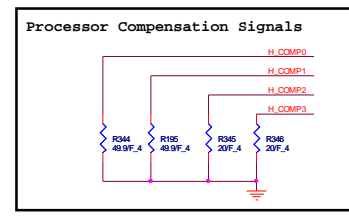
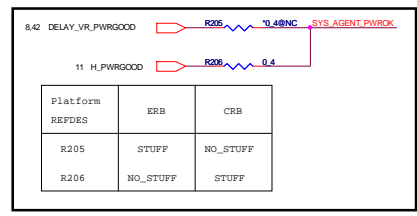
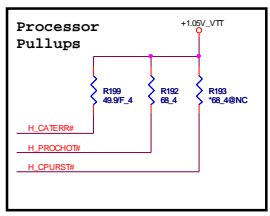
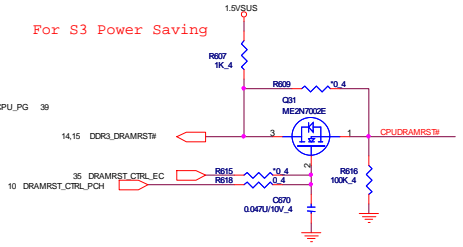
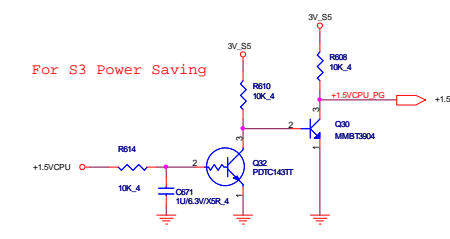
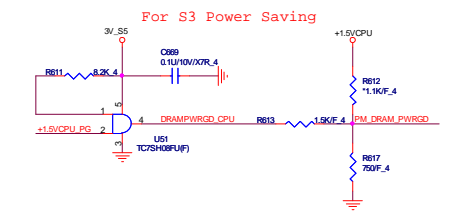
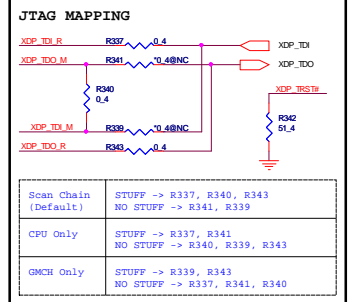
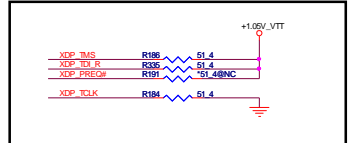
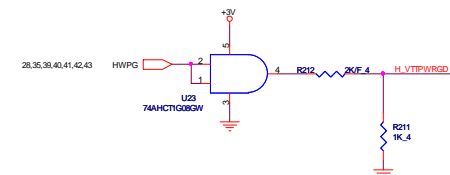
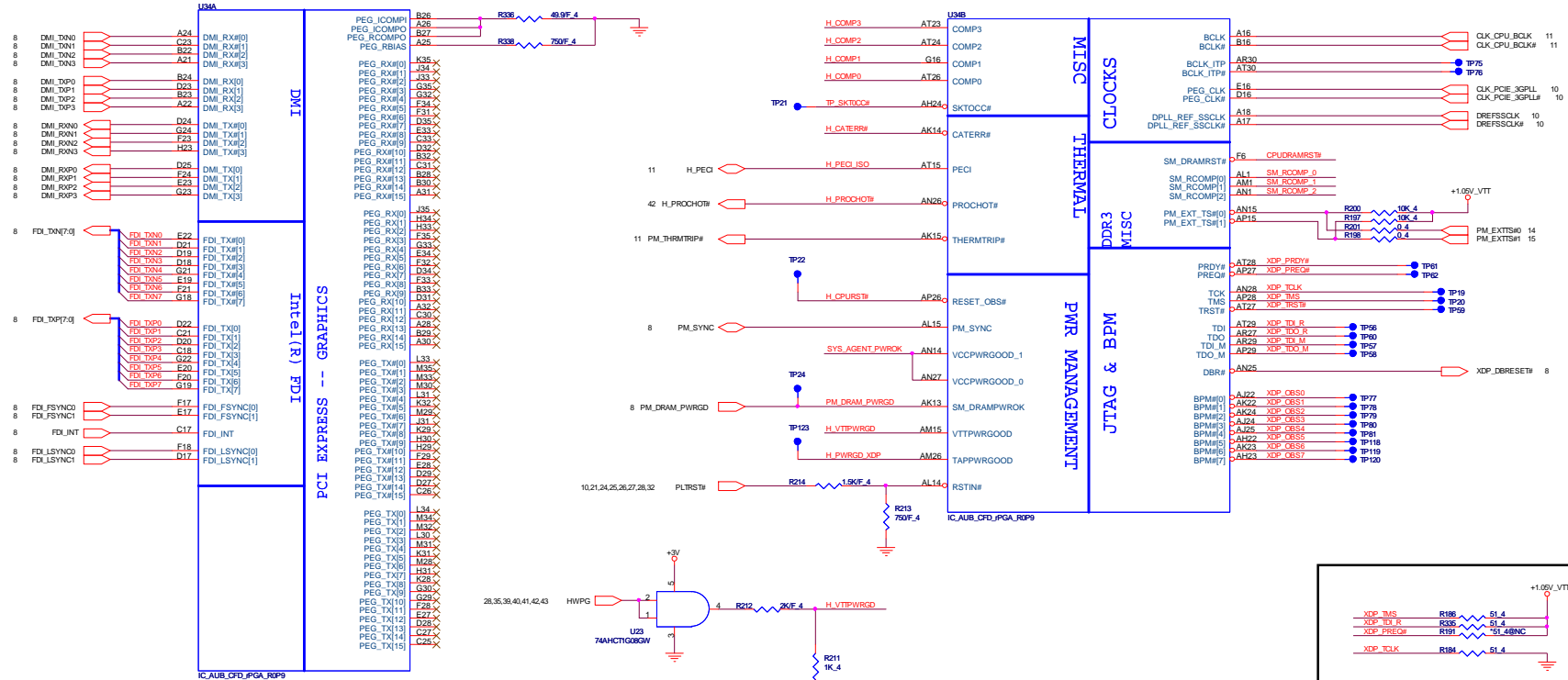

ARRANDALE PROCESSOR (DDR3)

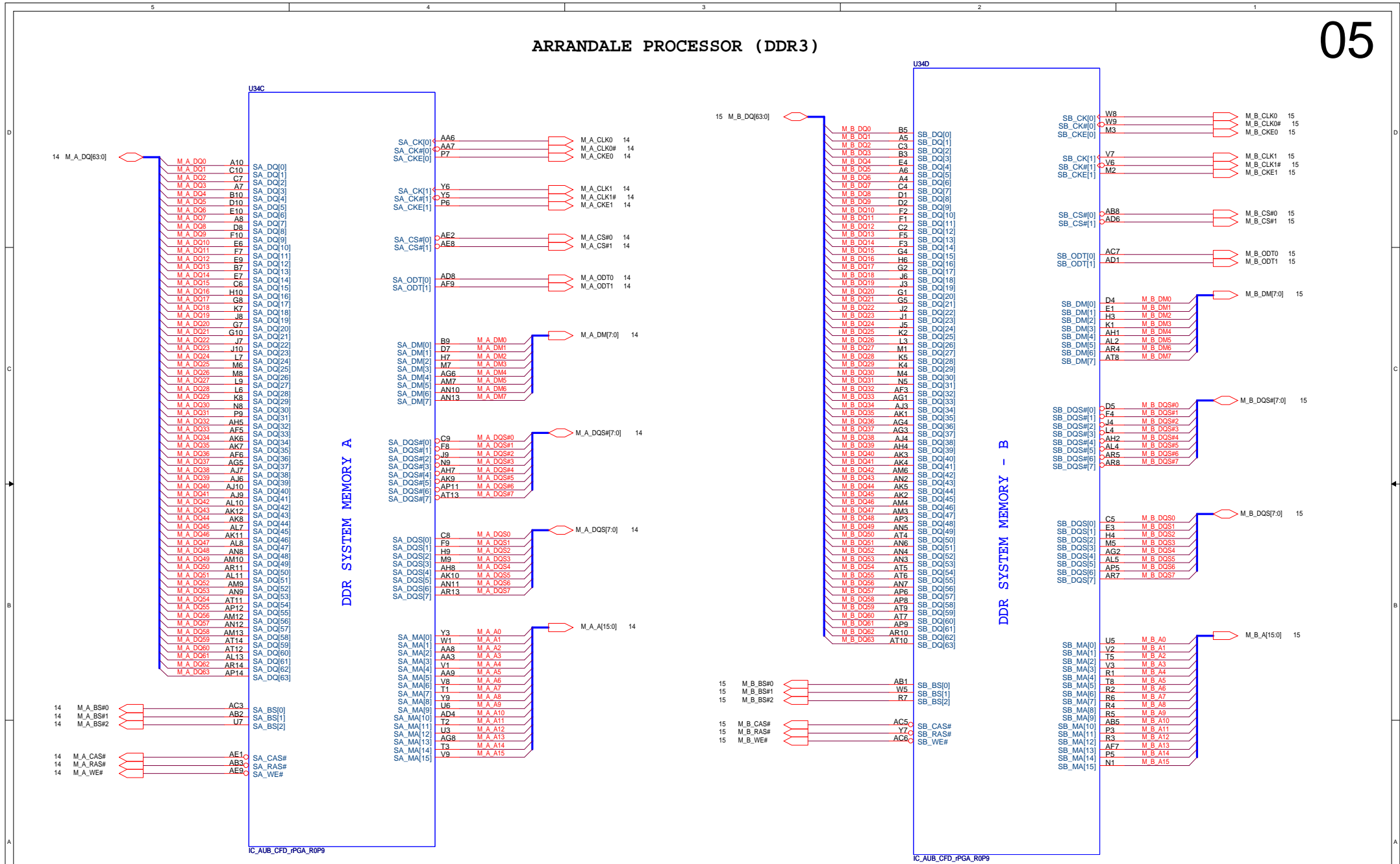

IC_AUB_CFD_rPGA_R0P9

IC_AUB_CFD_rPGA_R0P9

LD-Note Calpella UMA
Quanta Computer Inc.

Size	Document Number	Rev
Custom	AUBURND2 2/4	
Date:	Tuesday, November 17, 2009	Sheet 5 of 46

ARRANDALE PROCESSOR (GND)

ARRANDALE PROCESSOR(RESERVED, CFG)

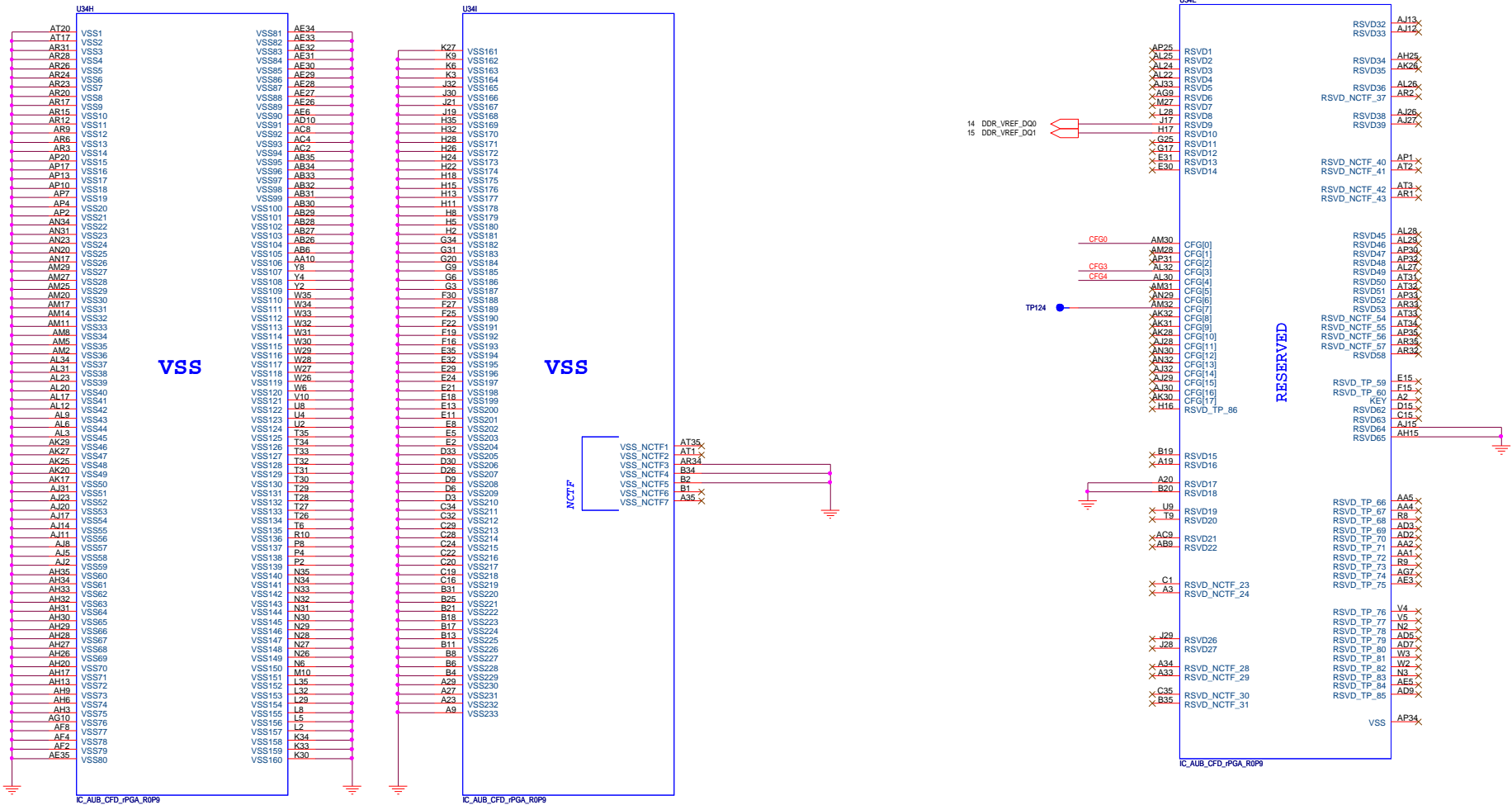

	1	0
CFG4 (Display Port Presence)	Disabled; No Physical Display Port attached to Embedded Display Port	Enabled; An external Display port device is connected to the Embedded Display port
CFG0 (PCI-Epress Configuration Select)	Single PEG	Bifurcation enabled
CFG3 (PCI-Epress Static Lane Reversal)	Normal Operation	Lane Numbers Reversed

LD-Note Calpella UMA
Quanta Computer Inc.

Size: Custom Document Number: **AUBURND4 4/4 (GND)** Rev:

Date: Tuesday, November 17, 2009 Sheet: 7 of 46

12,35 +3VRTC
 16,21,24,33,34,35,37,38,41,43 3VPCU
 3,4,8,10,11,12,14,15,16,17,18,19,21,22,23,24,25,26,27,28,29,31,32,33,34,35,37,39,40,41,42 +3V
 4,8,10,11,12,23,26,28,37 3V_S5
 3,4,6,8,10,11,12,37,40,42,43 +1.05V_VTT

RTC Circuitry

CMOS Settings		J2
Clear CMOS		1-2
Save CMOS		1-X (Default)

TPM Settings		J3
Clear ME RTC registers		1-2
Save ME RTC registers		1-X (Default)

IBEX PEAK-M (HDA, JTAG, SATA)

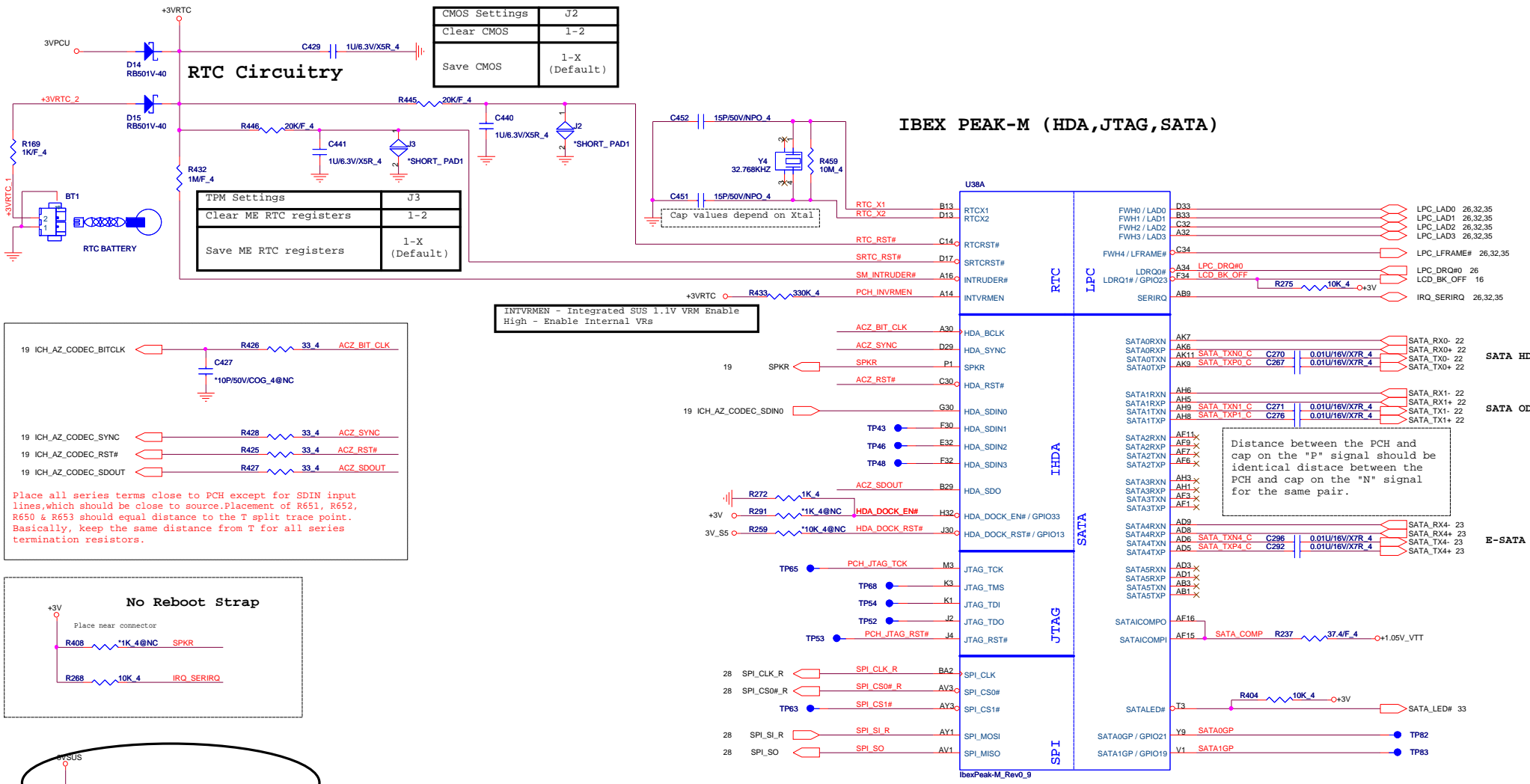

INTVRMEN - Integrated SUS 1.1V VRM Enable
 High - Enable Internal VRs

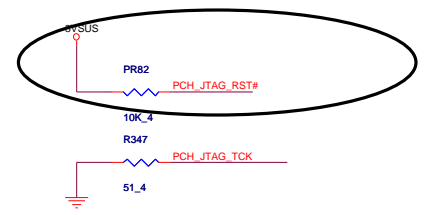
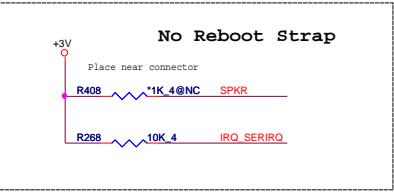
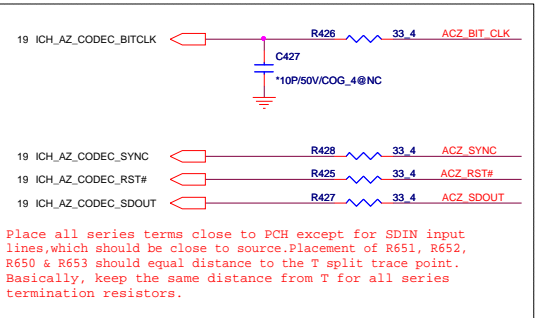

Distance between the PCH and cap on the "P" signal should be identical distance between the PCH and cap on the "N" signal for the same pair.

IBEX PEAK-M (GPIO, VSS_NCTF, RSVD)

3,4,8,9,10,12,14,15,16,17,18,19,21,22,23,24,25,26,27,28,29,31,32,33,34,35,37,39,40,41,42
4,8,9,10,12,23,26,28,37
3,4,6,8,9,10,12,37,40,42,43

+3V
3V_S5
+1.05V_VTT

11

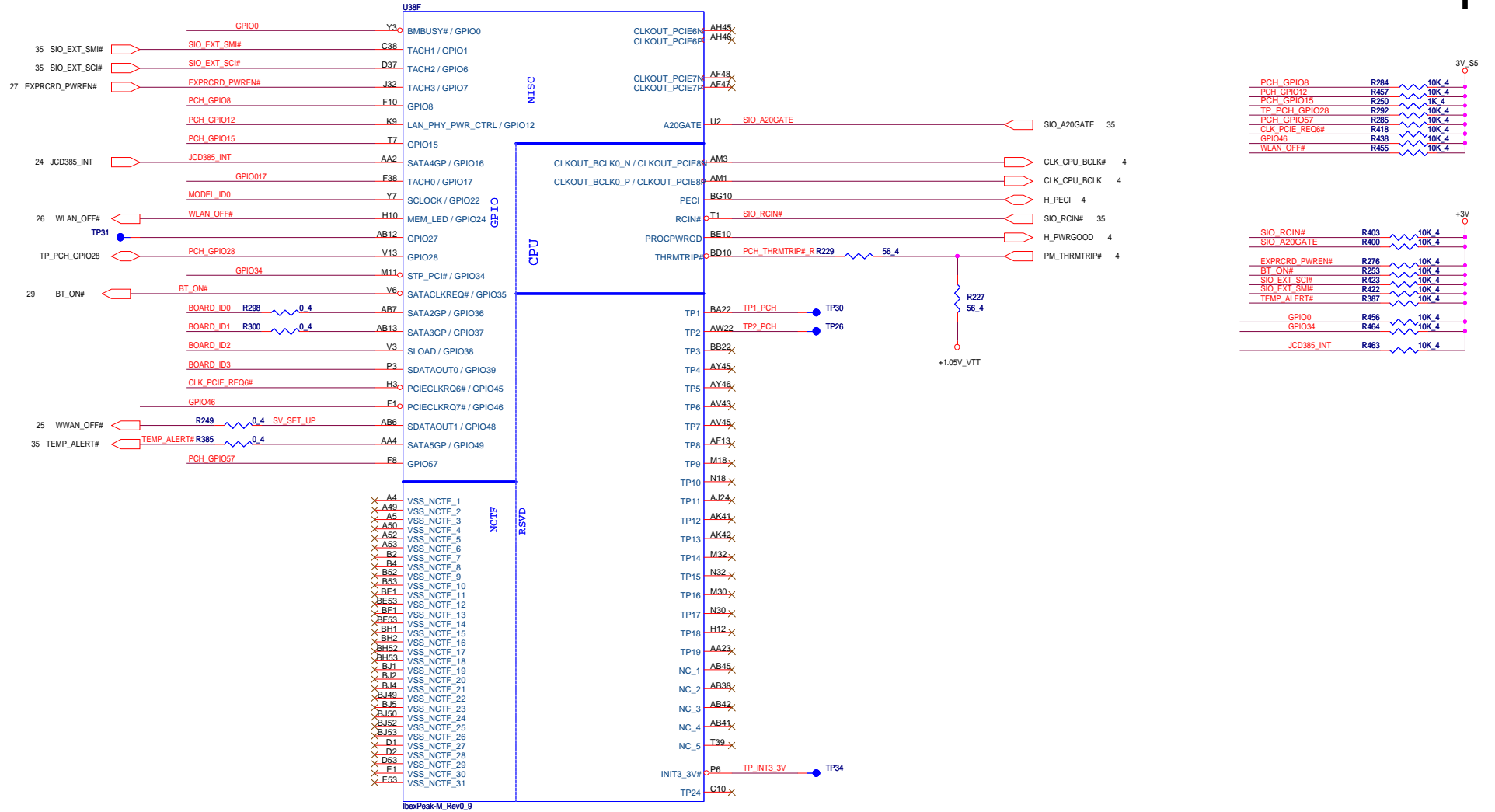

Board ID For Function	ID3 GPIO39	ID2 GPIO38	ID1 GPIO37	ID0 GPIO36
SDV	0	0	0	0
SIV	0	0	0	1
SIT	0	0	1	0
SVT	0	0	1	1
SOVP	0	1	0	0

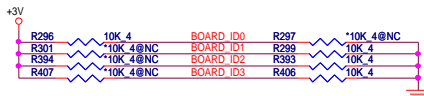

Model ID	MODEL_ID0
14"	0
15"	1

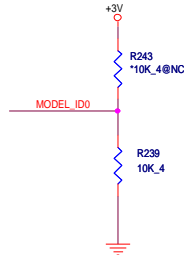

TPM physical presence	
PCH_GPIO57	Low: Default

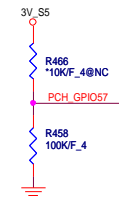

SV_SET_UP	1-X High = Strong (Default)
-----------	-----------------------------

LD-Note Calpella UMA
Quanta Computer Inc.

Size: Custom | Document Number: **IBEX PEAK-M 4/6** | Rev: | Date: Tuesday, November 17, 2009 | Sheet: 11 of 46

IBEX PEAK-M (GND)

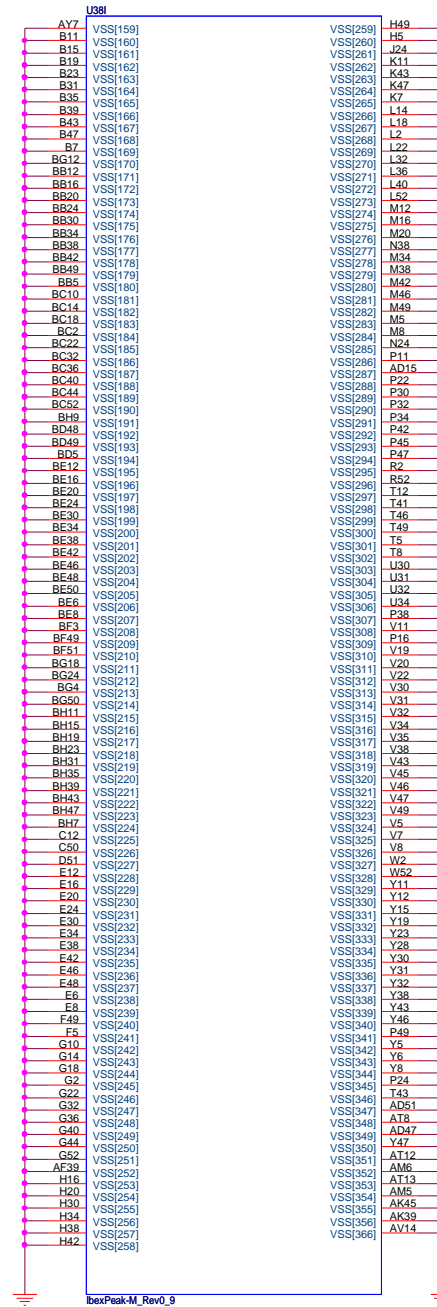
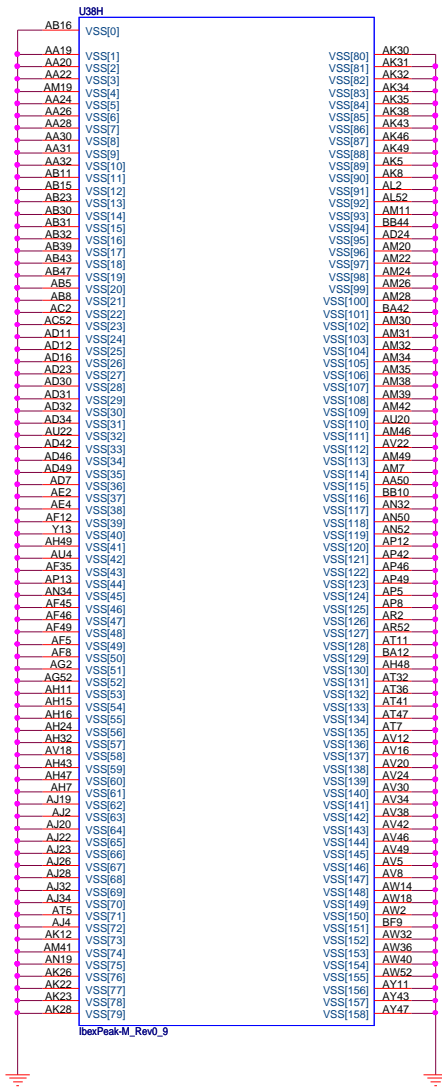

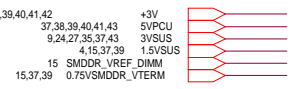
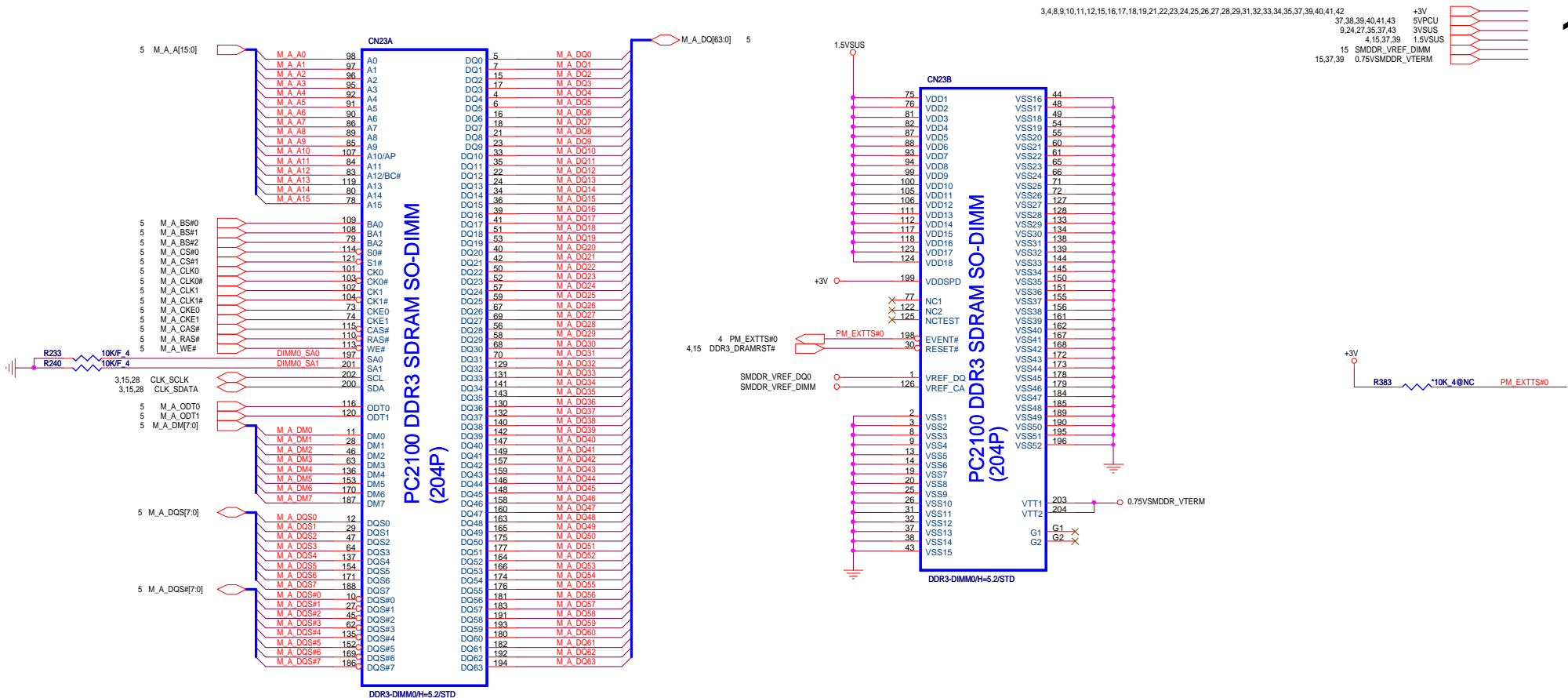

LD-Note Calpella UMA
Quanta Computer Inc.

Size	Document Number	Rev
Custom	IBEX PEAK-M 6/6	
Date:	Tuesday, November 17, 2009	Sheet 13 of 46

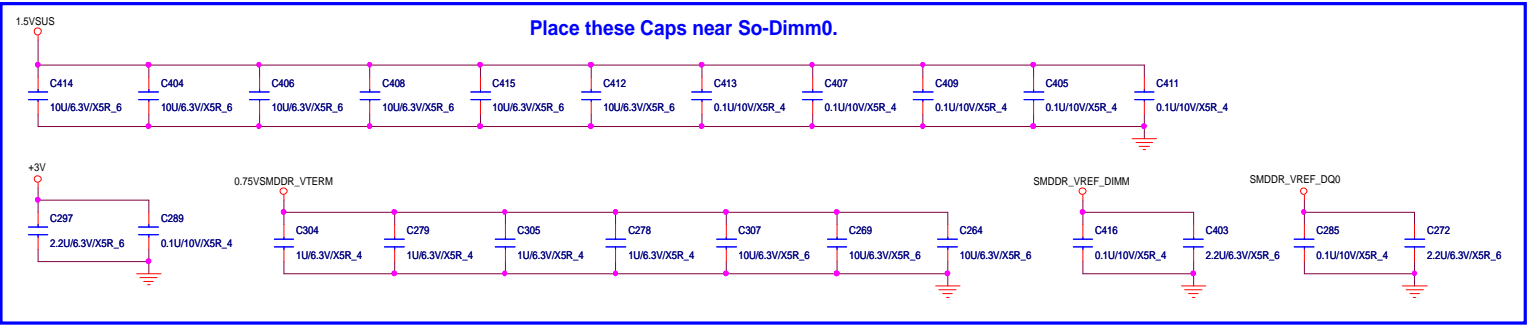

Place these Caps near So-Dimm0.





LD-Note Calpella UMA
Quanta Computer Inc.

Size	Document Number		Rev
Custom	DDR3 DIMM-1(H=5.2)		
Date:	Tuesday, November 17, 2009	Sheet	14 of 46

LCDVCC

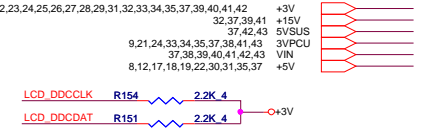
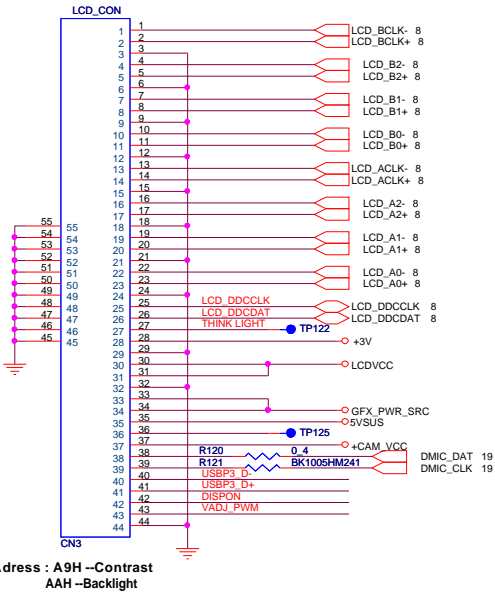
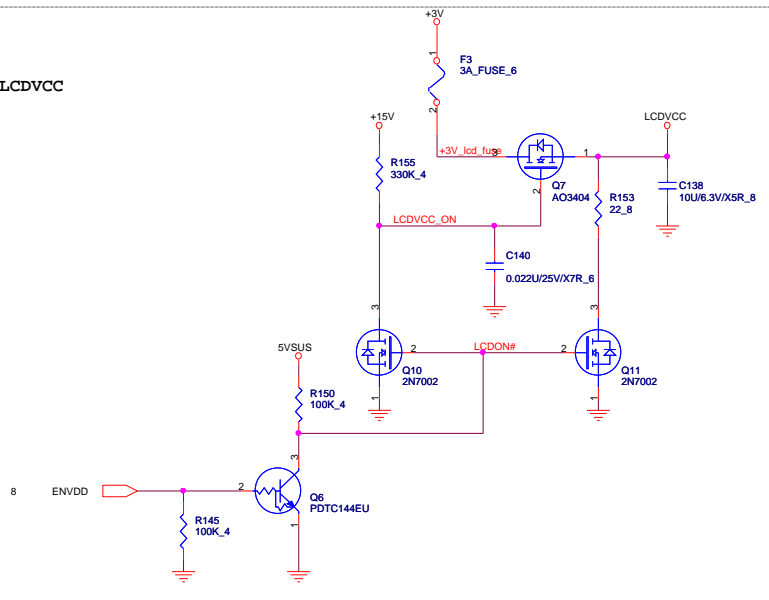

Adress : A9H --Contrast
AAH --Backlight

back light

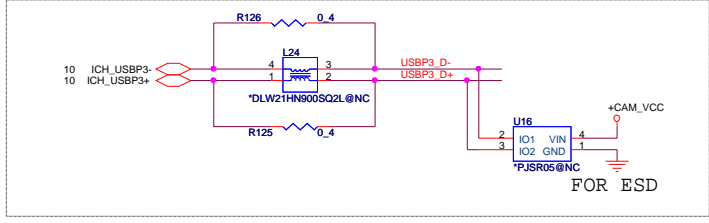
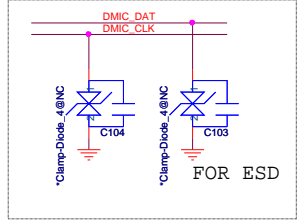
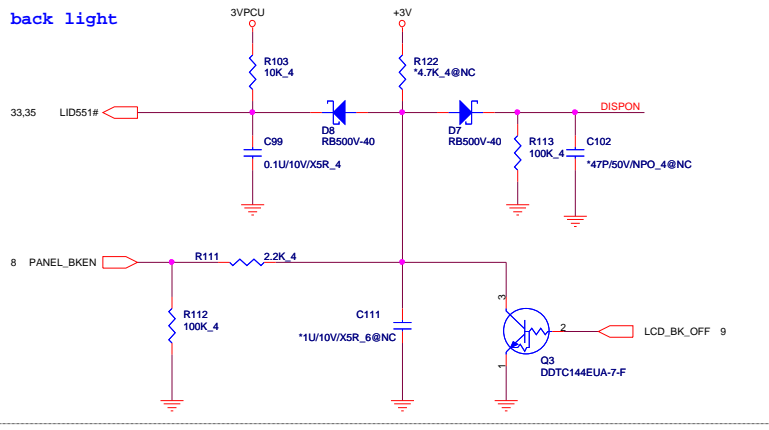

CAMERA VCC Control

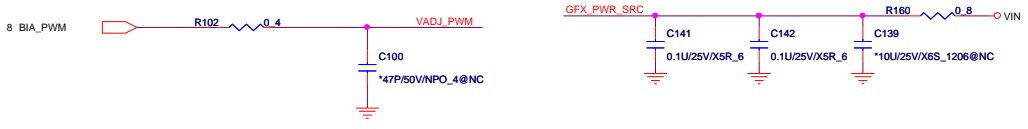
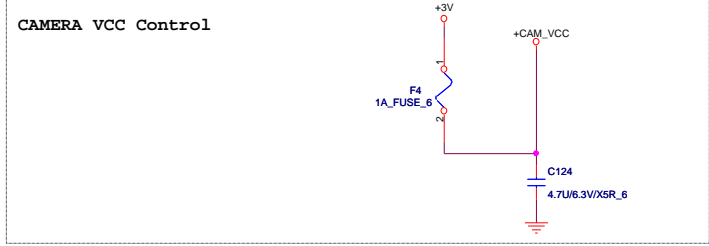

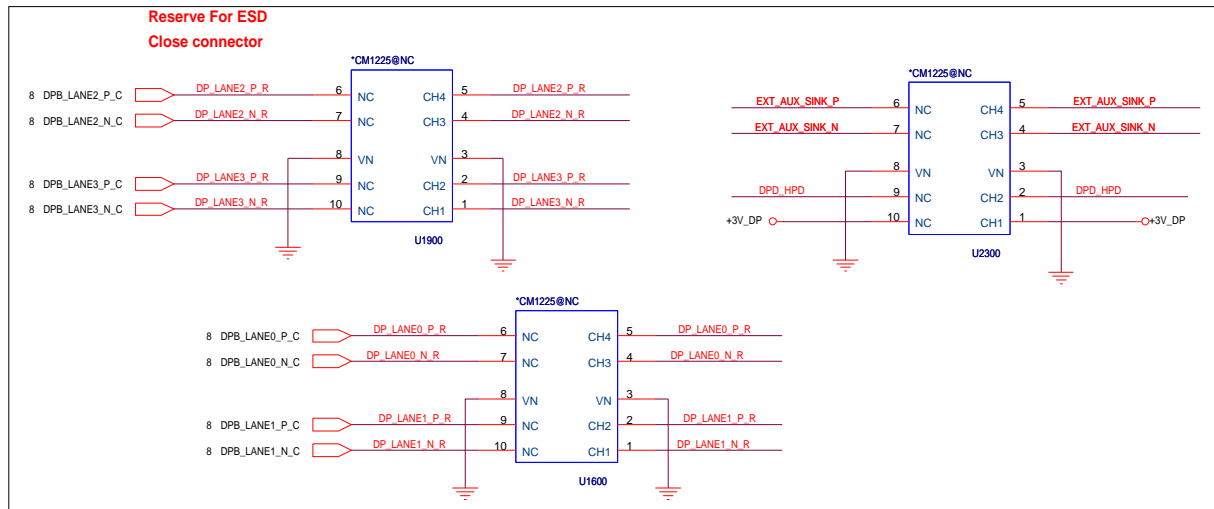
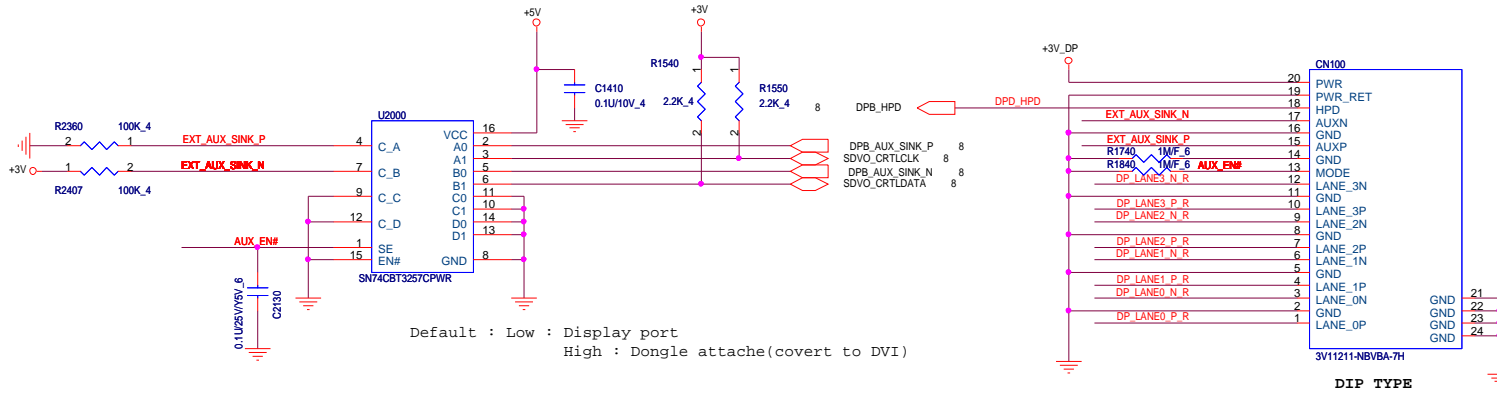

Layout Topology

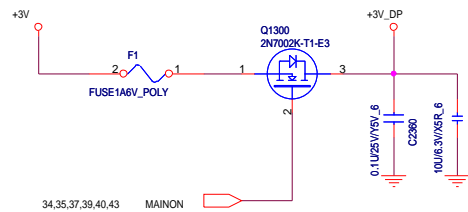
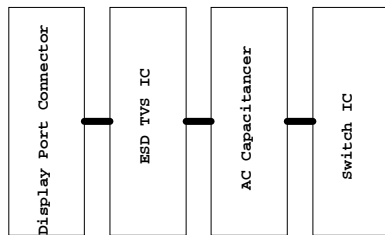

Layout Note:
Setting R,G,B trace
impedance to 50 ohm.

Layout Note:
40mil

Place near
U5001,U5002 < 200 mil

Place near CRT connector
< 200 mil

ESD PROTECTION

SEL	FUNCTION(COM)
LOW	IN_x0
HIGH	IN_x1



LD-Note Calpella UMA
Quanta Computer Inc.

Size	Document Number	Rev
Custom		
CRT CONN		
Date:	Tuesday, November 17, 2009	Sheet 18 of 46

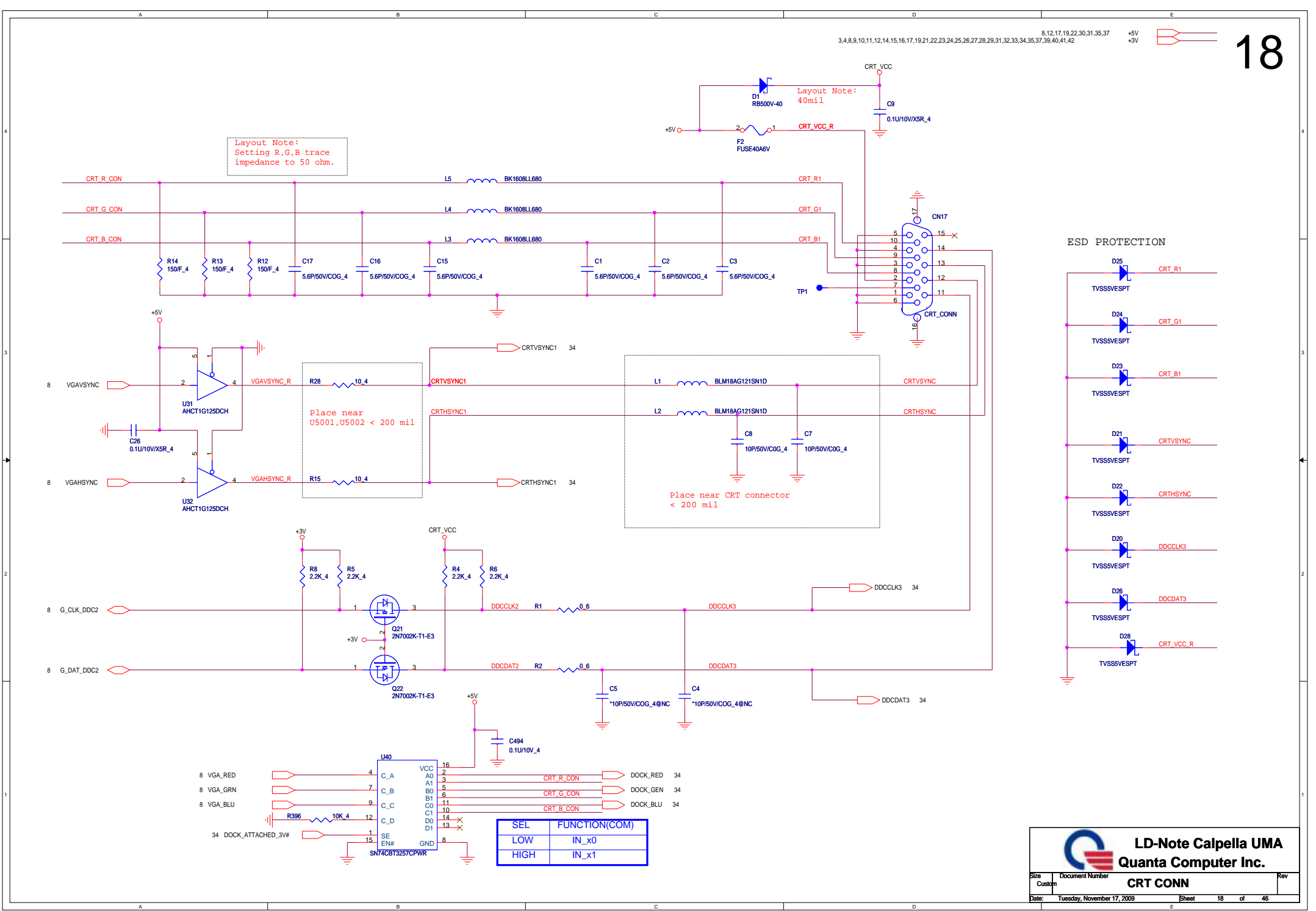

HDAudio Codec

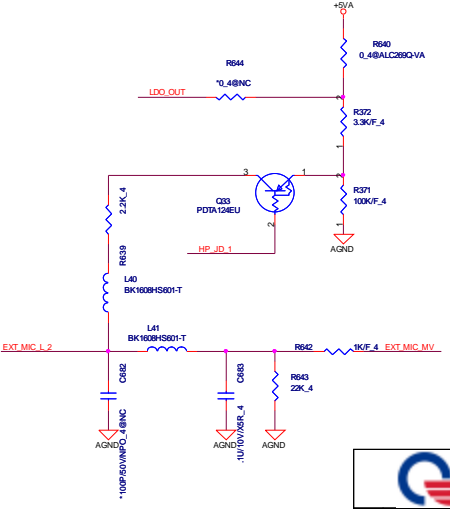
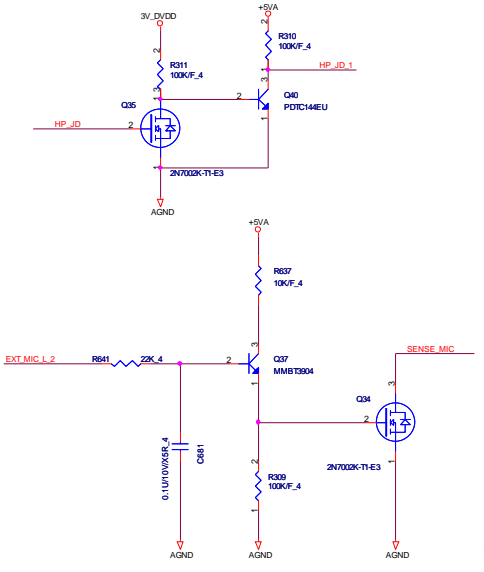
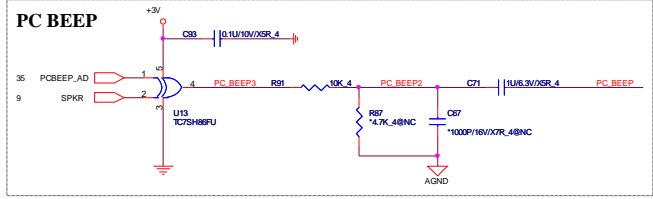
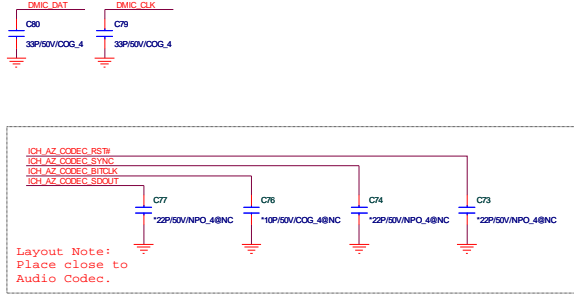
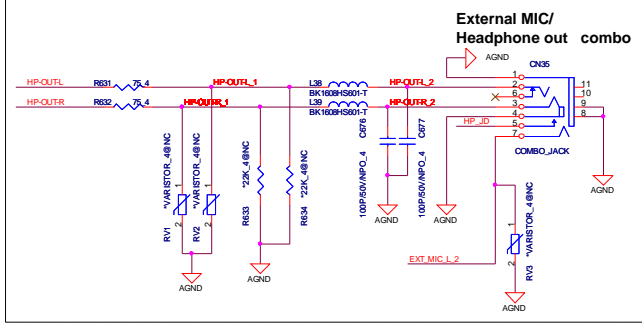
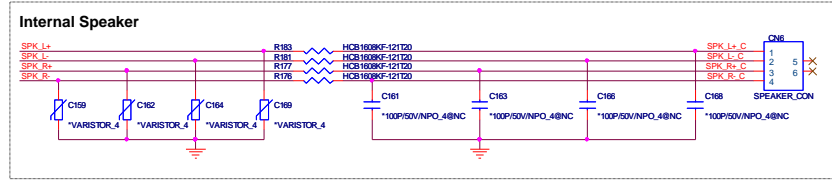
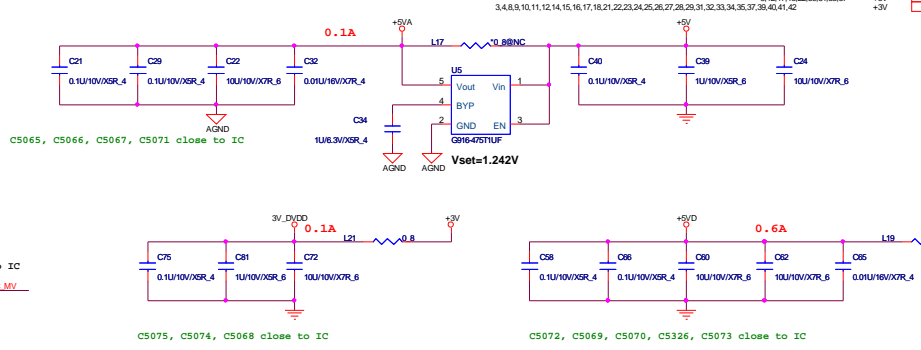
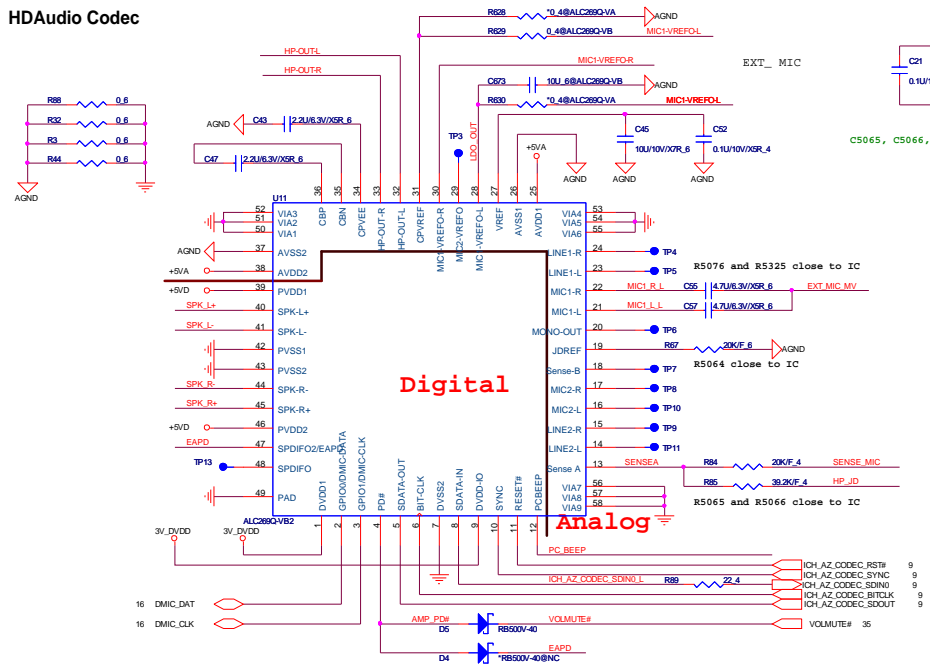

	VA	VB
R310	3.3K	2K
R640	ASM	
R644		ASM

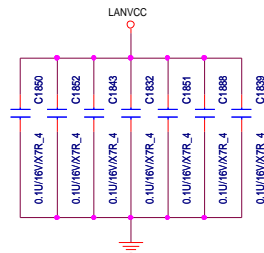
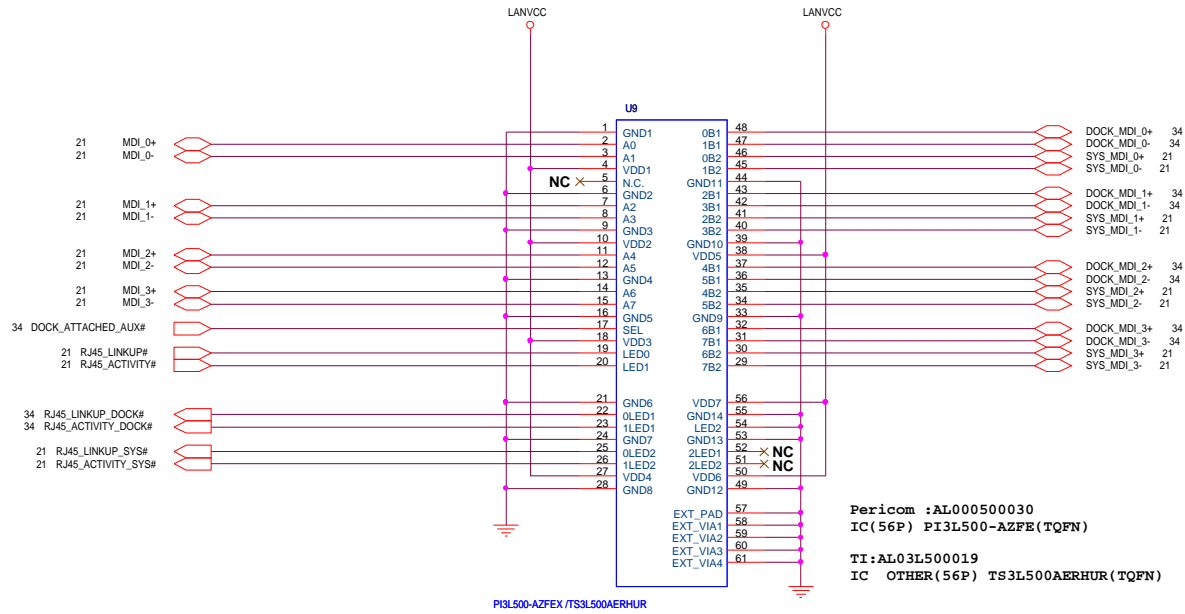

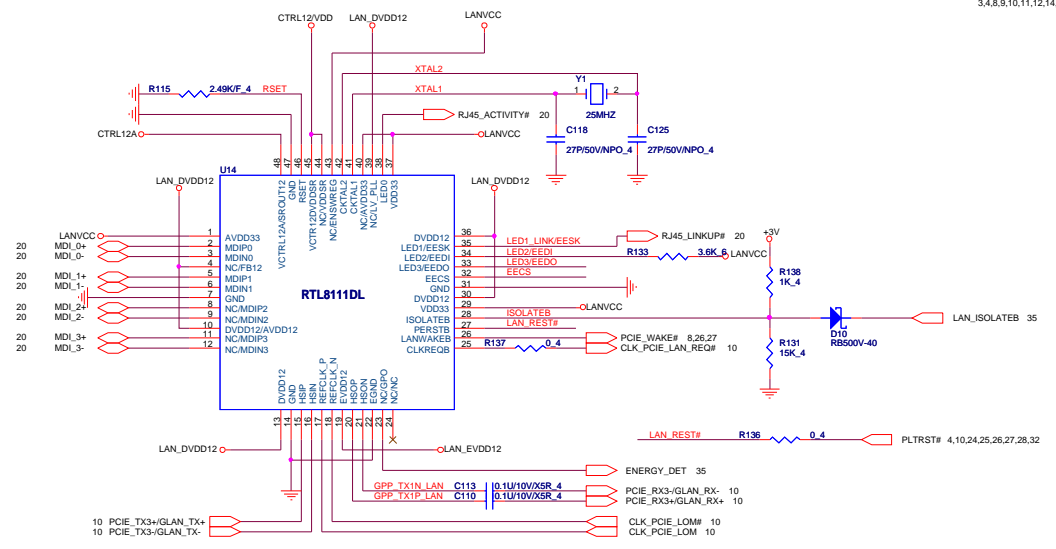
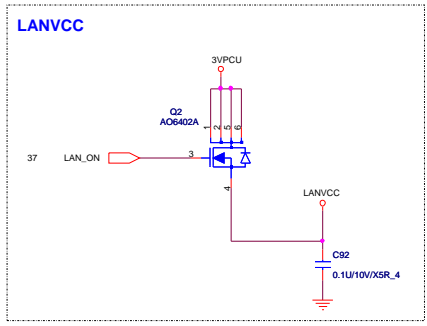

* C5116 and C5273 are for U5006 EVDD12 pin 19.

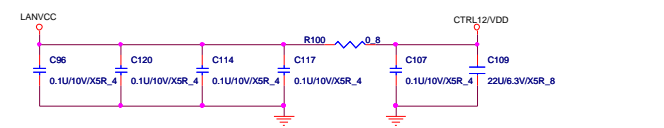

* C5110 to C5113 are for U5006 VDD33 pins-- 1, 29, 37 and 40.
Place C5113, C5094 closed to U5006 pins 44,45.

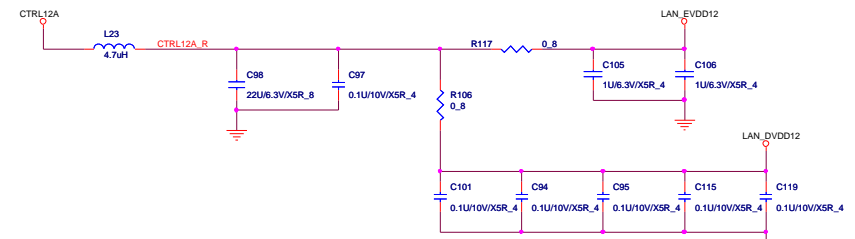

* C5119 to C5123 are for U5006 VDD12 pins-- 10, 13, 30, 36, 39.

Note 1: The Trace length between L1 and 8111DL's Pin 1 must be within 0.5 cm. C5 and C8 to L1 must be within 0.5cm. Refer to Layout guide for more detail.

Layout: All termination signal should have 20 mil trace

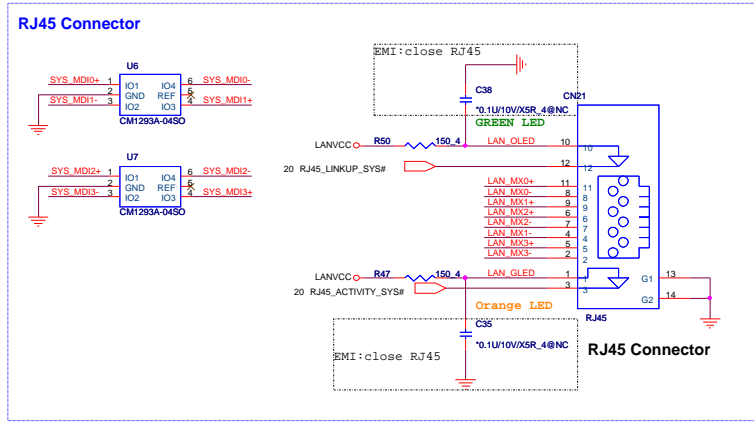
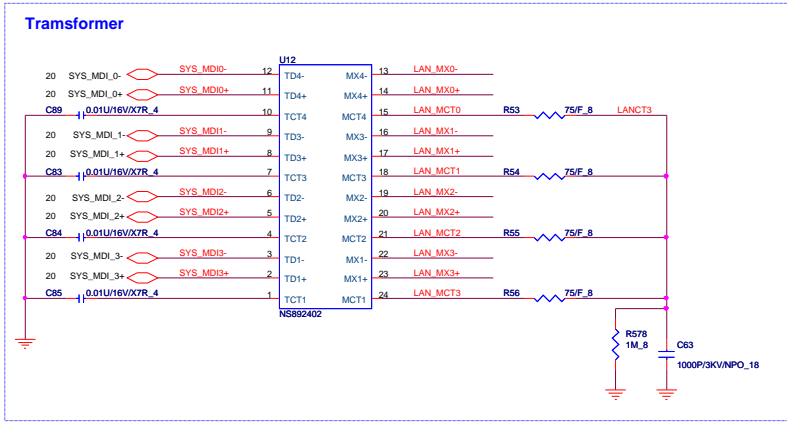

SATA Connector.

3,4,8,9,10,11,12,14,15,16,17,18,19,21,23,24,25,26,27,28,29,31,32,33,34,35,37,39,40,41,42 +5V +3V

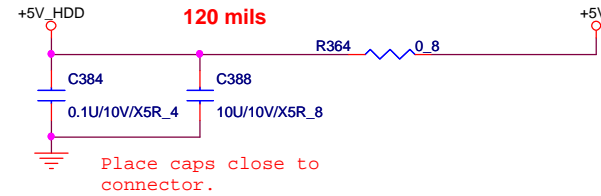
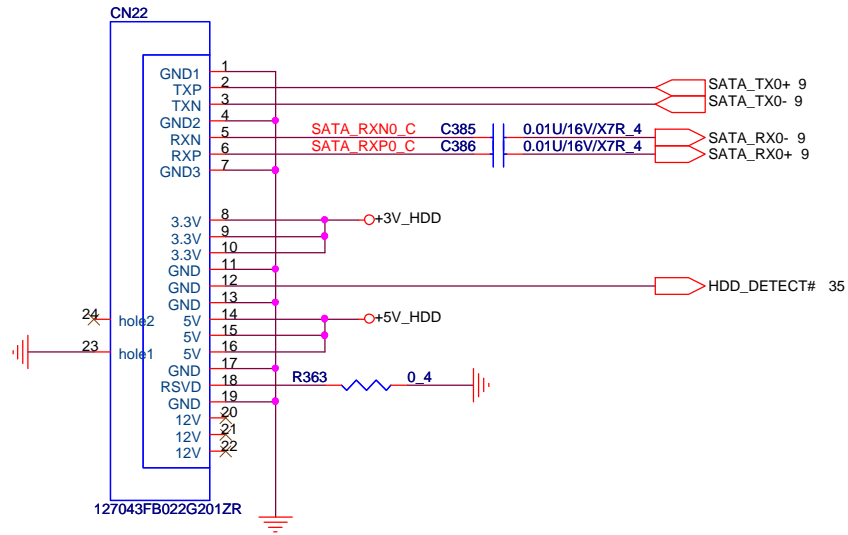

Place caps close to connector.

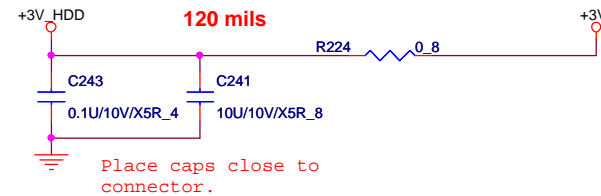

Place caps close to connector.

ODD Connector

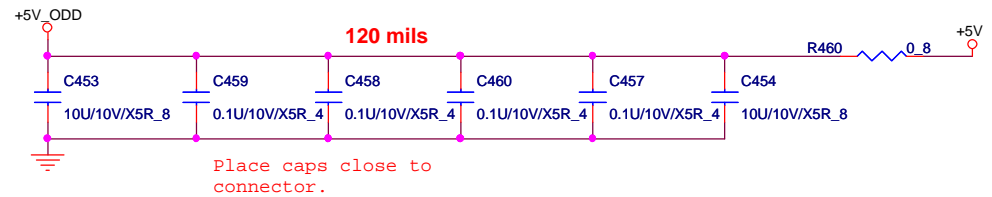
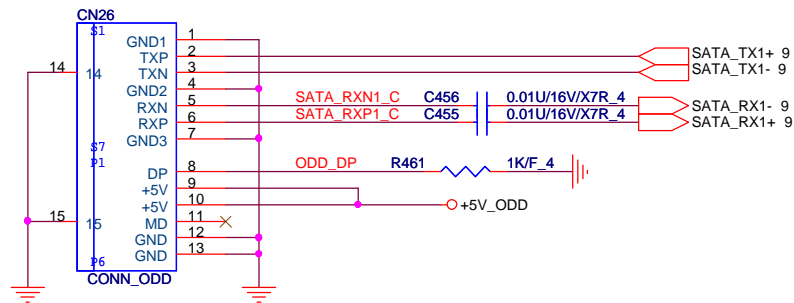

Place caps close to connector.

USBX1

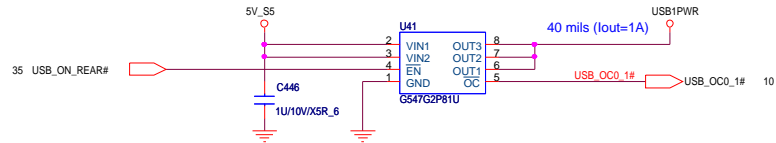

3.4, 8.8, 10.11, 12.14, 15, 16, 17, 18, 19, 21, 22, 24, 25, 26, 27, 28, 29, 31, 32, 33, 34, 35, 37, 39, 40, 41, 42

12.24, 37 5V_S5 +3V



23

Support Black-berry function

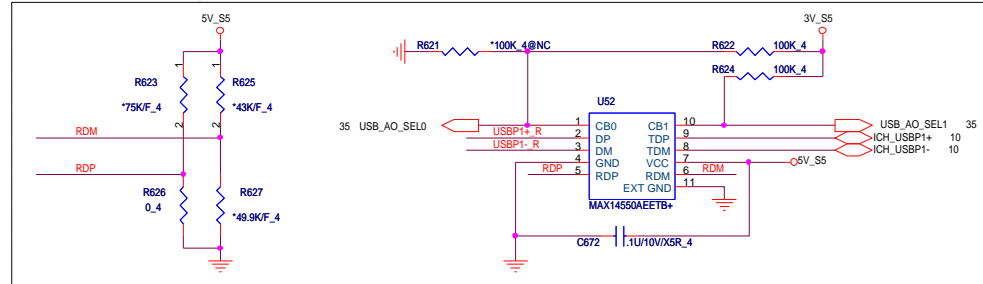

USB X1----> Wire to board conn

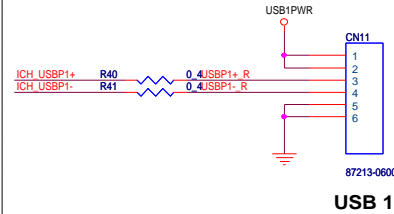

	w/ AOU3	w/o AOU3
R40	NO ASM	ASM
R41	NO ASM	ASM
U52	ASM	NO ASM
R622	ASM	NO ASM
R624	ASM	NO ASM
R626	ASM	NO ASM
C676	ASM	NO ASM

USB + E-SATA

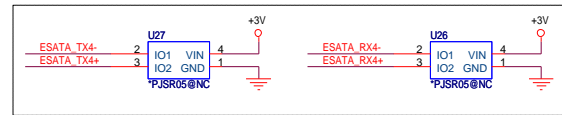
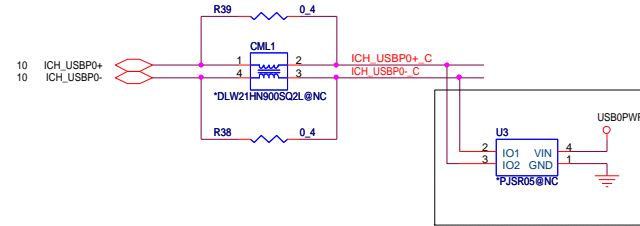
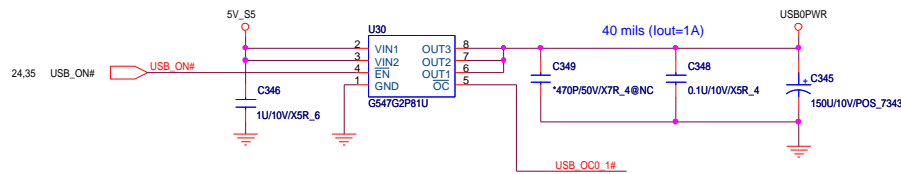

E-SATA RE-DRIVER

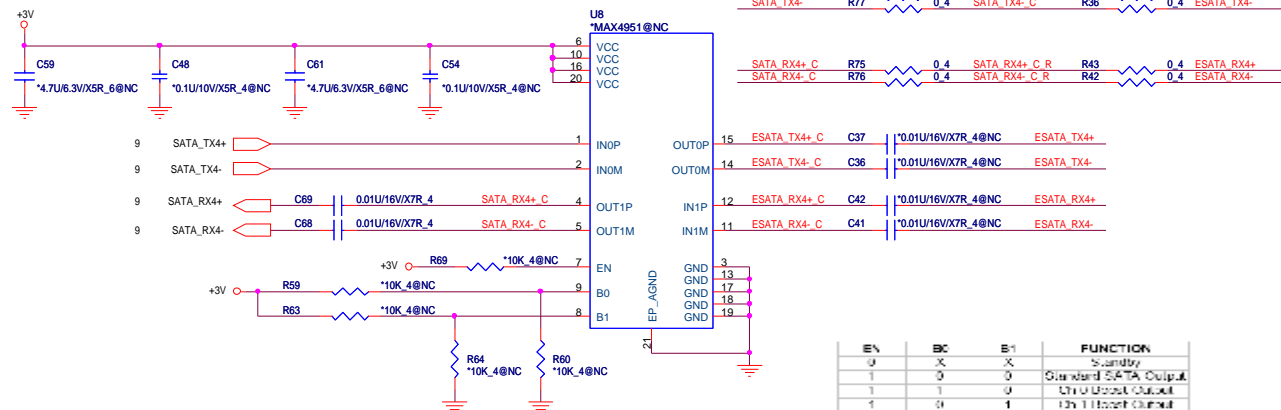

EN	BC	B1	FUNCTION
0	X	X	Standby
1	0	0	Standard SATA Output
1	1	0	Ch 0 Boost Output
1	0	1	Ch 1 Boost Output
1	1	1	Ch 0,1 Boost Output

LD-Note Calpella UMA
Quanta Computer Inc.
USB X1/USB+ESATA

Size: Custom Document Number: Rev:
 Date: Tuesday, November 17, 2009 Sheet: 23 of 46

3,4,8,9,10,11,12,14,15,16,17,18,19,21,22,23,25,26,27,28,29,31,32,33,34,35,37,39,40,41,42
 12,23,37 5V_S5
 +3V
 9,16,21,33,34,35,37,38,41,43 3VPCU
 9,27,35,37,43 3VSUS

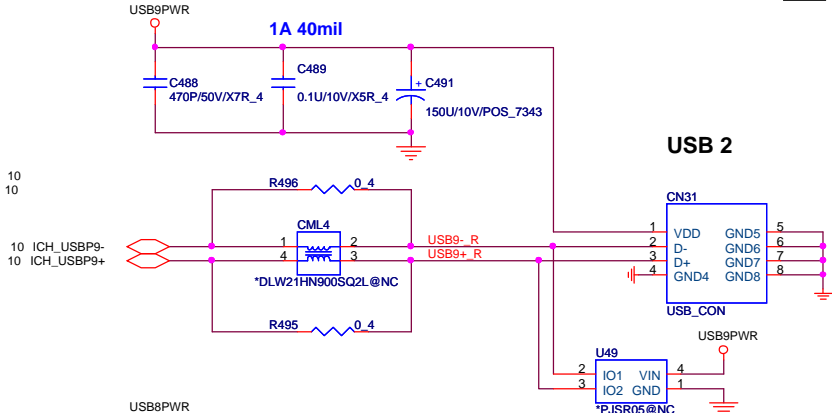
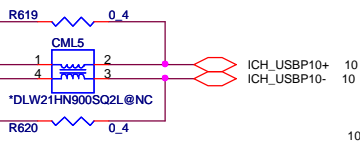
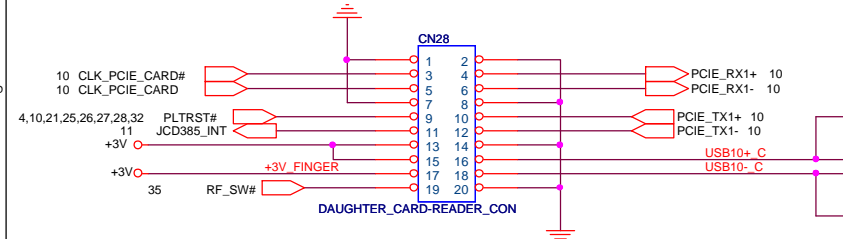

SIM Card CONN

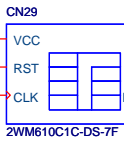
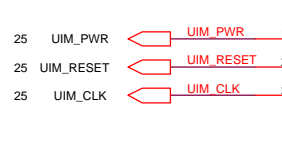

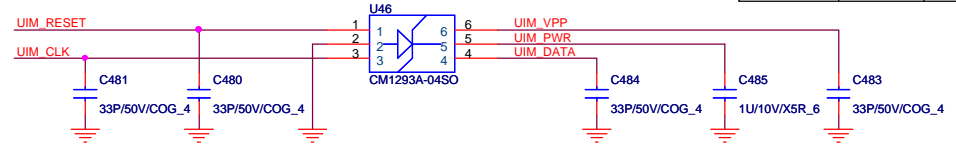

Layout Note:
 UIM_RESET, UIM_CLK, UIM_DATA routing as short as possible

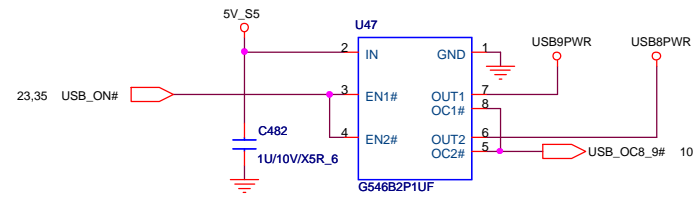
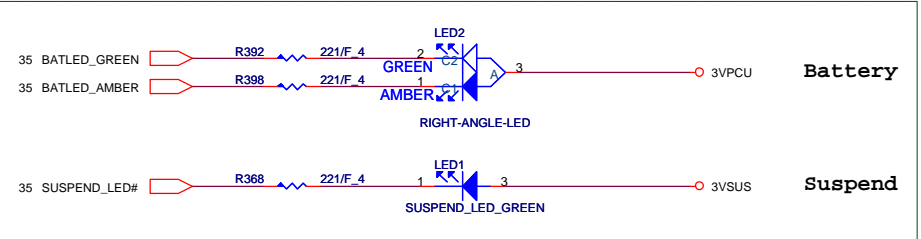

	w/ WWAN	w/o WWAN
CN29	ASM	NO ASM
U46	ASM	NO ASM
C480-C481	ASM	NO ASM
C483-C485	ASM	NO ASM

FRONT LEDs





LD-Note Calpella UMA
Quanta Computer Inc.

Size Custom	Document Number USB X2/SIM_CARD/LEDs/RF	Rev
Date: Tuesday, November 17, 2009	Sheet 24 of 46	

MiniCard WWAN connector

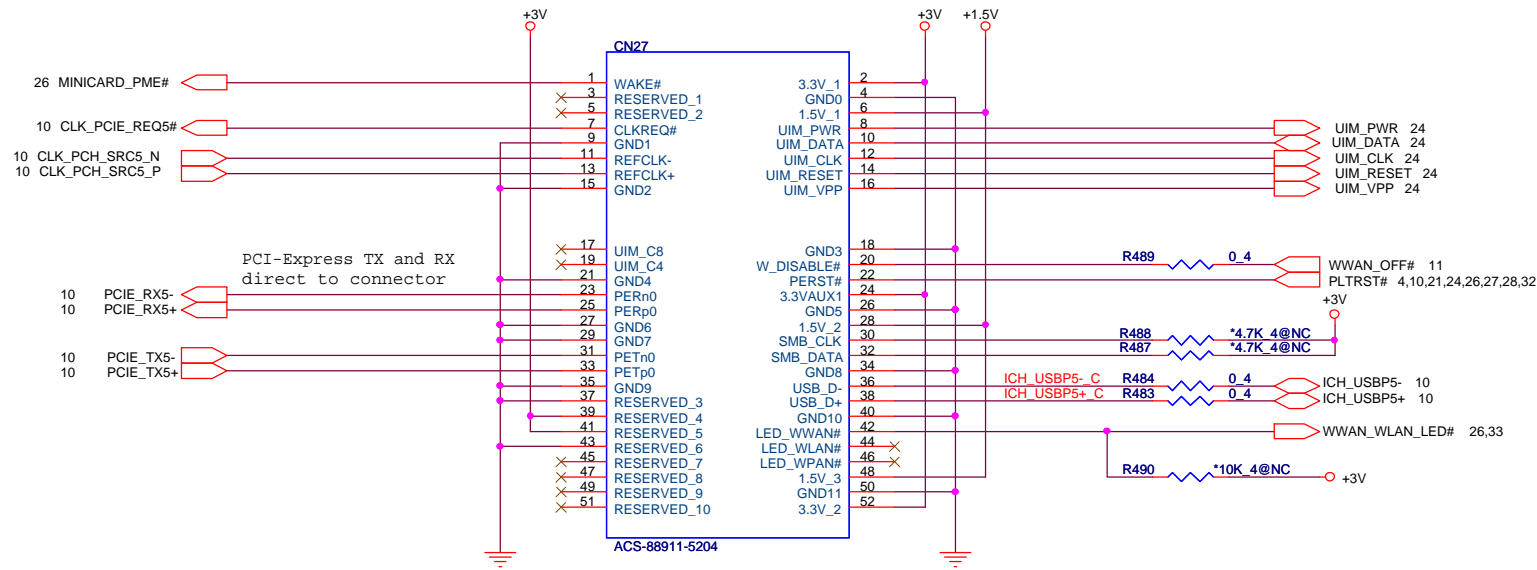

	w/ WWAN	w/o WWAN
CN27	ASM	NO ASM
R489	ASM	NO ASM
R484	ASM	NO ASM
R483	ASM	NO ASM
C1000~ C1004	ASM	NO ASM

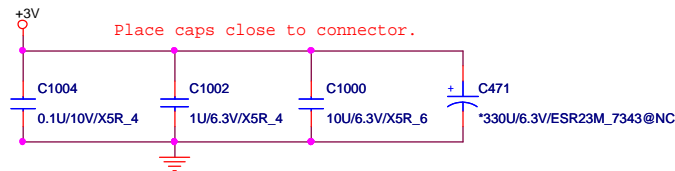
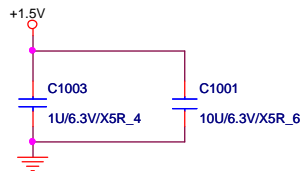
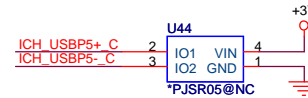

MiniCard WLAN/WiMAX connector

3,4,8,9,10,11,12,14,15,16,17,18,19,21,22,23,24,25,27,28,29,31,32,33,34,35,37,39,40,41,42
 3,25,27,39 +1.5V
 9,16,21,24,33,34,35,37,38,41,43 3VPCU
 16,37,38,39,40,41,42,43 VIN

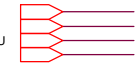

26

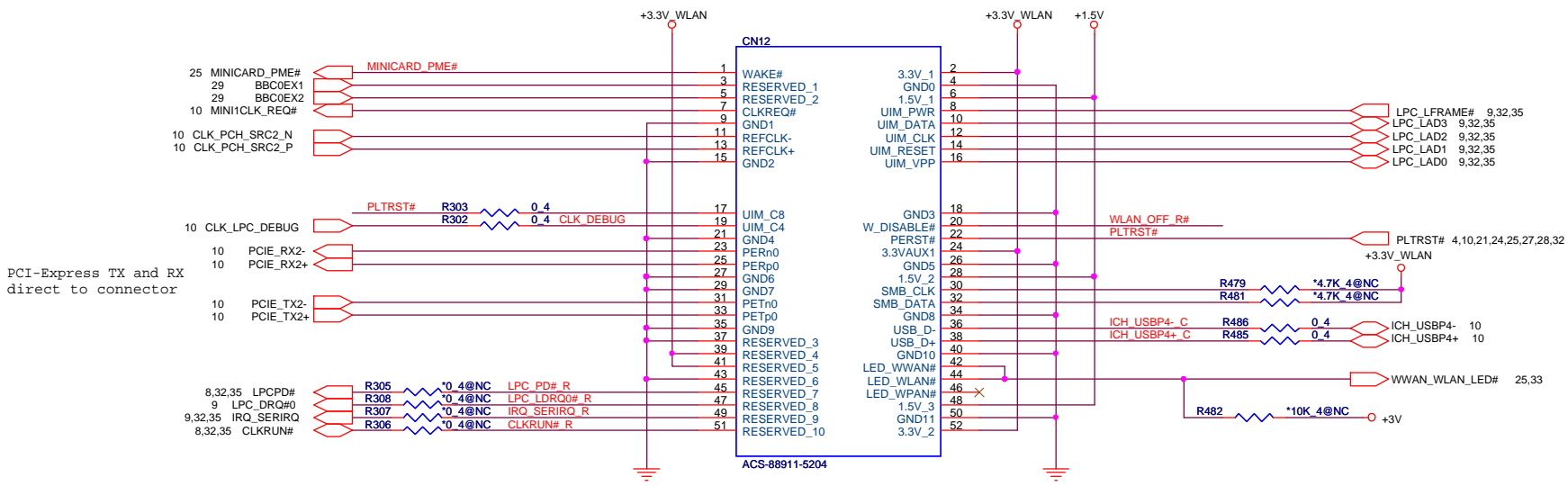

PCI-Express TX and RX direct to connector

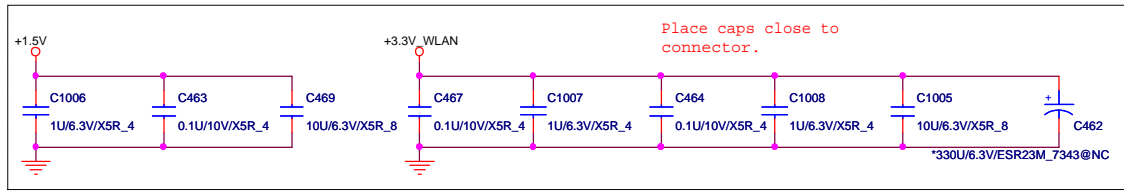
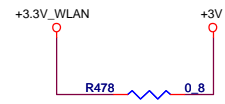
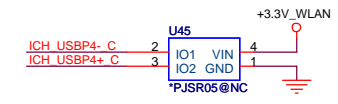
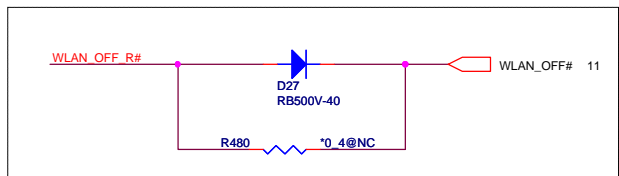
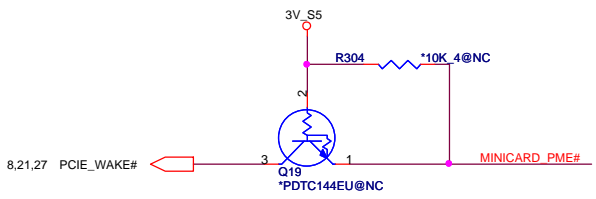



LD-Note Calpella UMA
Quanta Computer Inc.

Size Custom	Document Number MINI-Card (WLAN)	Rev
Date: Tuesday, November 17, 2009	Sheet 26 of 46	Rev

Express Card

3,4,8,9,10,11,12,14,15,16,17,18,19,21,22,23,24,25,26,28,29,31,32,33,34,35,37,39,40,41,42
 3,25,26,39 +3V
 9,24,35,37,43 +1.5V
 3VSUS

27

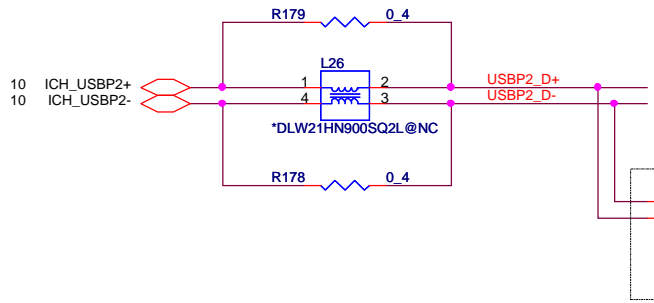

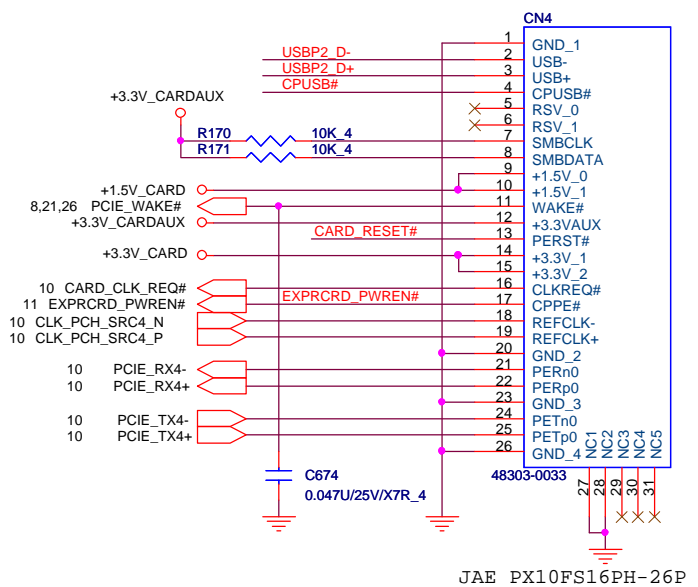
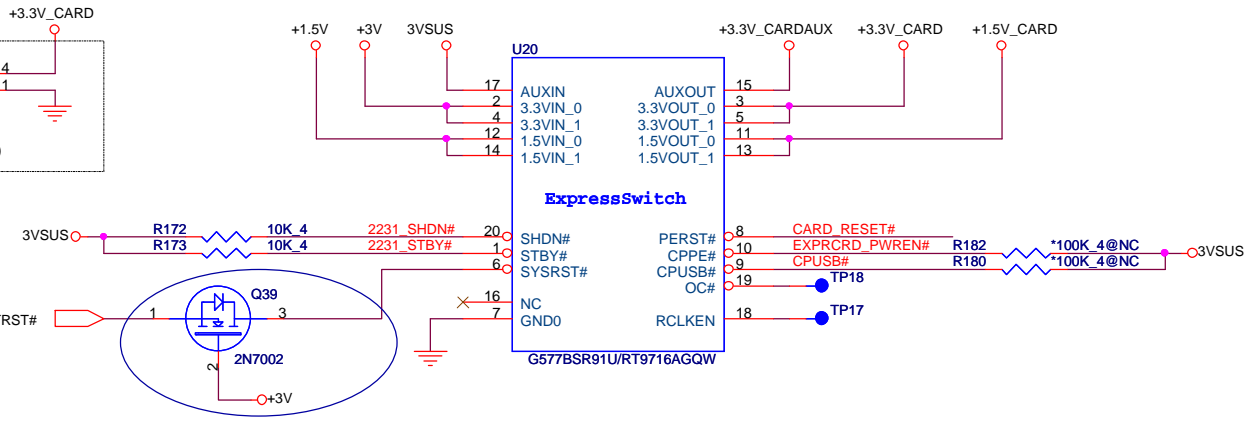

+1.5V_CARD Max. 650mA, Average 500mA.
 +3V_CARD Max. 1300mA, Average 1000mA.

20090928
 avoid current leakage

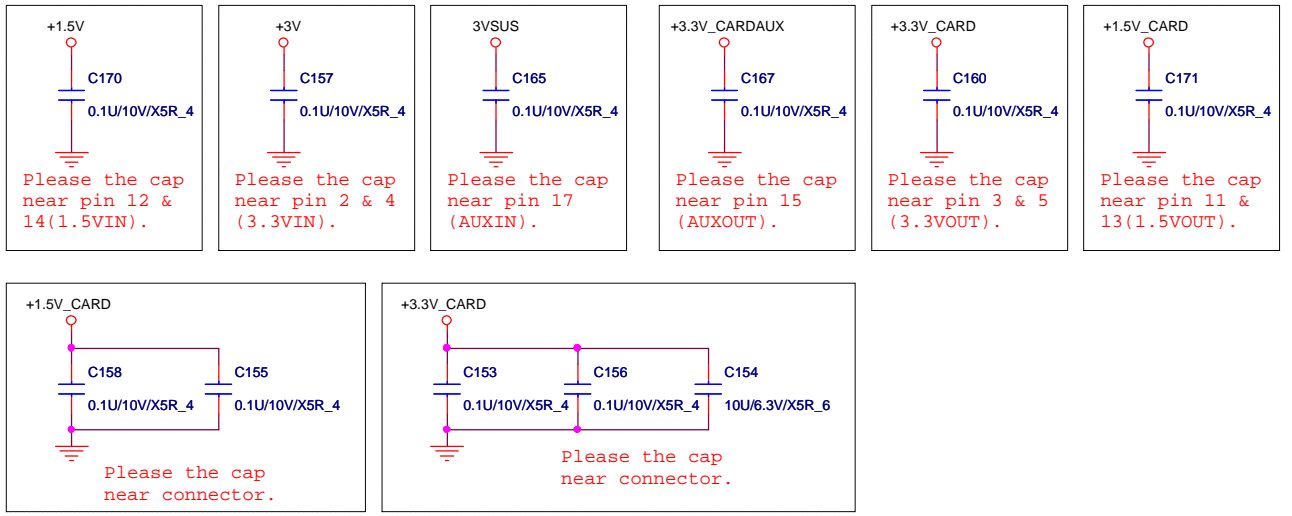

JAE PX10FS16PH-26P





LD-Note Calpella UMA
Quanta Computer Inc.

Size Custom	Document Number Express Card	Rev
Date: Tuesday, November 17, 2009	Sheet 27 of 46	

iTPM ENABLE/DISABLE



iTPM Function	R366
Enable	1K
Disable	NC

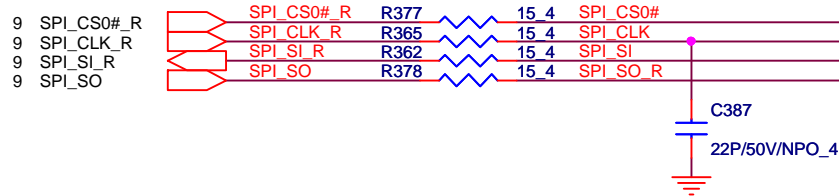

For PCH 32Mbit (4M Byte), SPI

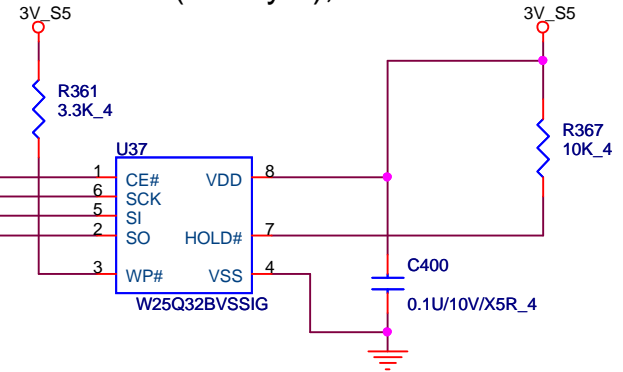

RFID

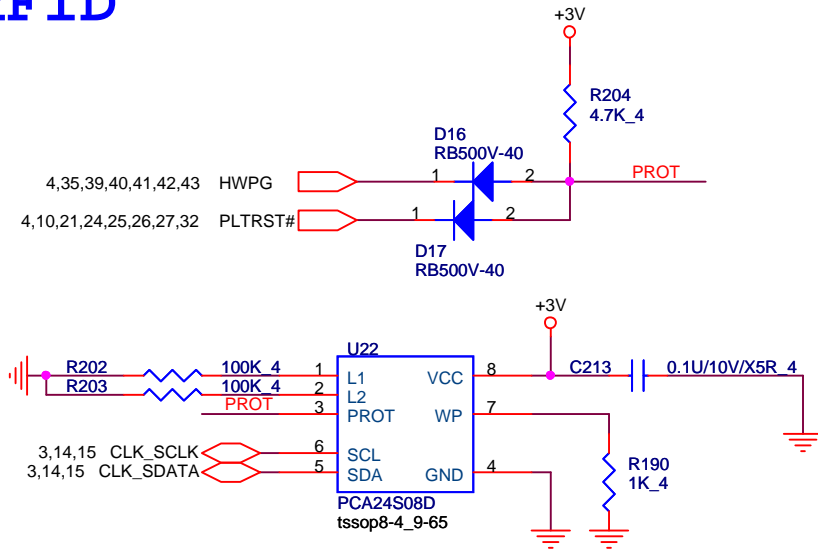

**LD-Note Calpella UMA
Quanta Computer Inc.**

Size Custom	Document Number ITPM & RFID EEPROM	Rev
Date: Tuesday, November 17, 2009	Sheet 28	of 46

BLUETOOTH

3,4,8,9,10,11,12,14,15,16,17,18,19,21,22,23,24,25,26,27,28,31,32,33,34,35,37,39,40,41,42

+3V

29

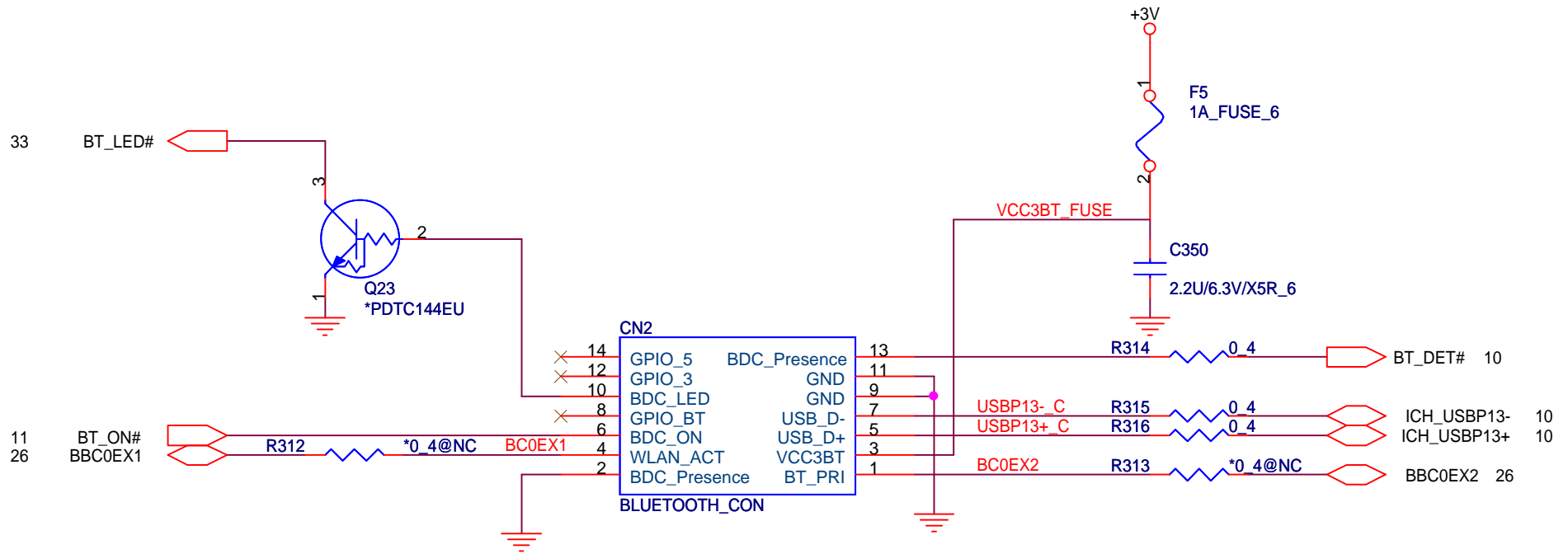

LD-Note Calpella UMA
Quanta Computer Inc.

Size Custom	Document Number B/T	Rev
Date: Tuesday, November 17, 2009	Sheet 29 of 46	

KEYBOARD

KEYBOARD connector

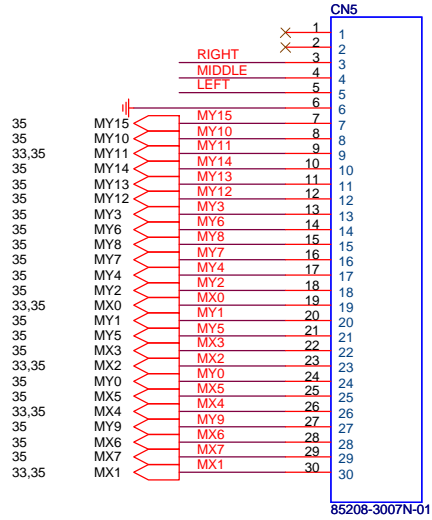

8,12,17,18,19,22,31,35,37 +5V
9,16,21,24,33,34,35,37,38,41,43 3VPCU

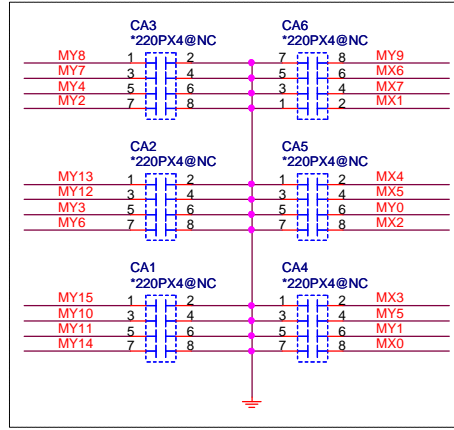

Touch pad/Track point Switch

30

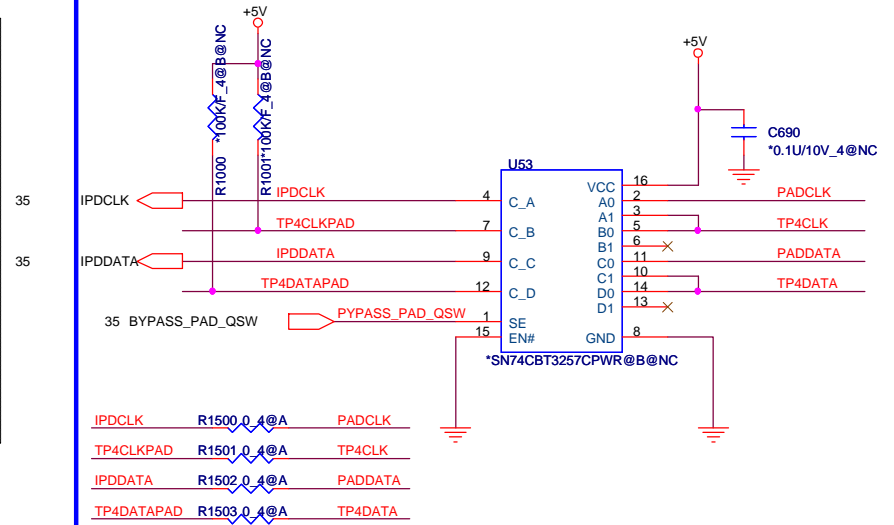

Touch pad

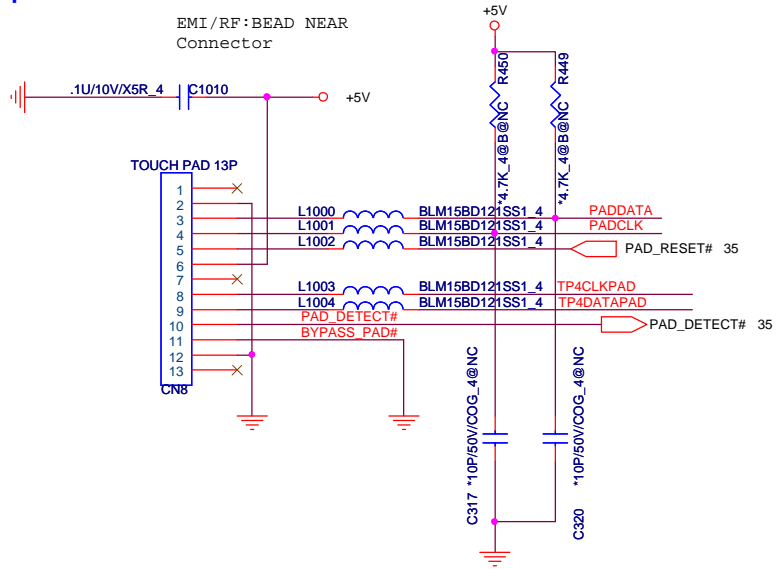

TRACK POINT

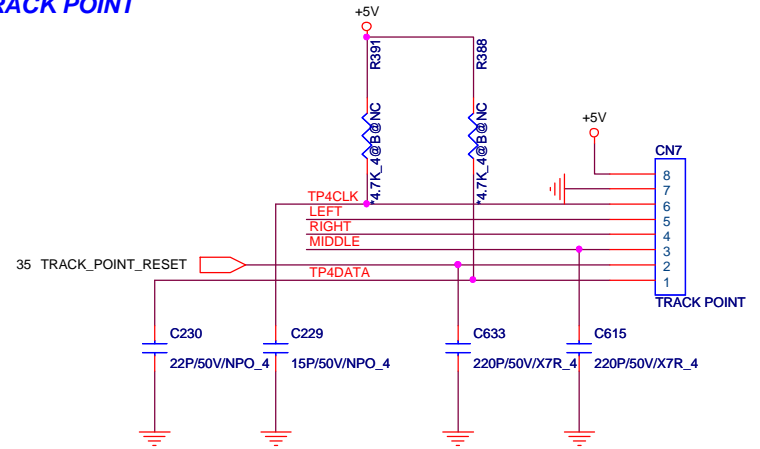



LD-Note Calpella UMA
Quanta Computer Inc.

Size Custom	Document Number K/B, T/P	Rev
Date: Tuesday, November 17, 2009		Sheet 30 of 47

FAN CONTROL

3,4,8,9,10,11,12,14,15,16,17,18,19,21,22,23,24,25,26,27,28,29,32,33,34,35,37,39,40,41,42 +3V
8,12,17,18,19,22,30,35,37 +5V

31

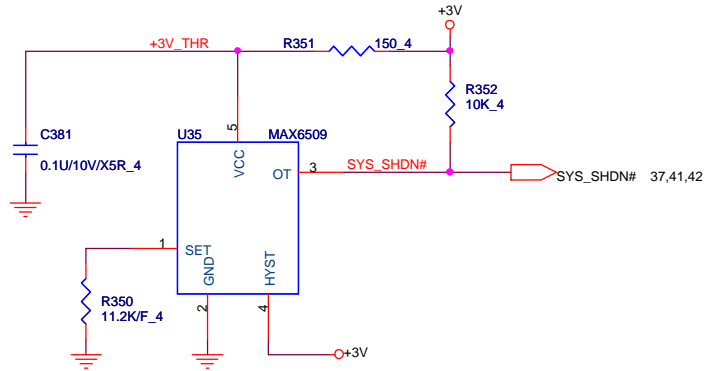
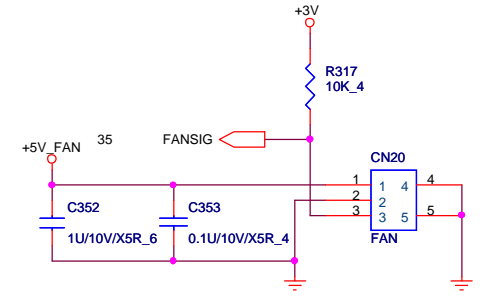
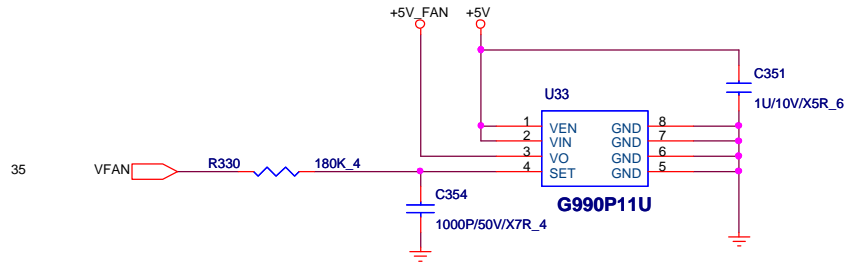

 LD-Note Calpella UMA Quanta Computer Inc.		Size	Document Number	Rev
		Custom	FAN & THERMAL	
Date: Tuesday, November 17, 2009		Sheet	31	of 46

G-SENSOR (2-Axial)

32

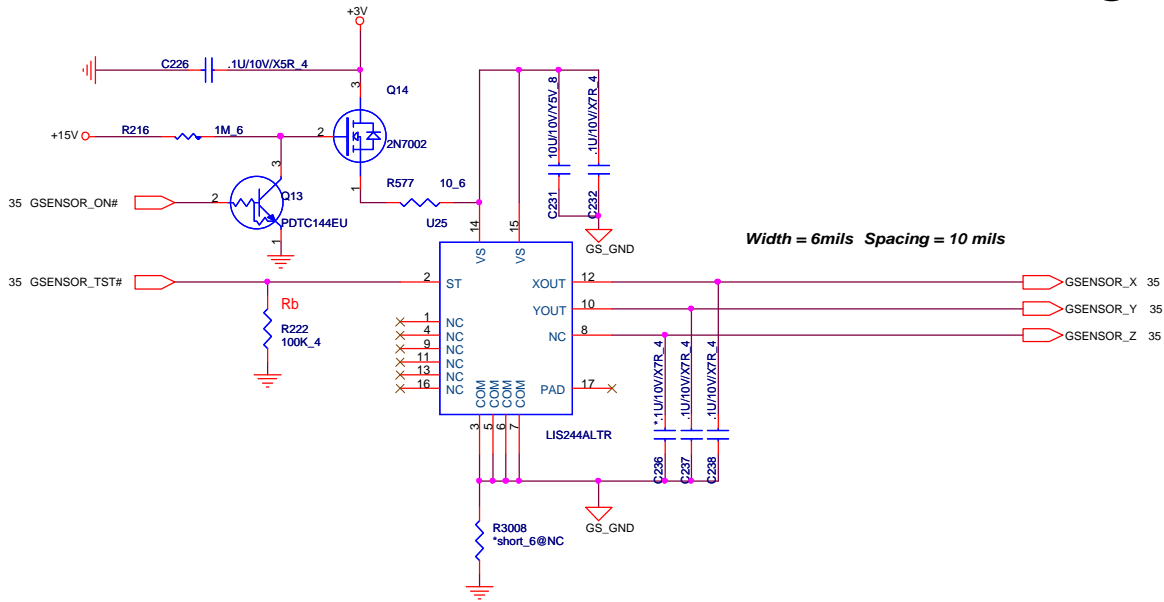

Discrete TPM

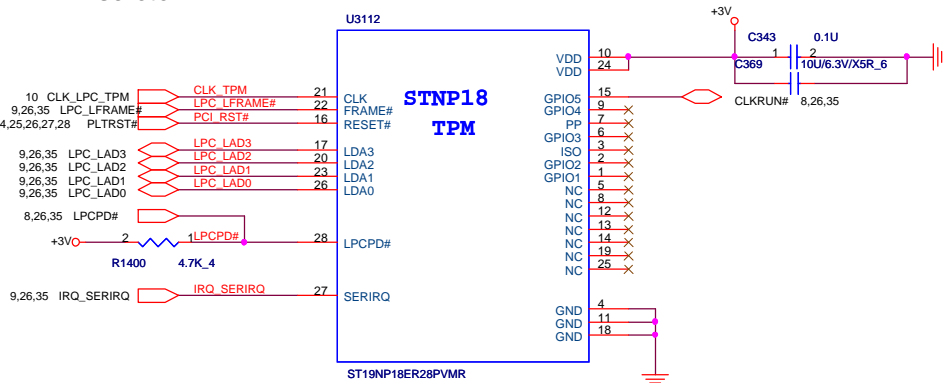

supplier P/N:ST19NP18ER28PVMR
 Quanta P/N:AL19NP18K13
 F/P:tssop28-6_4-65-1_2h

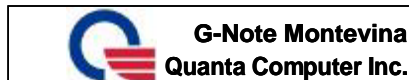

Daughter Boards for LEDs & Ports

FFC TO KBD LEFT SIDE CONNECTOR

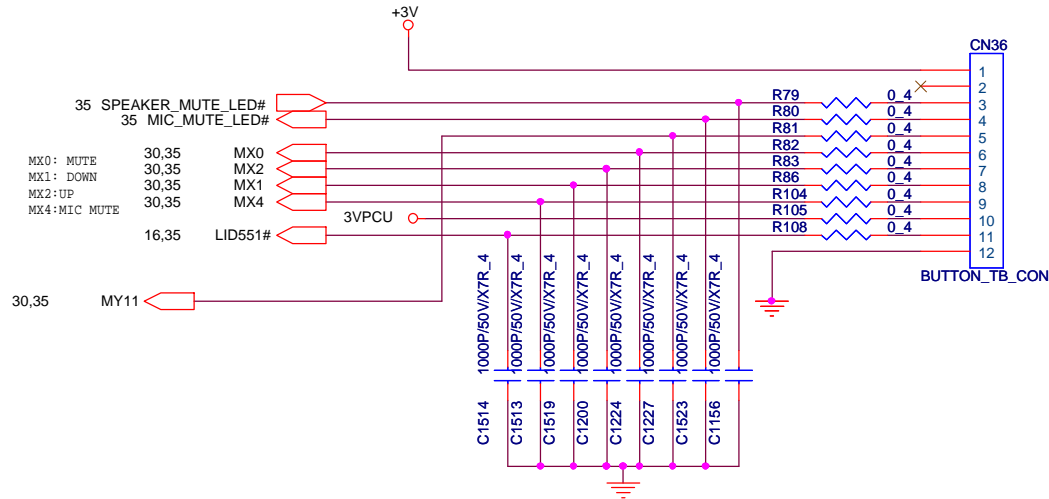

FFC TO LED RIGHT SIDE CONNECTOR

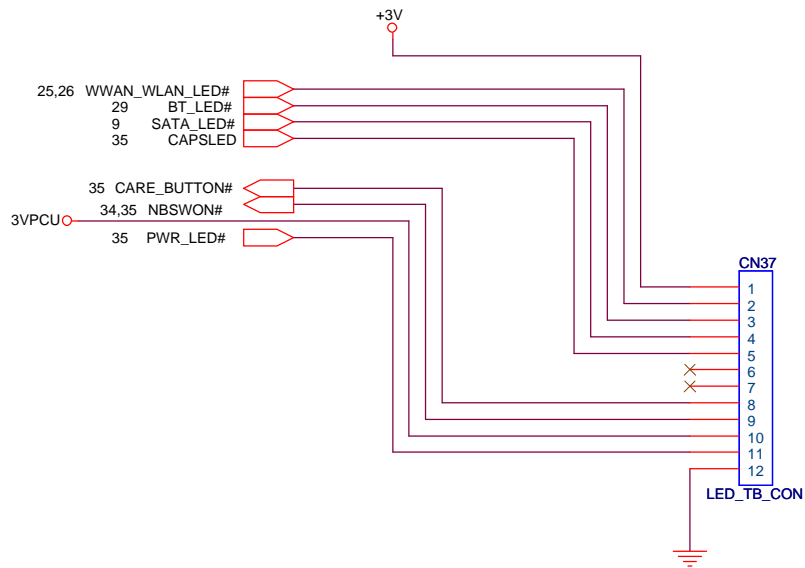

**G-Note Montevina
Quanta Computer Inc.**

Size Custom	Document Number	Rev <RevCo
Daughter Boards		
Date: Tuesday, November 17, 2009	Sheet 33 of 46	

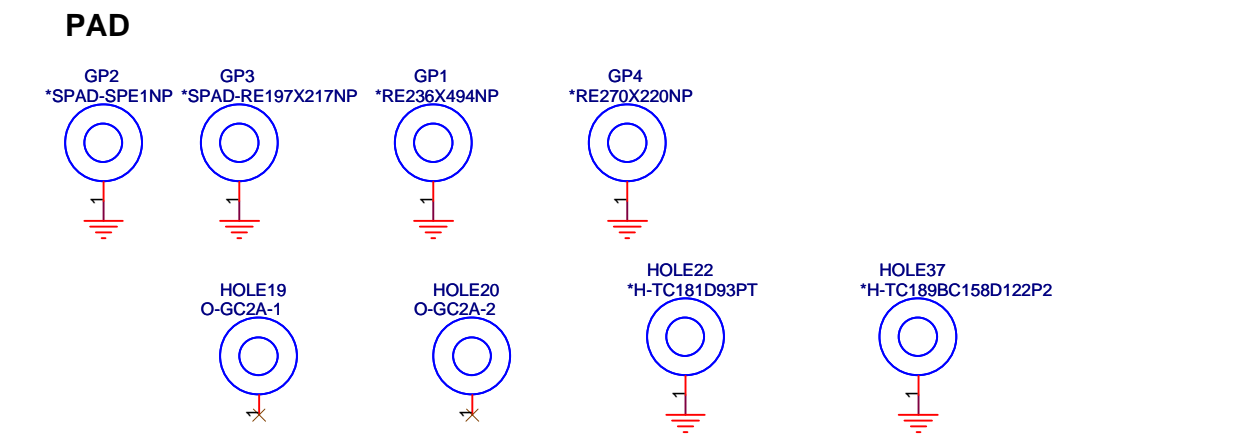
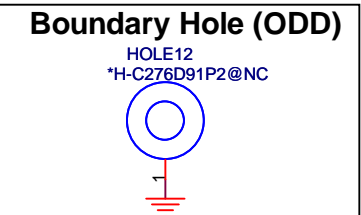
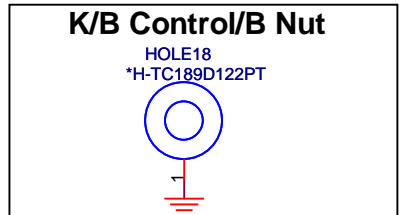
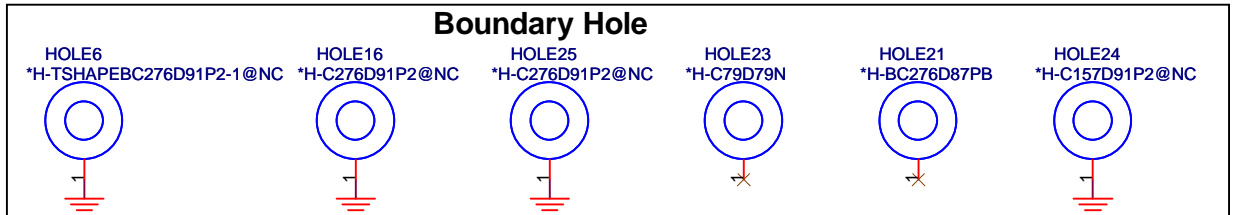
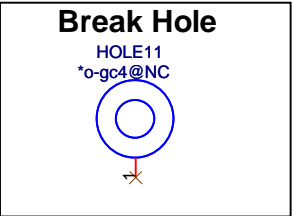
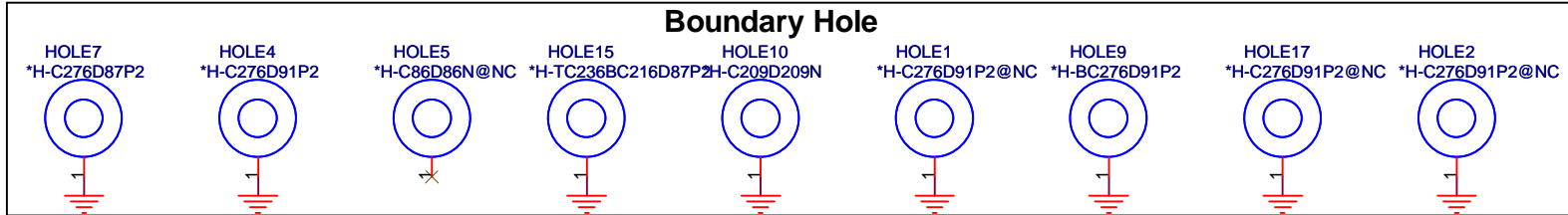
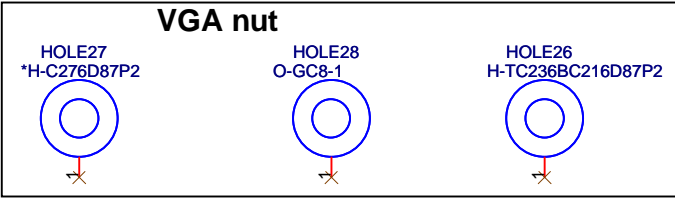
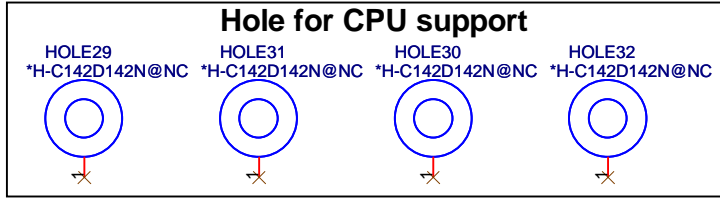
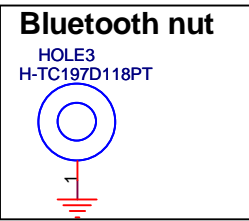
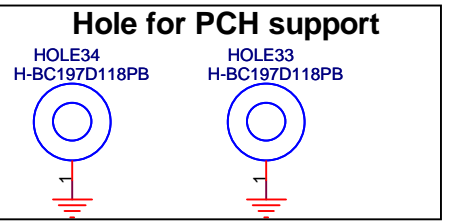
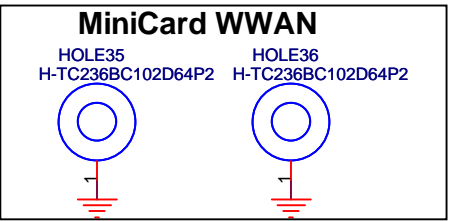
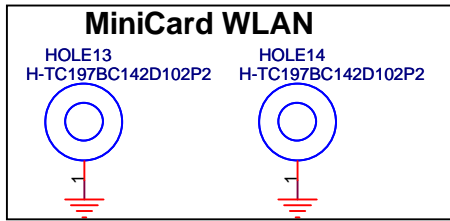

**LD-Note Calpella UMA
Quanta Computer Inc.**

Size Custom	Document Number HOLD & SKEW	Rev
Date: Tuesday, November 17, 2009	Sheet 36	of 46

+3.3V, +5V

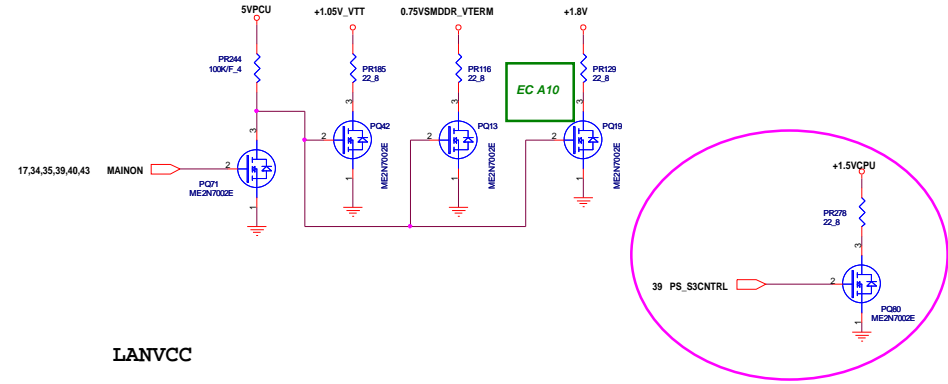
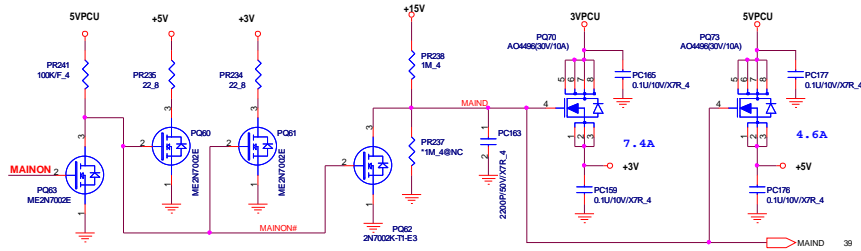

3V_S5, 5V_S5

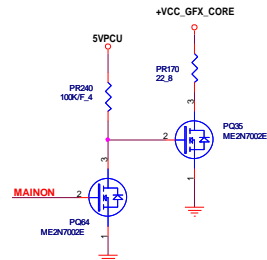
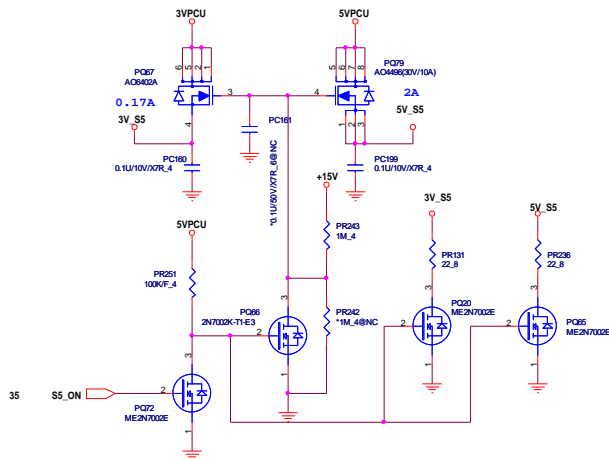

LANVCC

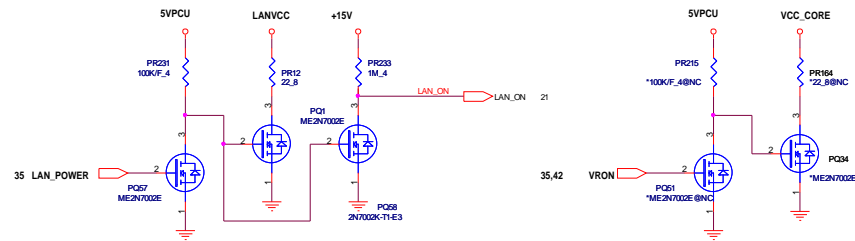

3VSUS, 5VSUS

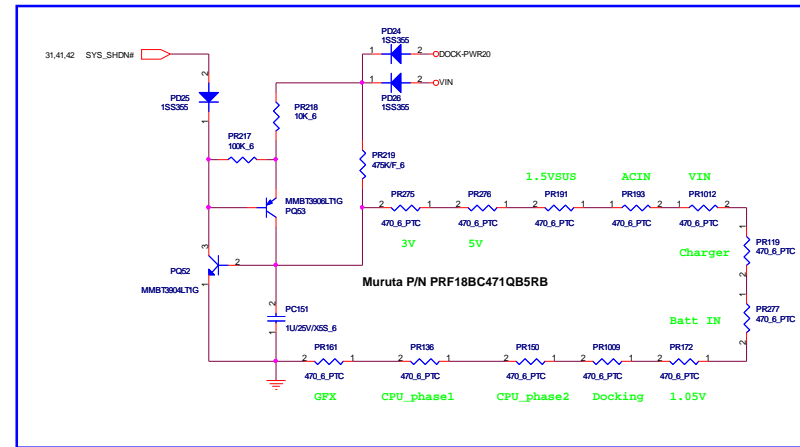
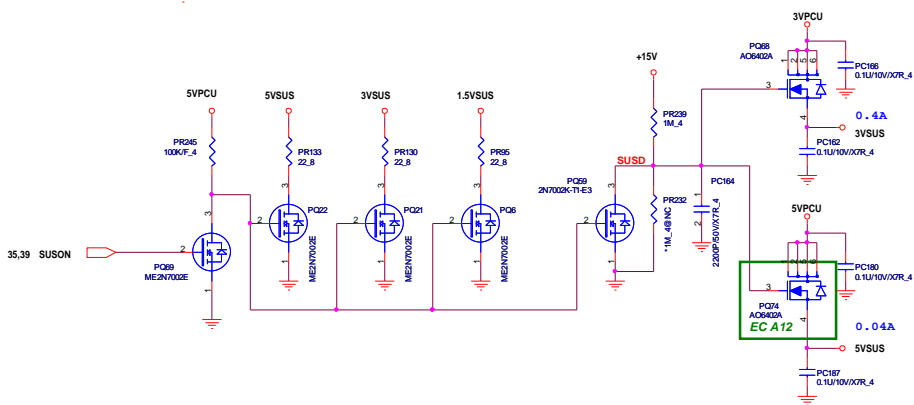

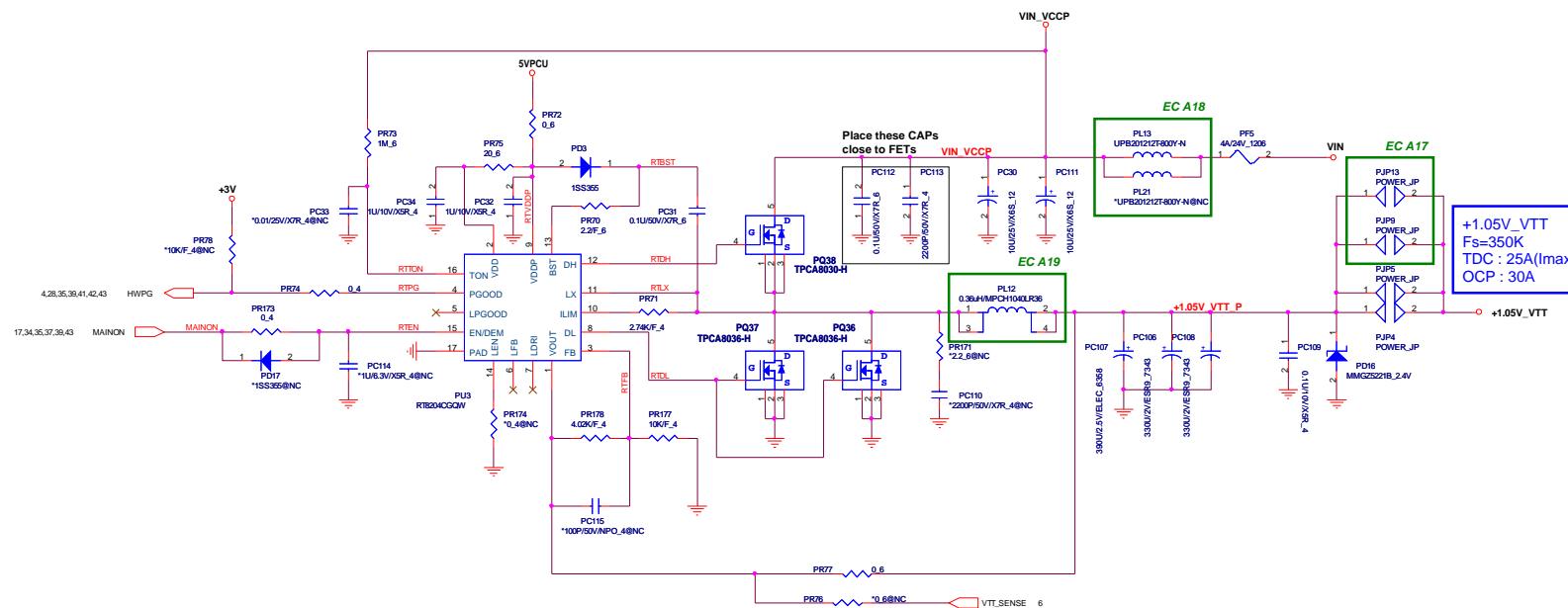

+1.05V_VTT
 Fs=350K
 TDC : 25A(I_{max})
 OCP : 30A

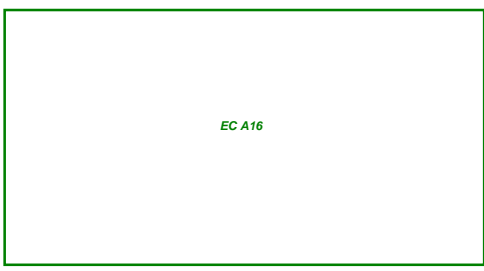

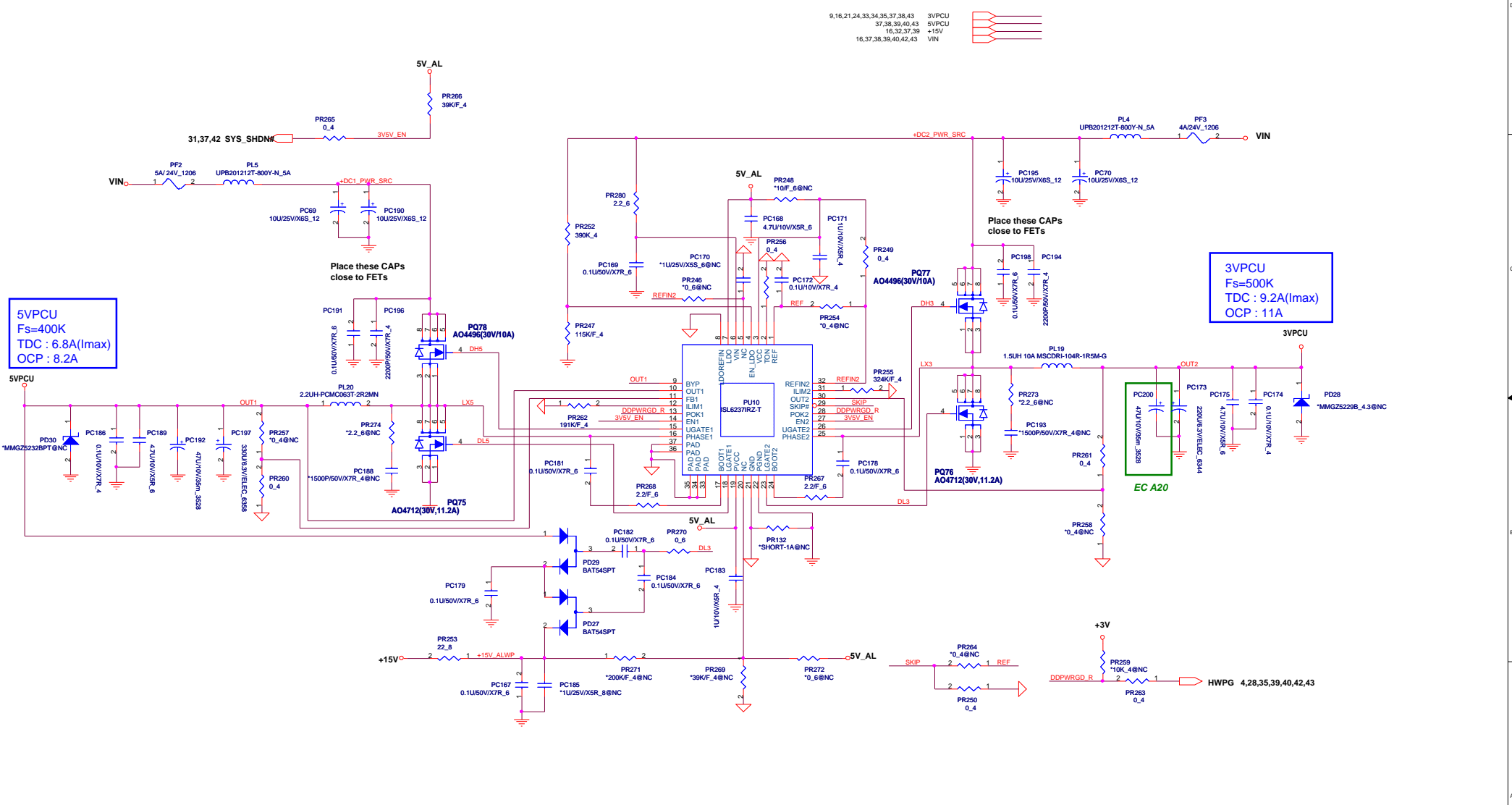

5VPCU
Fs=400K
TDC : 6.8A(I_{max})
OCP : 8.2A

3VPCU
Fs=500K
TDC : 9.2A(I_{max})
OCP : 11A

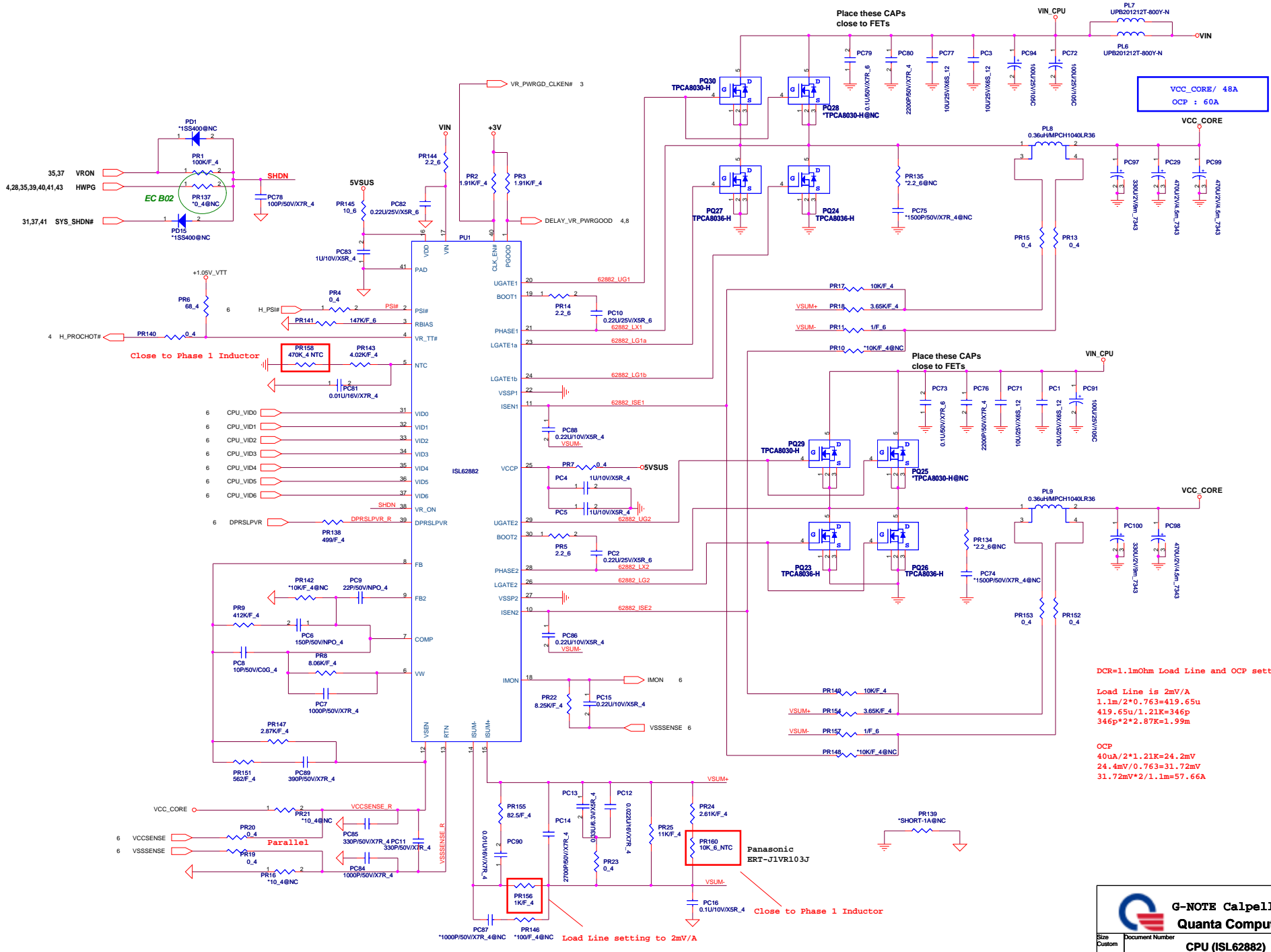

DCR=1.1mOhm Load Line and OCP setting

Load Line is 2mV/A
 $1.1m/2 * 0.763 = 41.9.65u$
 $41.9.65u / 1.21k = 34.6p$
 $346p * 2 * 2.87k = 1.99m$

OCP
 $40uA / 2 * 1.21k = 24.2mV$
 $24.4mV / 0.763 = 31.72mV$
 $31.72mV * 2 / 1.1m = 57.66A$

G-NOTE Calpella (UMA)
Quanta Computer Inc.

Doc Number: **CPU (ISL62882)**

Rev: 1B

Date: Tuesday, November 17, 2009 Sheet: 42 of 46

Load Line setting to 2mV/A

Close to Phase 1 Inductor

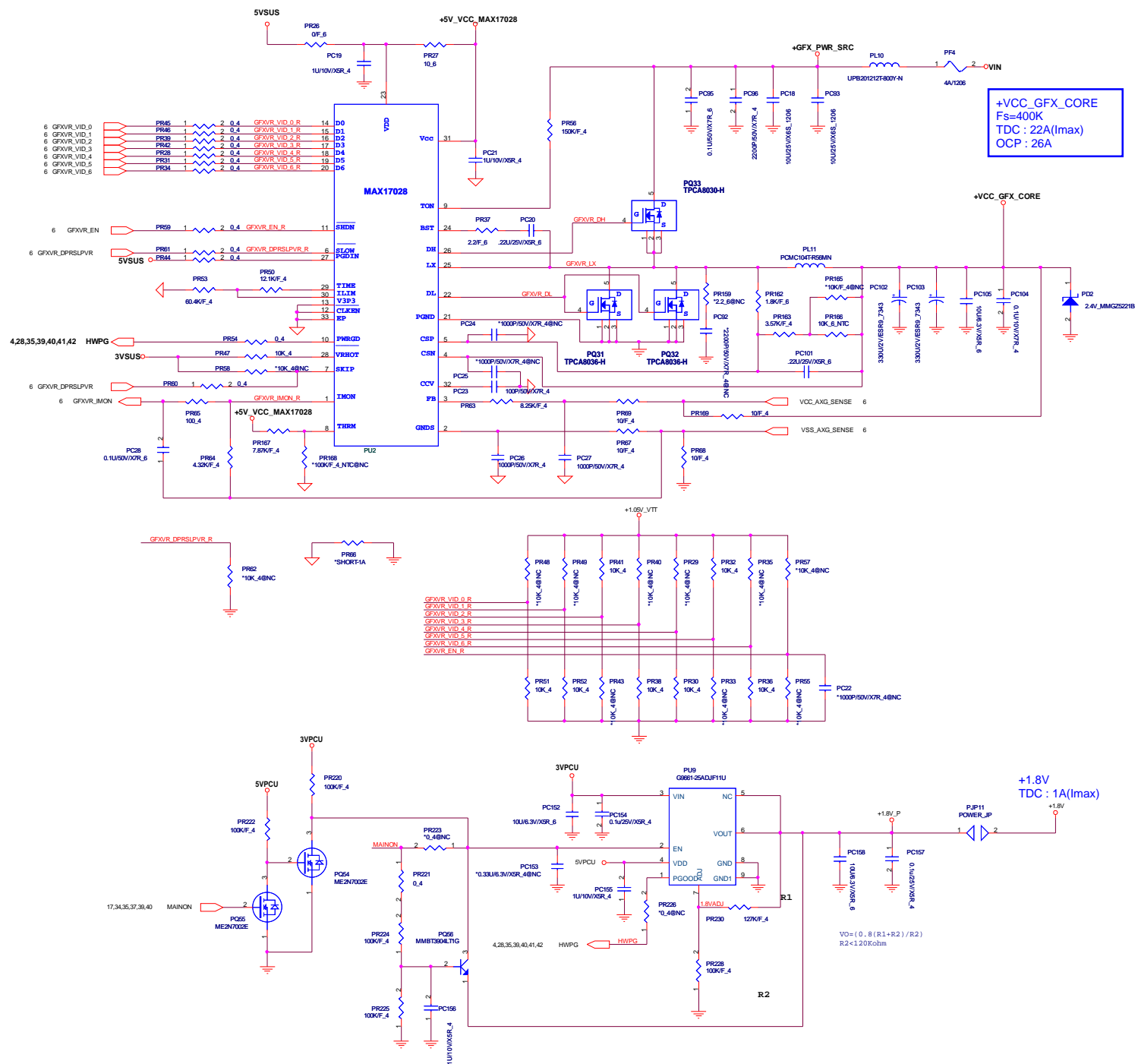

Revision History

Revision	Date	Phase	Change List	Release Schematic Date	Release Gerber File Date
1A		DV	Initial release		

Schematic Value Explanation Description :

RESISTOR

Value	F	4	6	8	12	1210	*	Description
*1K/F_4	1%	0402 (1005)					DE POP	1K ohm 1% SMD 0402 package and DE POP
1K_6	5%		0603 (1608)				POP	1K ohm 5% SMD 0603 package and POP
1K_8	5%			0805 (2125)			POP	1K ohm 5% SMD 0805 package and POP
1K_12	5%				1206 (3216)		POP	1K ohm 5% SMD 1206 package and POP
1K_1210	5%					1210 (3225)	POP	1K ohm 5% SMD 1210 package and POP

CAPACITOR

Value	Voltage	Material	6				*	Description
*0.1U/10V/X5R_4	10V	X5R	0402 (1005)				DE POP	0.1UF 10V X5R SMD 0402 package DE POP
1U/25V/X7R_6	25V	X7R	0603 (1608)				POP	0.1UF 25V X7R SMD 0603 package POP



LD-Note Calpella UMA
Quanta Computer Inc.

Size	Document Number	Revision	Rev
Custom	Revision & Schematic Value Description		
Date:	Tuesday, November 17, 2009	Sheet	44 of 46

