

# Y Note-5 Block Diagram

04211-2 SOVP  
39T0344\_J81230

## PCB Layer Stackup

- L1:Top
- L2:GND
- L3:Signal 1
- L4:Signal 2
- L5:GND
- L6:VCC
- L7:Signal 3
- L8:Signal 4
- L9:GND
- L10:Bottom

## System DC/DC

MAX1901 62	
INPUTS	OUTPUTS
VINT16	VCC5M
	VCC3M

## Battery Charger/Selector

MAX8724 57	
CV16	M-BAT-PWR
	S-BAT-PWR
VINT16	VCCIR05B
	VCCIR5M

## GMCH/ICH6 CORE

MAX1540 66	
VINT16	VCCIR05B
	VCCIR5M
VINT16	VCCIR05B
	VCCIR5M

## CPU DC/DC

ISL6217 63	
VINT16	VCCCPUCORE
VINT16	VCCCPUCORE

## DDR2 DC/DC

MAX1993 65	
VINT16	VCCIR8M
VINT16	VCCIR8M

## LVDS/DDR2\_VREF

MAX1589/LP2996MR 67	
VCC3M	VCC2R5A
VCC3M	VCC0R9B
VCC3M	VCC0R9B

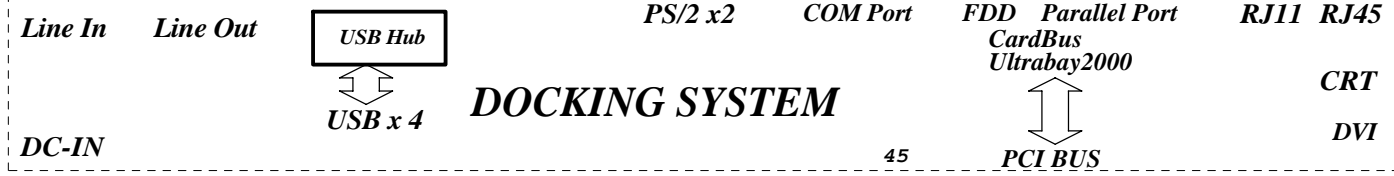
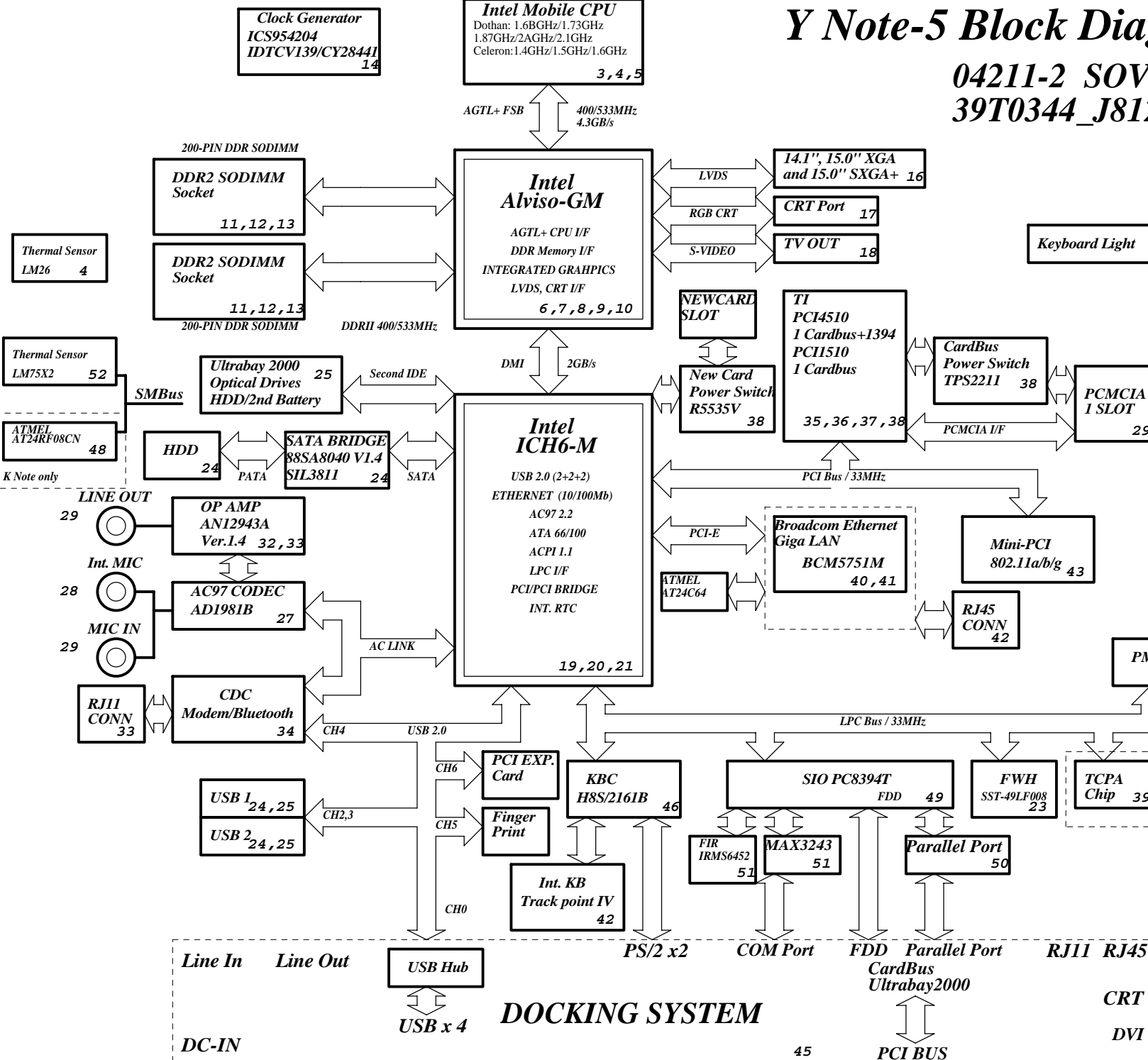

緯創資通 Wistron Corporation  
21F, 88, Sec.1, Hsin Tai Wu Rd., Hsichih, Taipei Hsien 221, Taiwan, R.O.C.

Title			Block Diagram		
Size	Document Number	Y Note-5		Rev	-2
A3					
Date:	Wednesday, December 29, 2004	Sheet	1	of	71

### RESISTOR

Symbol name	Value	Tolerance (J: 5%, F: 1%, D: 0.5%, B: 0.1 %)	Rating 0402=> 1/16W, 25V 0603 => 1/16W, 75V 0805 => 1/10W, 100V	Size 2=>0402, 3=>0603, 5=>0805, 6=>1206, 0=>1210
10KR3	10K Ohm	If no letter, it means J: 5%	1/16W, 75V	0603
33D3R5	33.3 Ohm	If no letter, it means J: 5%	1/10W, 100V	0805
1KR3F	1K Ohm	F: 1%	1/16W, 75V	0603

The naming rule is value + R + size + tolerance  
 For the value, it can be read by the number before R. (R means resistor)  
 For the tolerance, it can be read from the last letter.  
 For the rating, we don't show on the symbol name.  
 For the size, R2=>0402, R3=>0603, R5=>0805,....

### PCI TABLE

DEVICE	IDSEL	IRQ(Default)	REQ# / GNT#
MINIPCI SLOT	AD18	F, G	REQ# 2/ GNT#2
CARDBUS R5C841	AD16	SERIRQ	REQ#0 / GNT#0
USB UHCI	AD29	A, B, C, D	
USB 2.0 EHCI	AD29	A	
DMI-to-PCI AC97 Modem AC97 Audio	AD30	B	REQ#1 / GNT#1
LPC Bridge IDE SATA SMBus	AD31	A B B	
PCI Express	AD28	A, B, C, D	
Azalia Controller	AD27	A	

### CAPACITOR

Symbol name	Value	Tolerance (M: +/-20, K: +/-10, Z: +80/-20)	Rating	Size 2=>0402, 3=>0603, 5=>0805, 6=>1206, 0=>1210
SCD1U10V2MX-1	0.1uF	M/X5R	10V	0402
SC10U6D3V5MX	10uF	M/X5R	6.3V	0805
SC2D2U16V5ZY	2.2uF	Z/Y5V	16V	0805

The naming rule is  
 Capacitor type + value + rating + size + tolerance + material  
 SCD1U10V2MX-1  
 SC=> SMT Ceramic, TC=> POS cap or SP cap  
 D1U => 0.1uF  
 10V => the voltage rating is 10V  
 2=> 0402, 3=>0603, 5=>0805  
 M=>tolerance M, K, Z  
 X=> X7R/X5R, Y=> Y5V  
 -1 => symbol version, nonsense to EE characteristic

### PLANAR\_ID[3...0]

PLANAR ID	3	2	1	0
GPIO	15	12	11	10
SDV	0	0	0	0
SDV-R	0	0	0	1
SIV	0	0	1	0
SIT	0	0	1	1
SIT-R	0	1	0	0
SVT	0	1	0	1
SOVP	1	1	1	1

**緯創資通** Wistron Corporation  
 21F, 88, Sec.1, Hsin Tai WJ Rd., Hsichih,  
 Taipei Hsien 221, Taiwan, R.O.C.

Title		<b>Reference</b>	
Size A3	Document Number	Rev -2	
Date: Tuesday, December 28, 2004		Sheet 2 of 71	

	Y-NOTE	K-NOTE
R645	NO_ASM	NO_ASM
R647	NO_ASM	NO_ASM

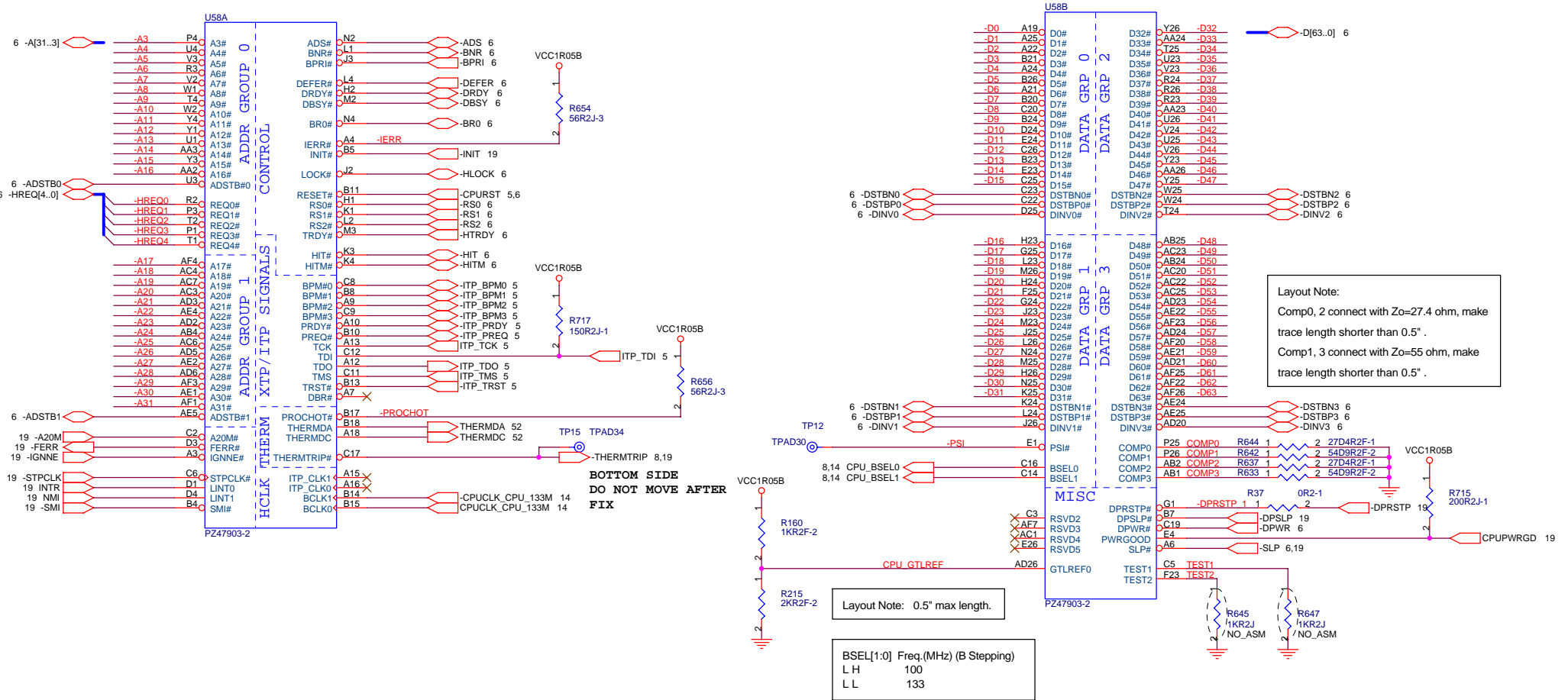

**緯創資通 Wistron Corporation**  
21F, 88, Sec.1, Hsin Tai Wu Rd., Hsichih, Taipei Hsien 221, Taiwan, R.O.C.

Title: **CPU (1/2)**

Size A3 Document Number **Y Note-5** Rev -2

Date: Tuesday, December 28, 2004 Sheet 3 of 71

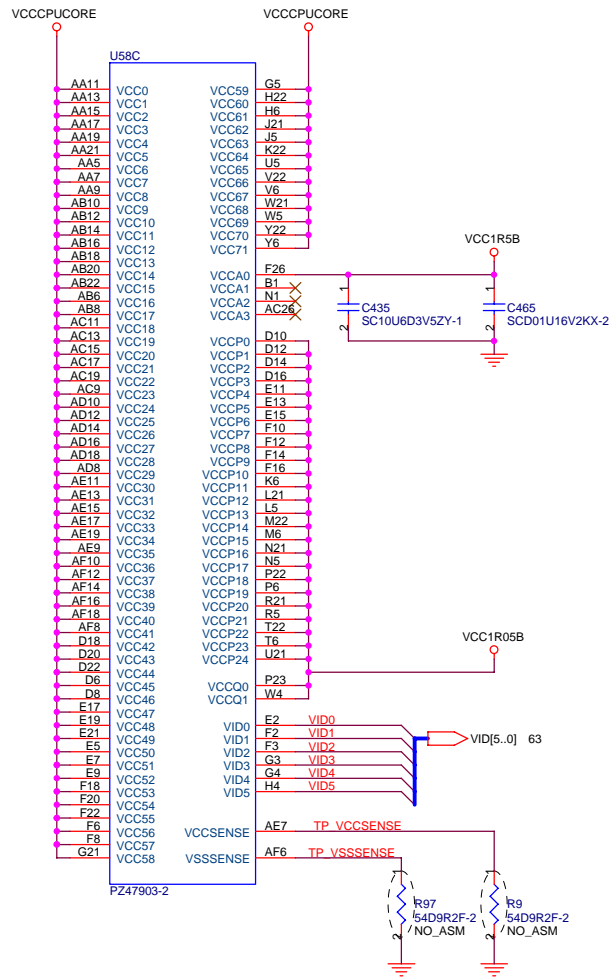

	Y-NOTE	K-NOTE
R97	NO_ASM	NO_ASM
R99	NO_ASM	NO_ASM

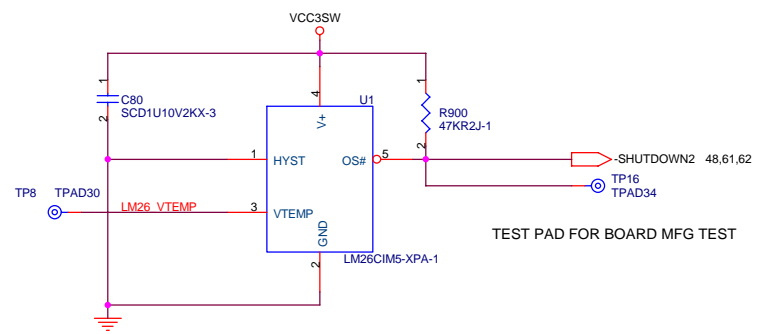
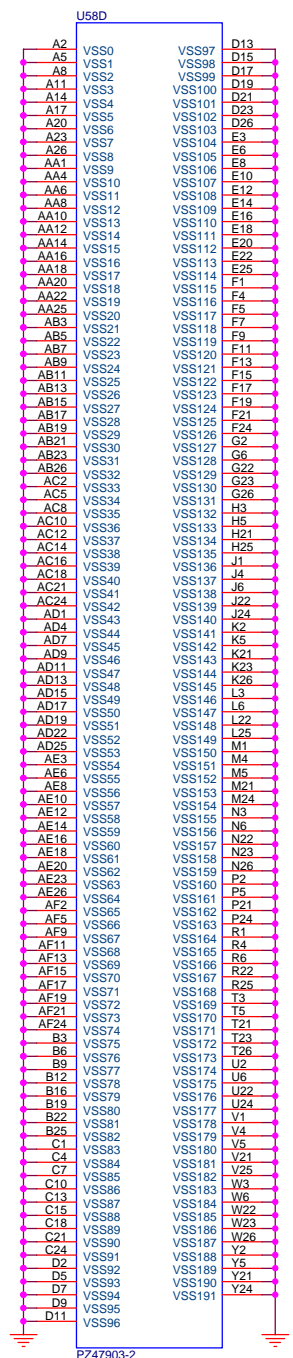

**緯創資通 Wistron Corporation**  
 21F, 88, Sec.1, Hsin Tai Wu Rd., Hsichih,  
 Taipei Hsien 221, Taiwan, R.O.C.

---

Title: **CPU (2/2)**

Size A3 Document Number: **Y Note-5** Rev: **-2**

Date: Tuesday, December 28, 2004 Sheet 4 of 71

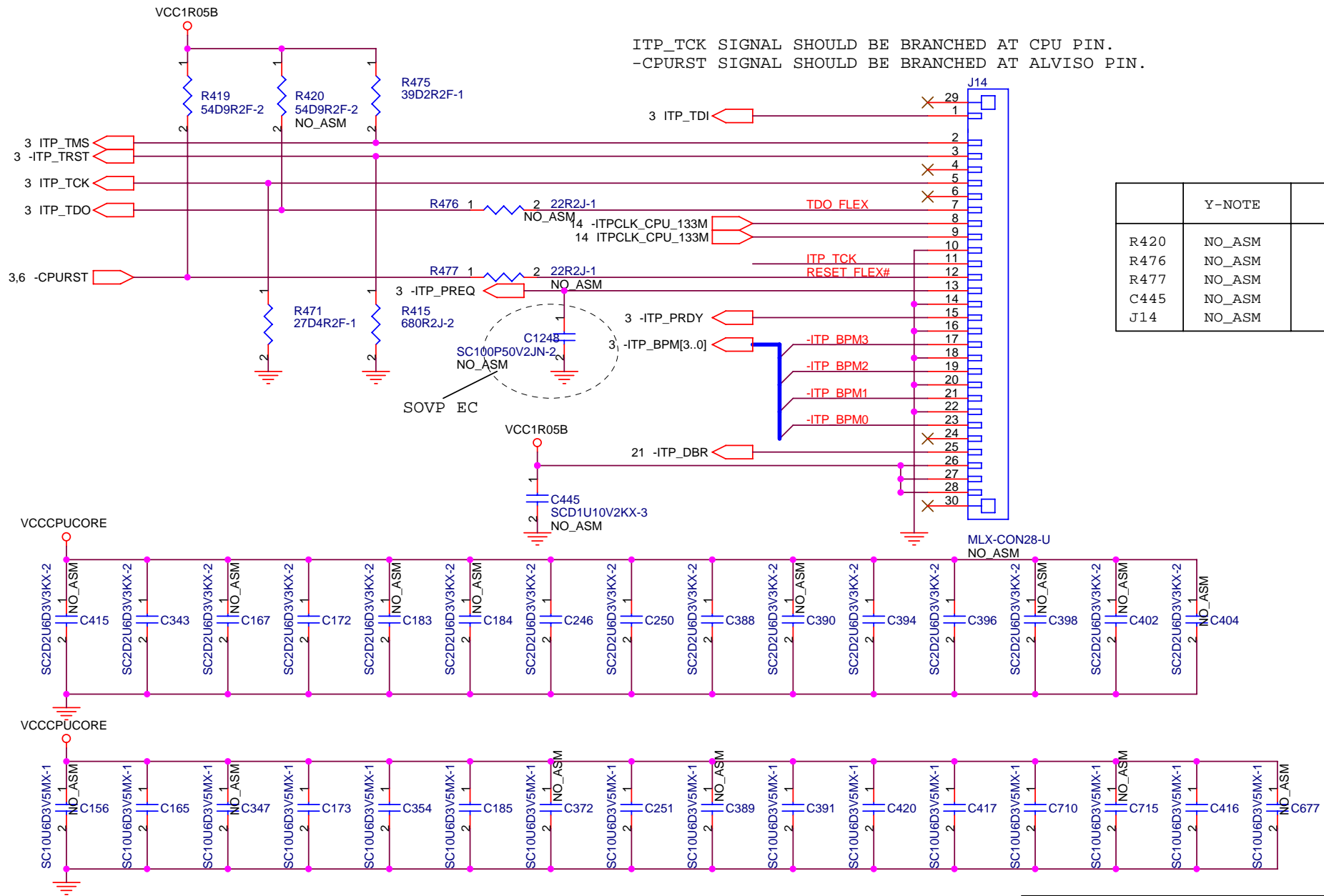

	Y-NOTE	K-NOTE
R420	NO_ASM	NO_ASM
R476	NO_ASM	NO_ASM
R477	NO_ASM	NO_ASM
C445	NO_ASM	NO_ASM
J14	NO_ASM	NO_ASM



**Wistron Corporation**  
 21F, 88, Sec.1, Hsin Tai Wu Rd., Hsichih,  
 Taipei Hsien 221, Taiwan, R.O.C.

---

Title **ITP CCONNECTOR**

Size A4	Document Number <b>Y Note-5</b>	Rev -2
------------	------------------------------------	-----------

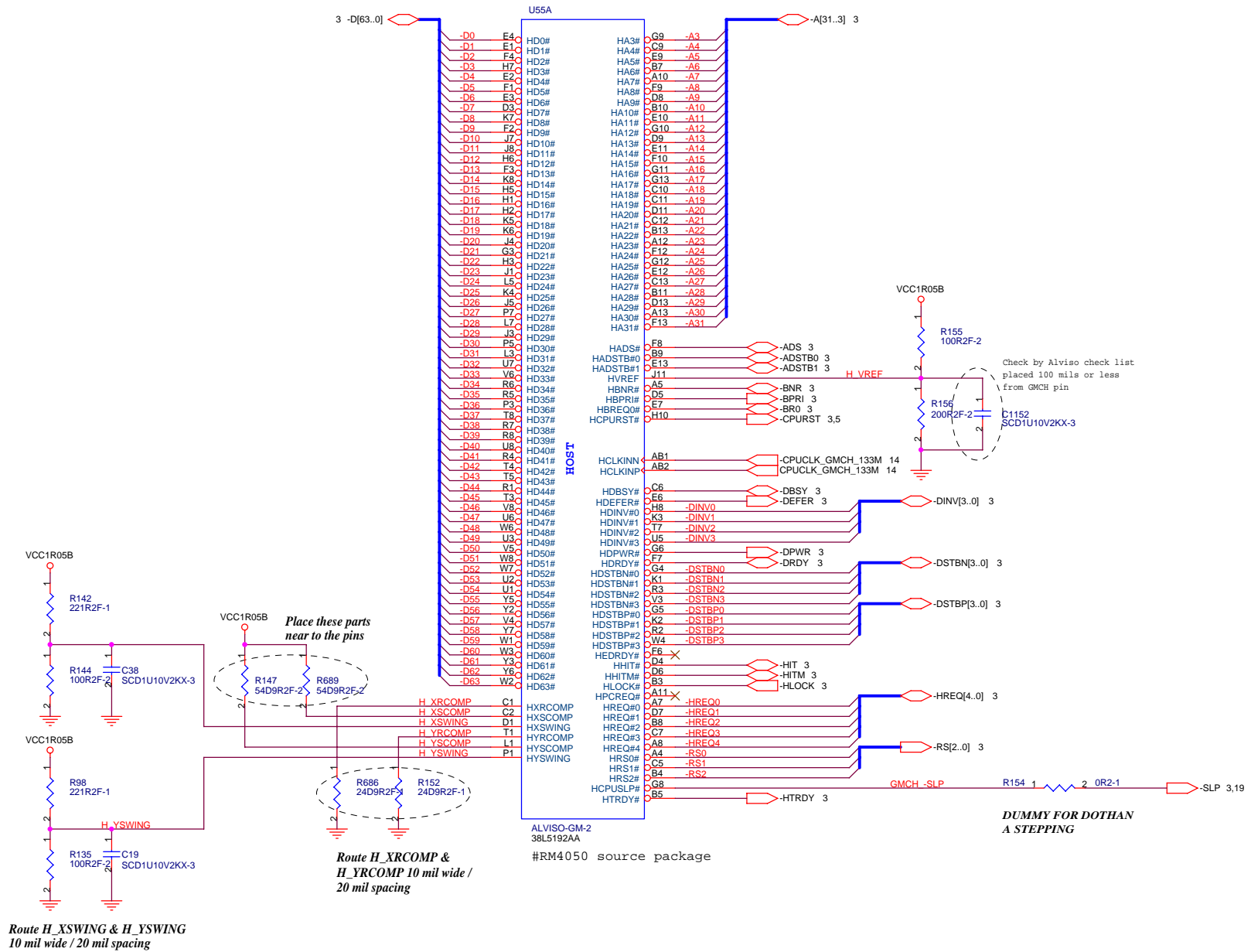
Date: Tuesday, December 28, 2004      Sheet 5 of 71



Route H\_XSWING & H\_YSWING  
10 mil wide / 20 mil spacing

Route H\_XRCOMP &  
H\_YRCOMP 10 mil wide /  
20 mil spacing

Place these parts  
near to the pins

DUMMY FOR DOTHAN  
A STEPPING

緯創資通 Wistron Corporation  
21F, 88, Sec.1, Hsin Tai Wu Rd., Hsichih,  
Taipei Hsien 221, Taiwan, R.O.C.

Title		
<b>GMCH (1/5) : HOST I/F</b>		
Size	Document Number	Rev
A3	Y Note-5	-2
Date:	Tuesday, December 28, 2004	Sheet 6 of 71

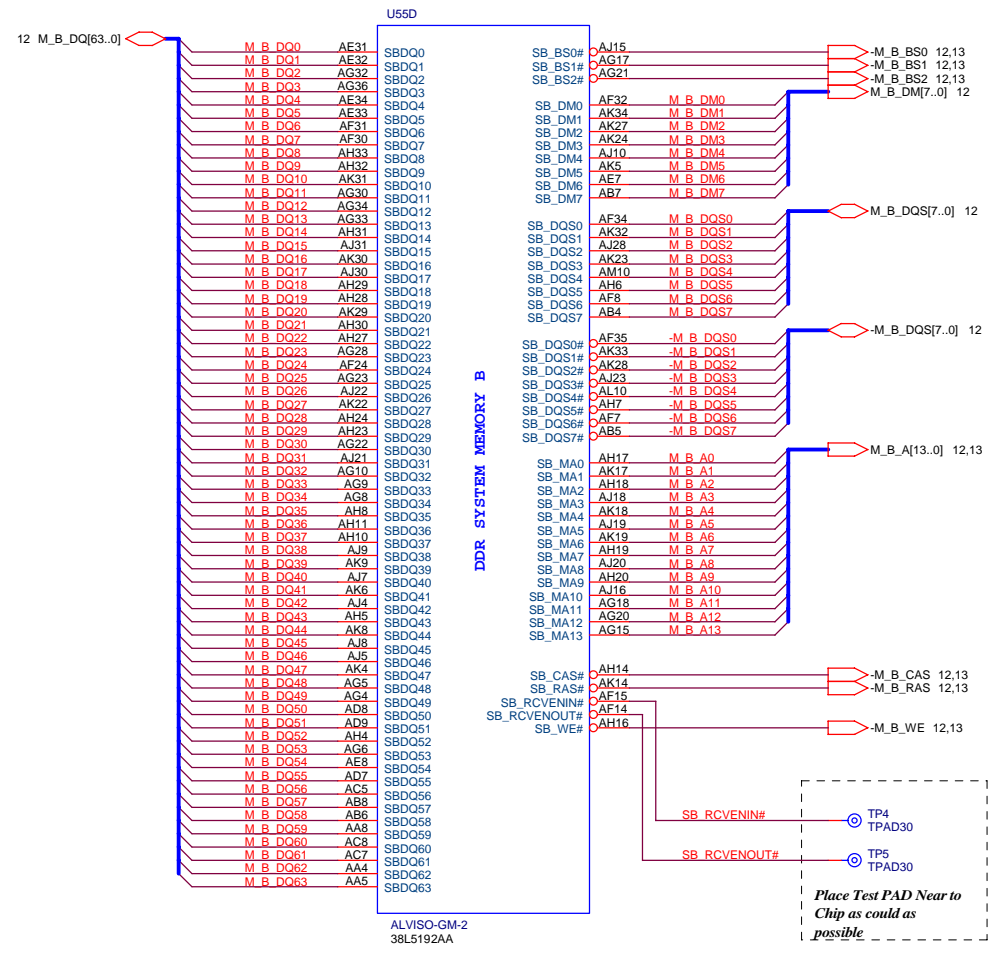
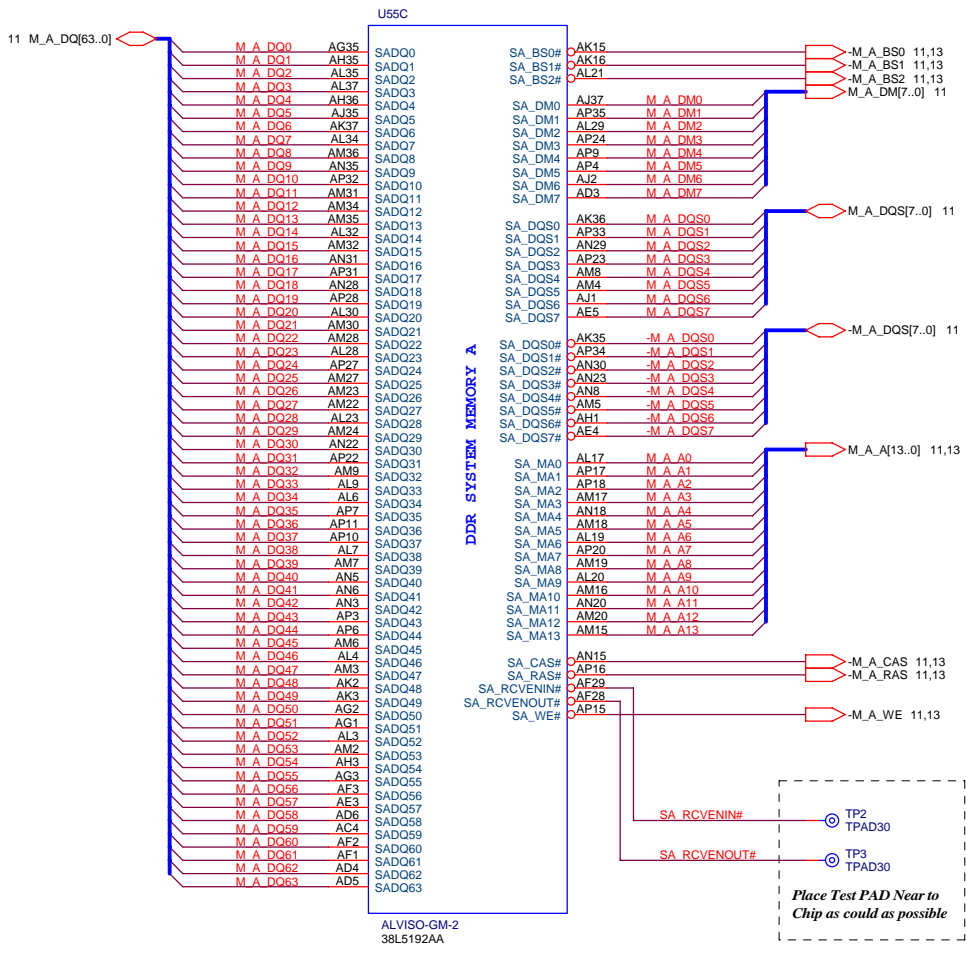

<b>緯創資通 Wistron Corporation</b>	
21F, 88, Sec.1, Hsin Tai Wu Rd., Hsichih, Taipei Hsien 221, Taiwan, R.O.C.	
Title	
<b>GMCH (2/5) : MEMORY</b>	
Size	Document Number
A3	<b>Y Note-5</b>
Date:	Rev
Tuesday, December 28, 2004	-2
Sheet	of
7	71

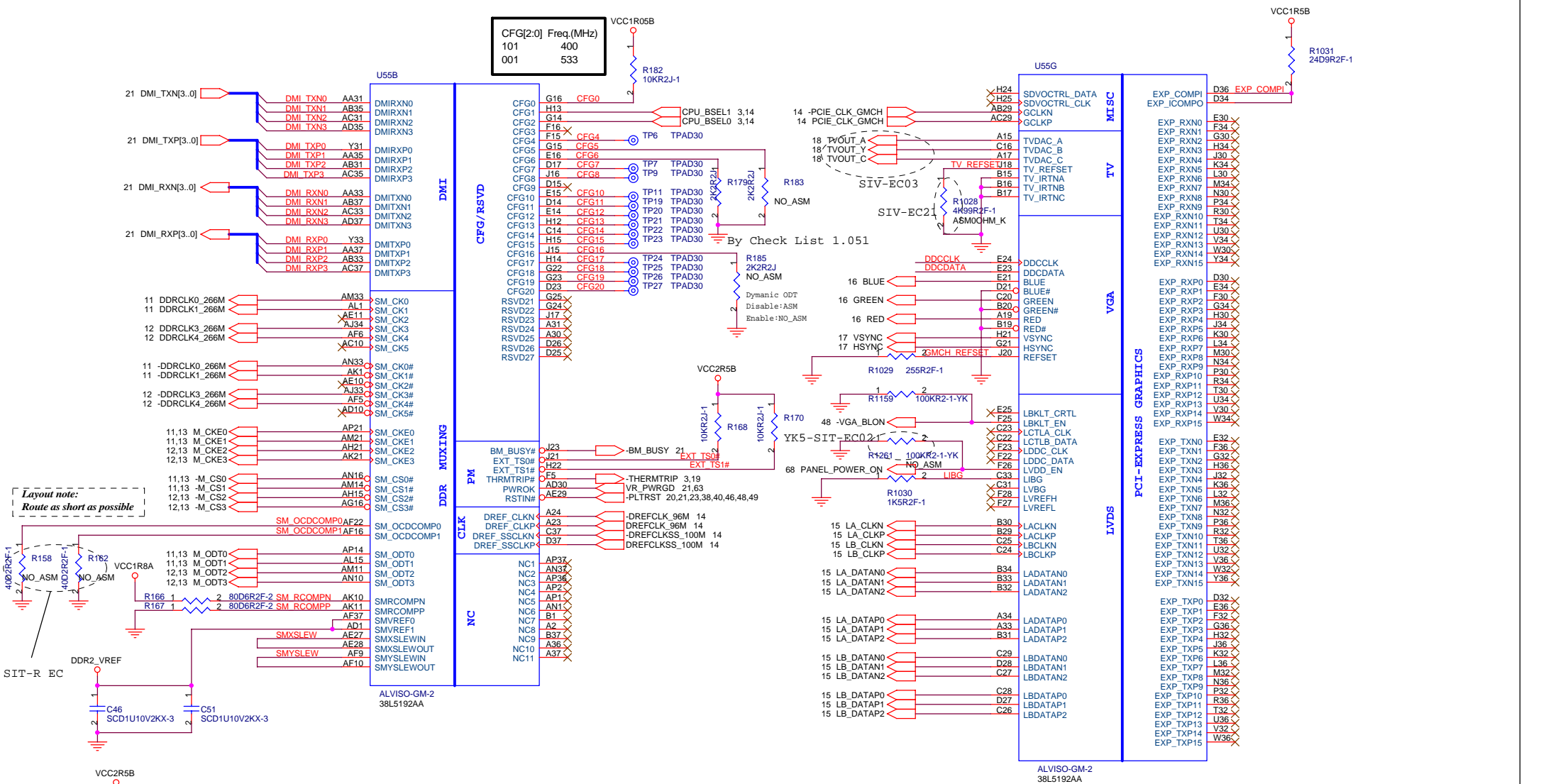

	Y-NOTE	K-NOTE
R183	NO_ASM	NO_ASM
R185	NO_ASM	NO_ASM
R1028	4K99R	0R2

**緯創資通 Wistron Corporation**  
21F, 88, Sec.1, Hsin Tai Wu Rd., Hsichih, Taipei Hsien 221, Taiwan, R.O.C.

Title: **GMCH(3/5) : VIDEO**

Size A3 Document Number: **Y Note-5** Rev -2

Date: Tuesday, December 28, 2004 Sheet 8 of 71



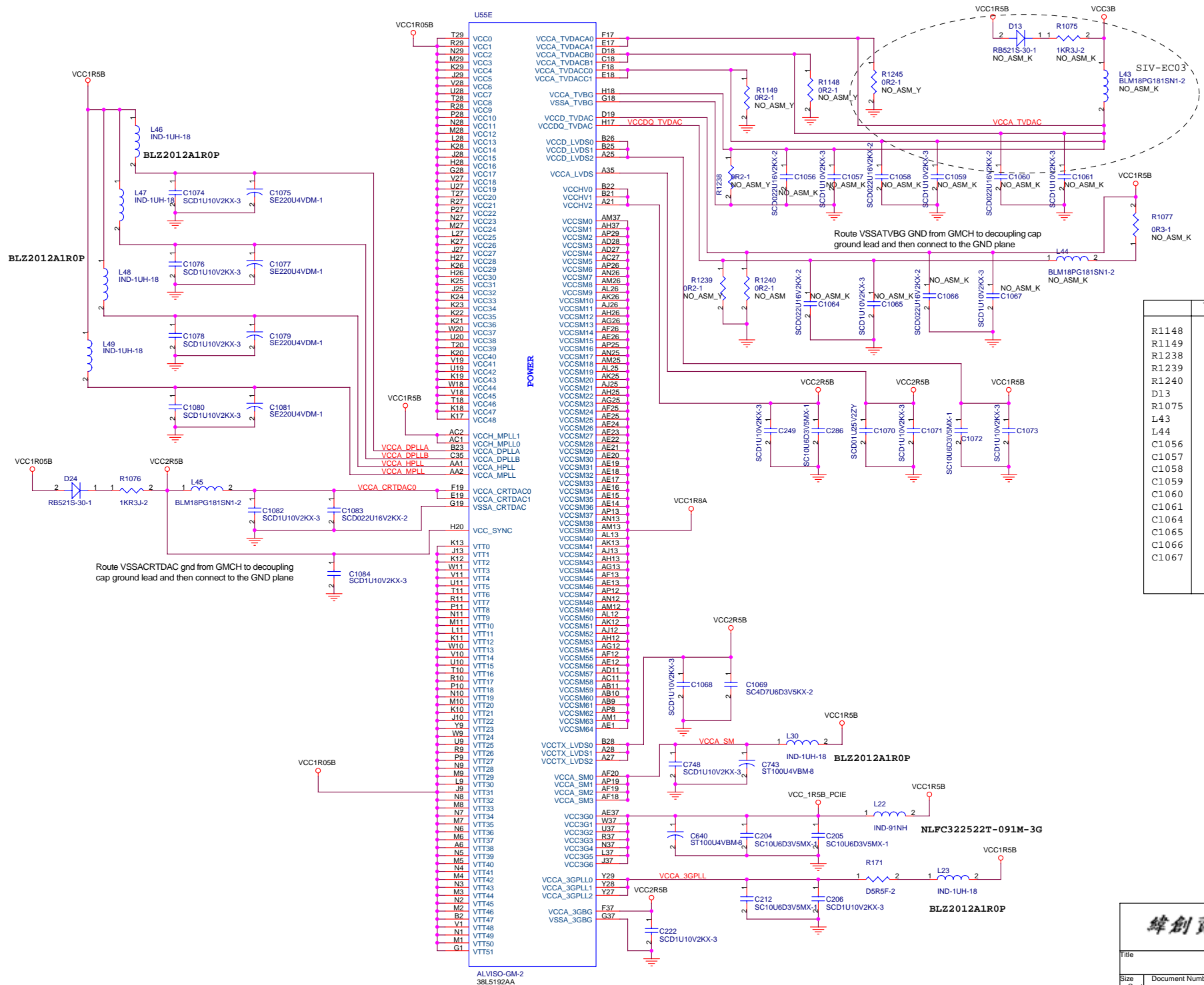

	Y-NOTE	K-NOTE
R1148	NO_ASM	ASM
R1149	NO_ASM	ASM
R1238	NO_ASM	ASM
R1239	NO_ASM	ASM
R1240	NO_ASM	ASM
D13	ASM	NO_ASM
R1075	ASM	NO_ASM
L43	ASM	NO_ASM
L44	ASM	NO_ASM
C1056	ASM	NO_ASM
C1057	ASM	NO_ASM
C1058	ASM	NO_ASM
C1059	ASM	NO_ASM
C1060	ASM	NO_ASM
C1061	ASM	NO_ASM
C1064	ASM	NO_ASM
C1065	ASM	NO_ASM
C1066	ASM	NO_ASM
C1067	ASM	NO_ASM

**緯創資通 Wistron Corporation**  
 21F, 88, Sec.1, Hsin Tai Wu Rd., Hsichih,  
 Taipei Hsien 221, Taiwan, R.O.C.

Title: **GMCH (4/5) : Power**

Size: Document Number  
 Custm: Y Note-5  
 Date: Tuesday, December 28, 2004 Sheet 9 of 71

Rev: -2

U55F

ALVISO-GM-2  
38L5192AA

VSS267	AL24
VSS266	AN24
VSS265	E26
VSS264	G26
VSS263	J26
VSS262	B27
VSS261	E27
VSS129	G27
VSS128	W27
VSS126	AA27
VSS125	AB27
VSS124	AC27
VSS123	AD27
VSS122	AE27
VSS121	AF27
VSS120	AG27
VSS119	AN28
VSS118	E28
VSS117	W28
VSS116	AA28
VSS115	AB28
VSS114	AC28
VSS113	AD28
VSS112	E29
VSS111	G29
VSS110	H29
VSS109	L29
VSS107	P29
VSS106	V29
VSS105	W29
VSS103	Y29
VSS102	AA29
VSS101	AG29
VSS99	AM29
VSS98	C30
VSS97	AD30
VSS96	AA30
VSS95	AB30
VSS94	AC30
VSS93	AD30
VSS91	D31
VSS90	E31
VSS89	C31
VSS88	H31
VSS87	J31
VSS86	L31
VSS85	M31
VSS84	N31
VSS83	O31
VSS82	P31
VSS81	Q31
VSS80	R31
VSS79	T31
VSS78	U31
VSS77	W31
VSS76	W31
VSS75	AD31
VSS74	AG31
VSS73	AL31
VSS72	A32
VSS71	Y32
VSS70	AA32
VSS69	AB32
VSS68	AC32
VSS67	AD32
VSS66	AE32
VSS65	AF32
VSS64	AG32
VSS63	H33
VSS62	E33
VSS61	F33
VSS60	G33
VSS59	H33
VSS57	J33
VSS56	L33
VSS55	M33
VSS54	P33
VSS53	R33
VSS51	T33
VSS50	U33
VSS49	V33
VSS48	W33
VSS47	AD33
VSS46	AE33
VSS45	AF33
VSS44	AG33
VSS43	H34
VSS42	I34
VSS41	J34
VSS40	K34
VSS39	L34
VSS38	M34
VSS37	N34
VSS36	O34
VSS35	P34
VSS34	Q34
VSS33	R34
VSS32	T34
VSS31	U34
VSS30	V34
VSS29	W34
VSS28	W34
VSS27	AD34
VSS26	AE34
VSS25	AF34
VSS24	AG34
VSS23	H35
VSS22	I35
VSS21	J35
VSS20	K35
VSS19	L35
VSS18	M35
VSS17	N35
VSS16	O35
VSS15	P35
VSS14	Q35
VSS13	R35
VSS12	T35
VSS11	U35
VSS10	V35
VSS09	W35
VSS08	W35
VSS07	AD35
VSS06	AE35
VSS05	AF35
VSS04	AG35
VSS03	H36
VSS02	I36
VSS01	J36
VSS00	K36
VSS99	L36
VSS98	M36
VSS97	N36
VSS96	O36
VSS95	P36
VSS94	Q36
VSS93	R36
VSS92	T36
VSS91	U36
VSS90	V36
VSS89	W36
VSS88	W36
VSS87	AD36
VSS86	AE36
VSS85	AF36
VSS84	AG36
VSS83	H37
VSS82	I37
VSS81	J37
VSS80	K37
VSS79	L37
VSS78	M37
VSS77	N37
VSS76	O37
VSS75	P37
VSS74	Q37
VSS73	R37
VSS72	T37
VSS71	U37
VSS70	V37
VSS69	W37
VSS68	W37
VSS67	AD37
VSS66	AE37
VSS65	AF37
VSS64	AG37
VSS63	H38
VSS62	I38
VSS61	J38
VSS60	K38
VSS59	L38
VSS58	M38
VSS57	N38
VSS56	O38
VSS55	P38
VSS54	Q38
VSS53	R38
VSS52	T38
VSS51	U38
VSS50	V38
VSS49	W38
VSS48	W38
VSS47	AD38
VSS46	AE38
VSS45	AF38
VSS44	AG38
VSS43	H39
VSS42	I39
VSS41	J39
VSS40	K39
VSS39	L39
VSS38	M39
VSS37	N39
VSS36	O39
VSS35	P39
VSS34	Q39
VSS33	R39
VSS32	T39
VSS31	U39
VSS30	V39
VSS29	W39
VSS28	W39
VSS27	AD39
VSS26	AE39
VSS25	AF39
VSS24	AG39
VSS23	H40
VSS22	I40
VSS21	J40
VSS20	K40
VSS19	L40
VSS18	M40
VSS17	N40
VSS16	O40
VSS15	P40
VSS14	Q40
VSS13	R40
VSS12	T40
VSS11	U40
VSS10	V40
VSS09	W40
VSS08	W40
VSS07	AD40
VSS06	AE40
VSS05	AF40
VSS04	AG40
VSS03	H41
VSS02	I41
VSS01	J41
VSS00	K41
VSS99	L41
VSS98	M41
VSS97	N41
VSS96	O41
VSS95	P41
VSS94	Q41
VSS93	R41
VSS92	T41
VSS91	U41
VSS90	V41
VSS89	W41
VSS88	W41
VSS87	AD41
VSS86	AE41
VSS85	AF41
VSS84	AG41
VSS83	H42
VSS82	I42
VSS81	J42
VSS80	K42
VSS79	L42
VSS78	M42
VSS77	N42
VSS76	O42
VSS75	P42
VSS74	Q42
VSS73	R42
VSS72	T42
VSS71	U42
VSS70	V42
VSS69	W42
VSS68	W42
VSS67	AD42
VSS66	AE42
VSS65	AF42
VSS64	AG42
VSS63	H43
VSS62	I43
VSS61	J43
VSS60	K43
VSS59	L43
VSS58	M43
VSS57	N43
VSS56	O43
VSS55	P43
VSS54	Q43
VSS53	R43
VSS52	T43
VSS51	U43
VSS50	V43
VSS49	W43
VSS48	W43
VSS47	AD43
VSS46	AE43
VSS45	AF43
VSS44	AG43
VSS43	H44
VSS42	I44
VSS41	J44
VSS40	K44
VSS39	L44
VSS38	M44
VSS37	N44
VSS36	O44
VSS35	P44
VSS34	Q44
VSS33	R44
VSS32	T44
VSS31	U44
VSS30	V44
VSS29	W44
VSS28	W44
VSS27	AD44
VSS26	AE44
VSS25	AF44
VSS24	AG44
VSS23	H45
VSS22	I45
VSS21	J45
VSS20	K45
VSS19	L45
VSS18	M45
VSS17	N45
VSS16	O45
VSS15	P45
VSS14	Q45
VSS13	R45
VSS12	T45
VSS11	U45
VSS10	V45
VSS09	W45
VSS08	W45
VSS07	AD45
VSS06	AE45
VSS05	AF45
VSS04	AG45
VSS03	H46
VSS02	I46
VSS01	J46
VSS00	K46
VSS99	L46
VSS98	M46
VSS97	N46
VSS96	O46
VSS95	P46
VSS94	Q46
VSS93	R46
VSS92	T46
VSS91	U46
VSS90	V46
VSS89	W46
VSS88	W46
VSS87	AD46
VSS86	AE46
VSS85	AF46
VSS84	AG46
VSS83	H47
VSS82	I47
VSS81	J47
VSS80	K47
VSS79	L47
VSS78	M47
VSS77	N47
VSS76	O47
VSS75	P47
VSS74	Q47
VSS73	R47
VSS72	T47
VSS71	U47
VSS70	V47
VSS69	W47
VSS68	W47
VSS67	AD47
VSS66	AE47
VSS65	AF47
VSS64	AG47
VSS63	H48
VSS62	I48
VSS61	J48
VSS60	K48
VSS59	L48
VSS58	M48
VSS57	N48
VSS56	O48
VSS55	P48
VSS54	Q48
VSS53	R48
VSS52	T48
VSS51	U48
VSS50	V48
VSS49	W48
VSS48	W48
VSS47	AD48
VSS46	AE48
VSS45	AF48
VSS44	AG48
VSS43	H49
VSS42	I49
VSS41	J49
VSS40	K49
VSS39	L49
VSS38	M49
VSS37	N49
VSS36	O49
VSS35	P49
VSS34	Q49
VSS33	R49
VSS32	T49
VSS31	U49
VSS30	V49
VSS29	W49
VSS28	W49
VSS27	AD49
VSS26	AE49
VSS25	AF49
VSS24	AG49
VSS23	H50
VSS22	I50
VSS21	J50
VSS20	K50
VSS19	L50
VSS18	M50
VSS17	N50
VSS16	O50
VSS15	P50
VSS14	Q50
VSS13	R50
VSS12	T50
VSS11	U50
VSS10	V50
VSS09	W50
VSS08	W50
VSS07	AD50
VSS06	AE50
VSS05	AF50
VSS04	AG50
VSS03	H51
VSS02	I51
VSS01	J51
VSS00	K51
VSS99	L51
VSS98	M51
VSS97	N51
VSS96	O51
VSS95	P51
VSS94	Q51
VSS93	R51
VSS92	T51
VSS91	U51
VSS90	V51
VSS89	W51
VSS88	W51
VSS87	AD51
VSS86	AE51
VSS85	AF51
VSS84	AG51
VSS83	H52
VSS82	I52
VSS81	J52
VSS80	K52
VSS79	L52
VSS78	M52
VSS77	N52
VSS76	O52
VSS75	P52
VSS74	Q52
VSS73	R52
VSS72	T52
VSS71	U52
VSS70	V52
VSS69	W52
VSS68	W52
VSS67	AD52
VSS66	AE52
VSS65	AF52
VSS64	AG52
VSS63	H53
VSS62	I53
VSS61	J53
VSS60	K53
VSS59	L53
VSS58	M53
VSS57	N53
VSS56	O53
VSS55	P53
VSS54	Q53
VSS53	R53
VSS52	T53
VSS51	U53
VSS50	V53
VSS49	W53
VSS48	W53
VSS47	AD53
VSS46	AE53
VSS45	AF53
VSS44	AG53
VSS43	H54
VSS42	I54
VSS41	J54
VSS40	K54
VSS39	L54
VSS38	M54
VSS37	N54
VSS36	O54
VSS35	P54
VSS34	Q54
VSS33	R54
VSS32	T54
VSS31	U54
VSS30	V54
VSS29	W54
VSS28	W54
VSS27	AD54
VSS26	AE54
VSS25	AF54
VSS24	AG54
VSS23	H55
VSS22	I55
VSS21	J55
VSS20	K55
VSS19	L55
VSS18	M55
VSS17	N55
VSS16	O55
VSS15	P55
VSS14	Q55
VSS13	R55
VSS12	T55
VSS11	U55
VSS10	V55
VSS09	W55
VSS08	W55
VSS07	AD55
VSS06	AE55
VSS05	AF55
VSS04	AG55
VSS03	H56
VSS02	I56
VSS01	J56
VSS00	K56
VSS99	L56
VSS98	M56
VSS97	N56
VSS96	O56
VSS95	P56
VSS94	Q56
VSS93	R56
VSS92	T56
VSS91	U56
VSS90	V56
VSS89	W56
VSS88	W56
VSS87	AD56
VSS86	AE56
VSS85	AF56
VSS84	AG56
VSS83	H57
VSS82	I57
VSS81	J57
VSS80	K57
VSS79	L57
VSS78	M57
VSS77	N57
VSS76	O57
VSS75	P57
VSS74	Q57
VSS73	R57
VSS72	T57
VSS71	U57
VSS70	V57
VSS69	W57
VSS68	W57
VSS67	AD57
VSS66	AE57
VSS65	AF57
VSS64	AG57
VSS63	H58
VSS62	I58
VSS61	J58
VSS60	K58
VSS59	L58
VSS58	M58
VSS57	N58
VSS56	O58
VSS55	P58
VSS54	Q58
VSS53	R58
VSS52	T58
VSS51	U58
VSS50	V58
VSS49	W58
VSS48	W58
VSS47	AD58
VSS46	AE58
VSS45	AF58
VSS44	AG58
VSS43	H59
VSS42	I59
VSS41	J59
VSS40	K59
VSS39	L59
VSS38	M59
VSS37	N59
VSS36	O59
VSS35	P59
VSS34	Q59
VSS33	R59
VSS32	T59
VSS31	U59
V	

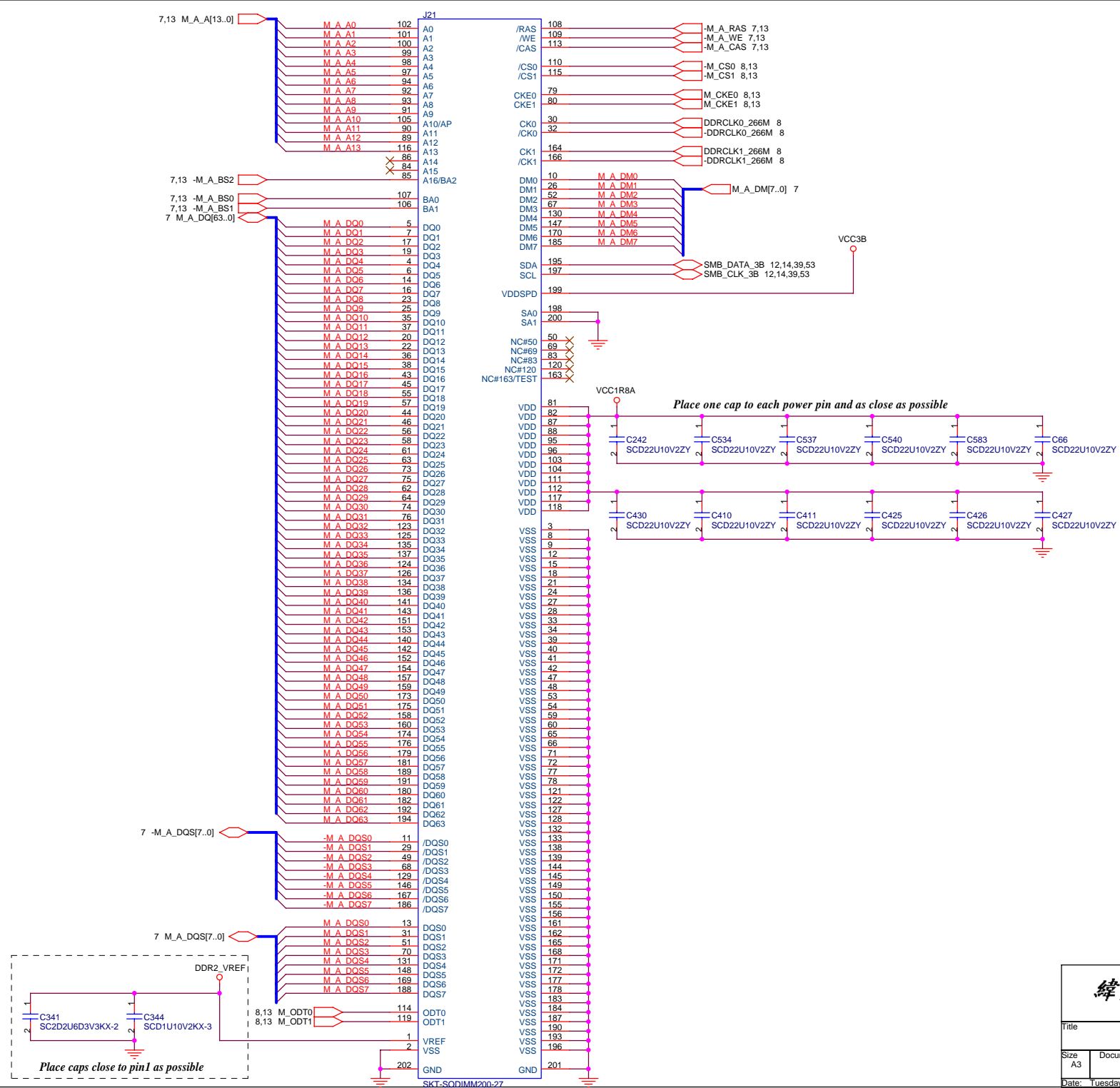

<b>緯創資通 Wistron Corporation</b>	
21F, 88, Sec.1, Hsin Tai Wu Rd., Hsichih, Taipei Hsien 221, Taiwan, R.O.C.	
Title <b>DDR-2 SO-DIMM A</b>	
Size A3	Document Number <b>Y Note-5</b>
Date: Tuesday, December 28, 2004	Sheet 11 of 71

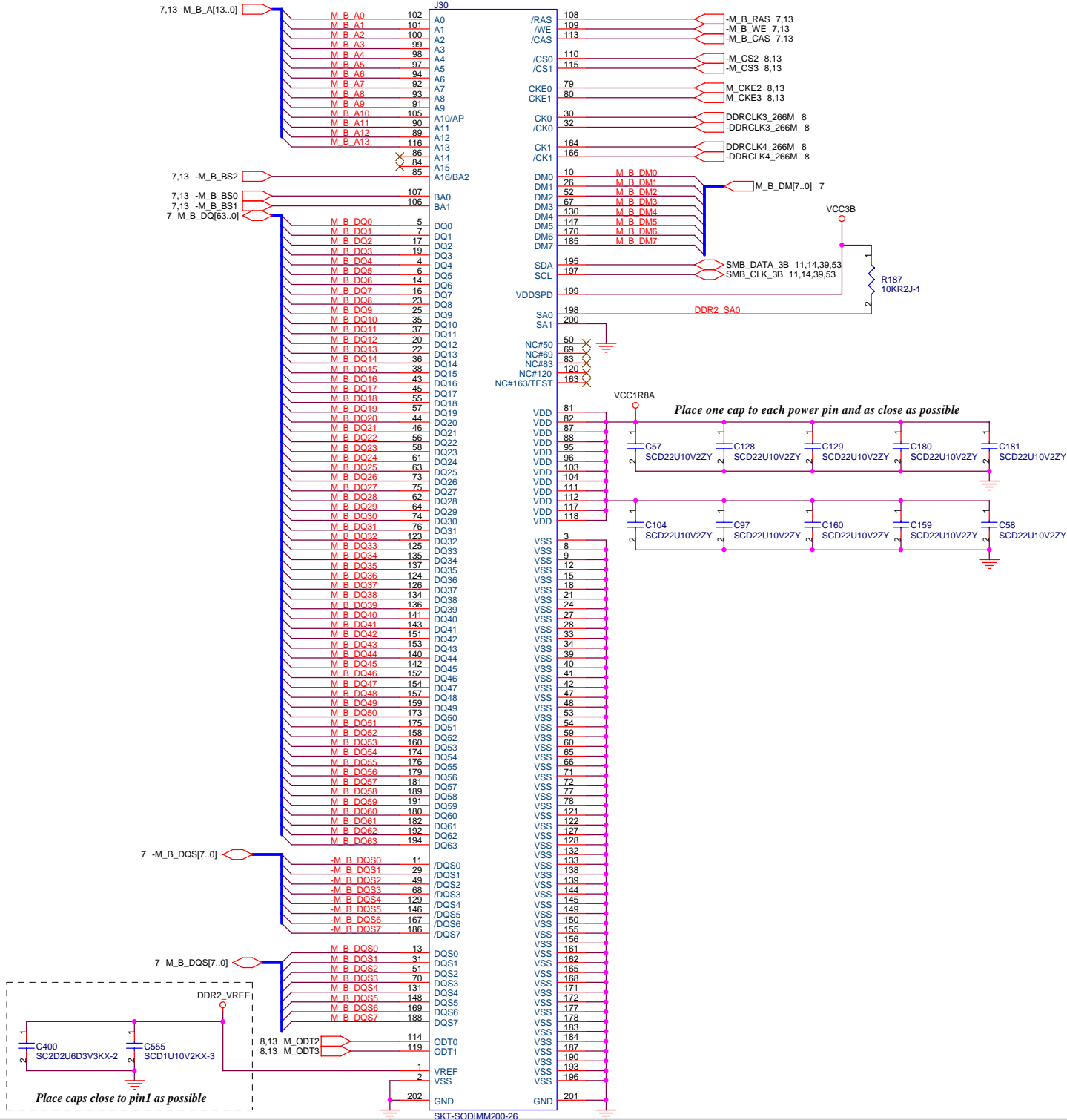

<b>緯創資通</b>		<b>Wistron Corporation</b>	
21F, 88, Sec.1, Hsin Tai Wu Rd., Hsichih, Taipei Hsien 221, Taiwan, R.O.C.			
Title			
<b>DDR-2 SO-DIMM B</b>			
Size	Document Number	Rev	
A3	<b>Y Note-5</b>	-2	
Date:	Tuesday, December 28, 2004	Sheet	12 of 71

# PARALLEL TERMINATION

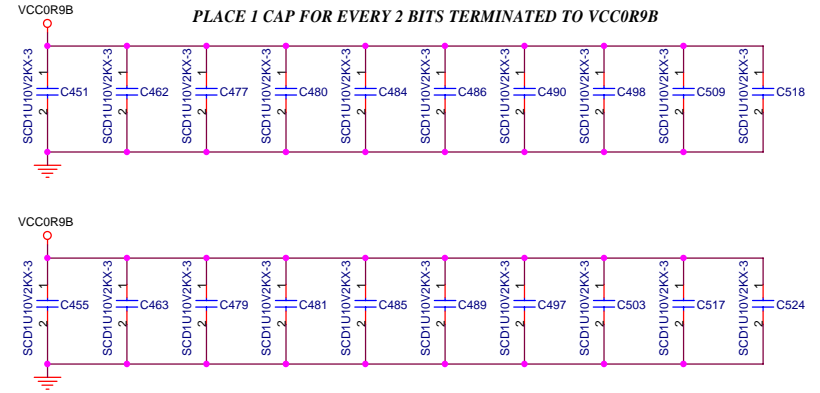
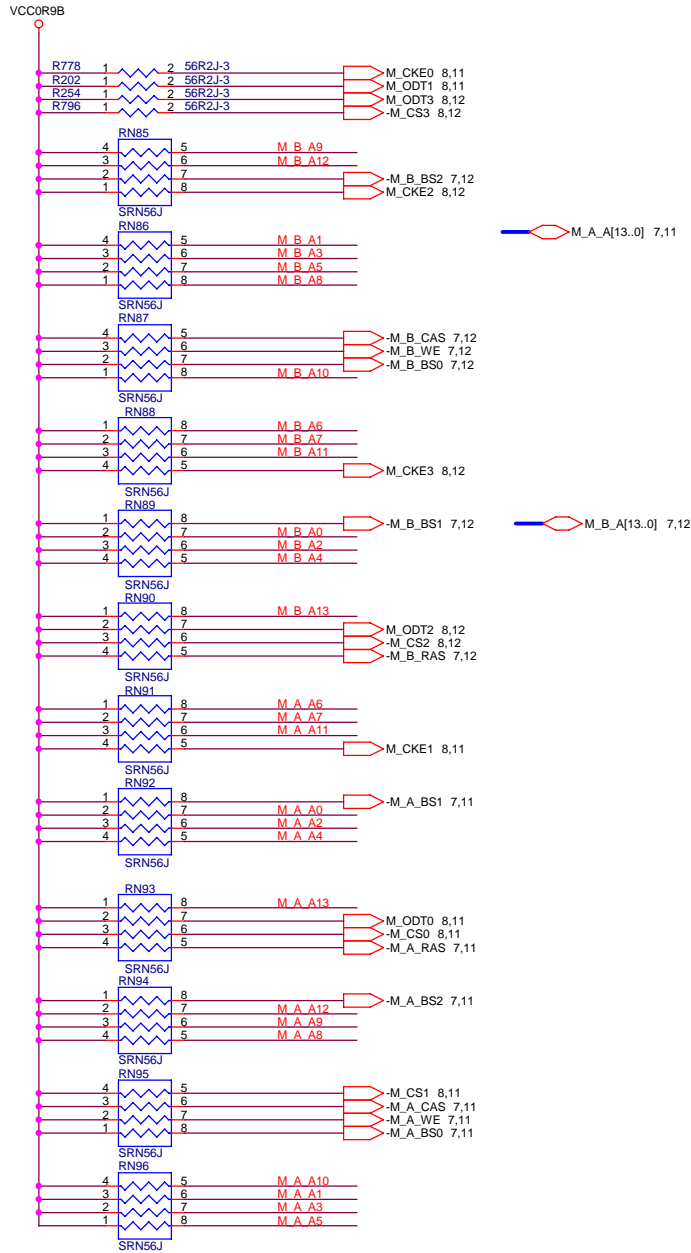

緯創資通 Wistron Corporation  
 21F, 88, Sec.1, Hsin Tai Wu Rd., Hsichih,  
 Taipei Hsien 221, Taiwan, R.O.C.

Title		
DDR-2 TERMINATION		
Size	Document Number	Rev
A3	Y Note-5	-1
Date:	Tuesday, December 28, 2004	Sheet 13 of 71

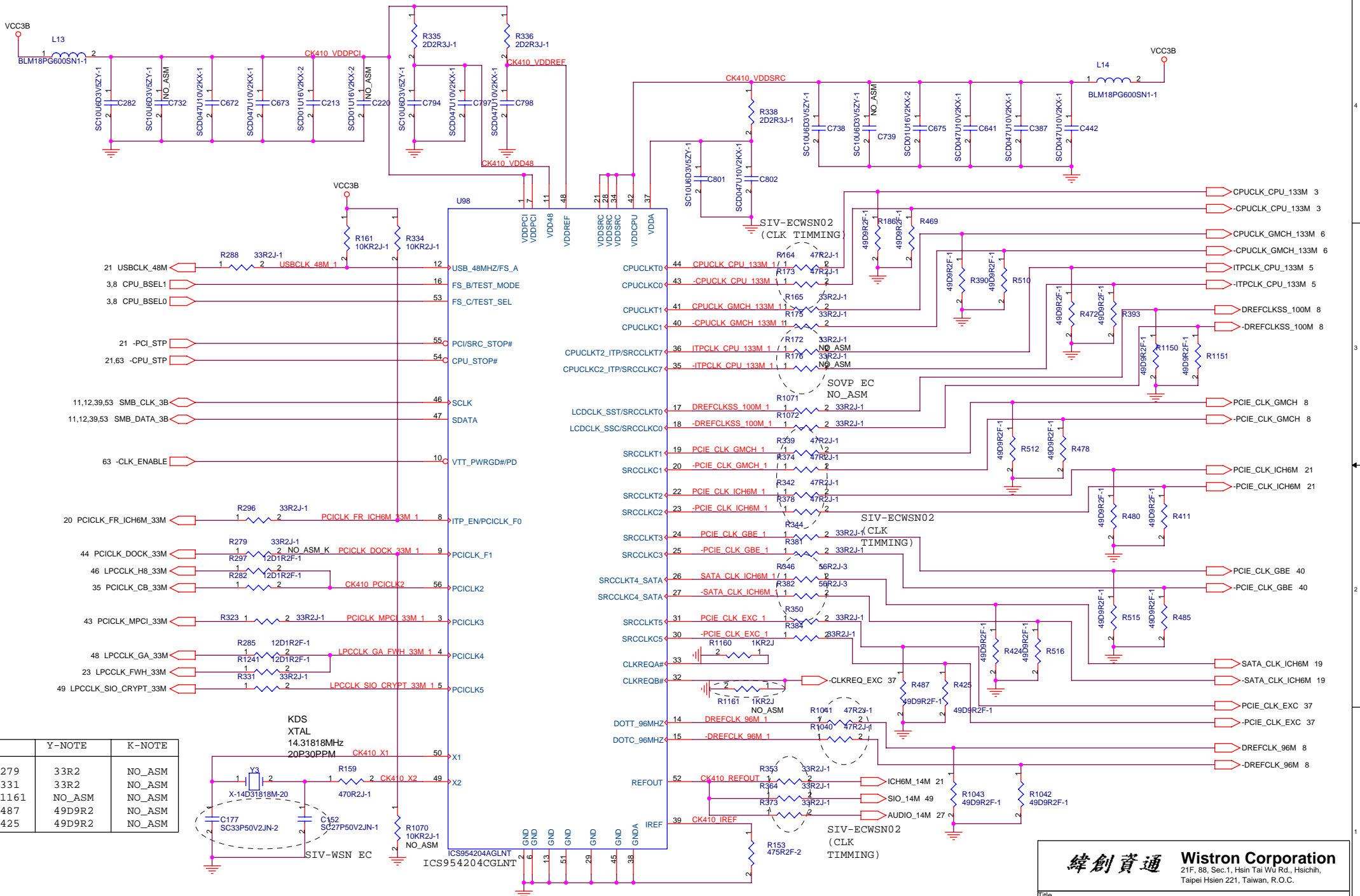

	Y-NOTE	K-NOTE
R279	33R2	NO_ASM
R331	33R2	NO_ASM
R1161	NO_ASM	NO_ASM
R487	49D9R2	NO_ASM
R425	49D9R2	NO_ASM

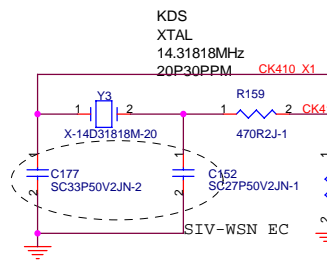

**緯創資通 Wistron Corporation**  
21F, 88, Sec. 1, Hsin Tai Wu Rd., Hsichih,  
Taipei Hsien 221, Taiwan, R.O.C.

---

Title: **CLOCK GENERATOR**

Size: A3	Document Number: <b>Y Note-5</b>	Rev: -2
Date: Wednesday, December 29, 2004		Sheet: 14 of 71

	Y-NOTE	K-NOTE
C926	NO_ASM	NO_ASM
C927	NO_ASM	NO_ASM
C928	NO_ASM	NO_ASM
C929	NO_ASM	NO_ASM
R668	NO_ASM	NO_ASM
R410	NO_ASM	NO_ASM

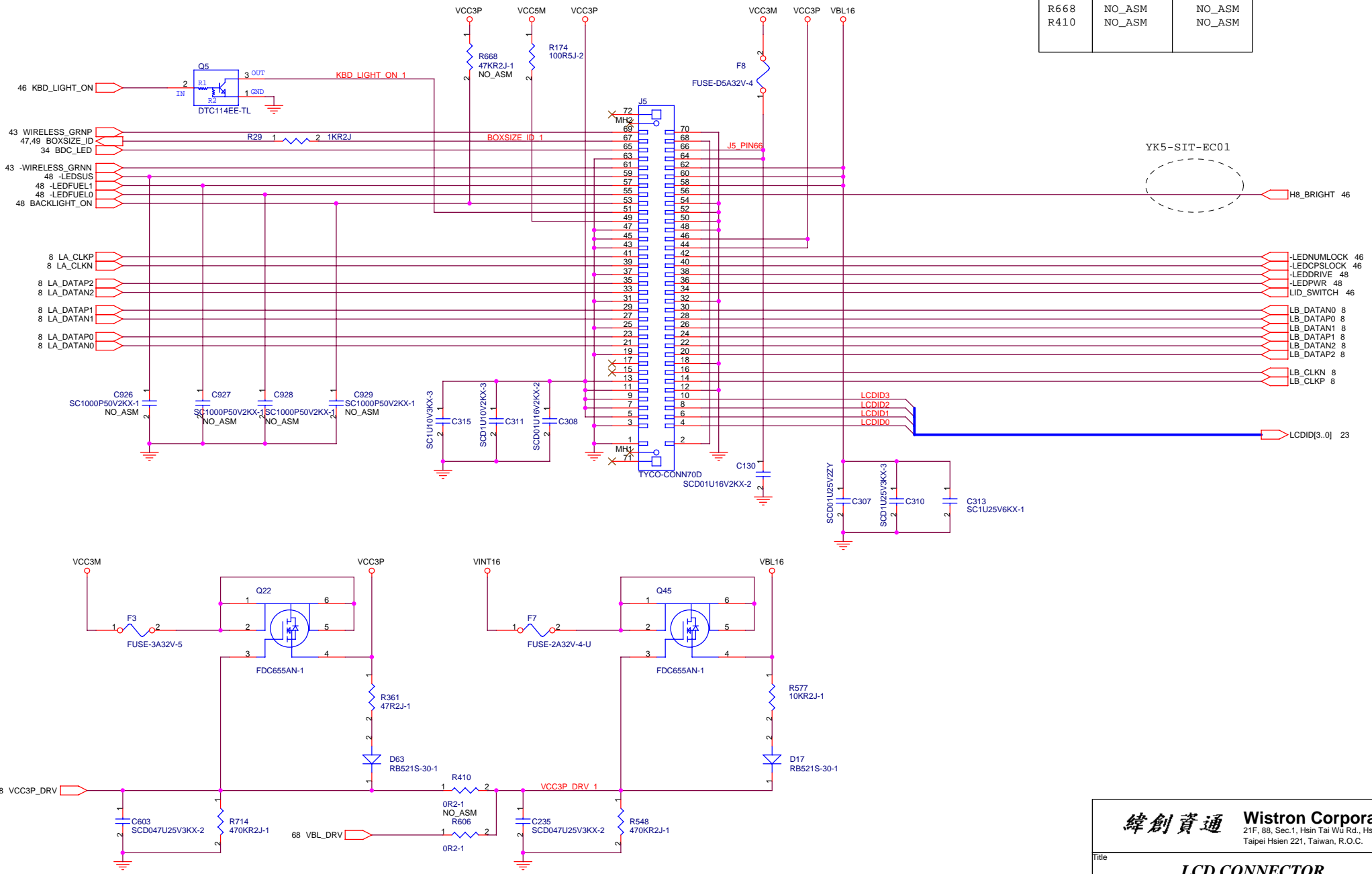

**緯創資通 Wistron Corporation**  
 21F, 88, Sec.1, Hsin Tai Wj Rd., Hsichih,  
 Taipei Hsien 221, Taiwan, R.O.C.

Title <b>LCD CONNECTOR</b>		
Size A3	Document Number <b>Y Note-5</b>	Rev -2
Date: Tuesday, December 28, 2004 Sheet 15 of 71		

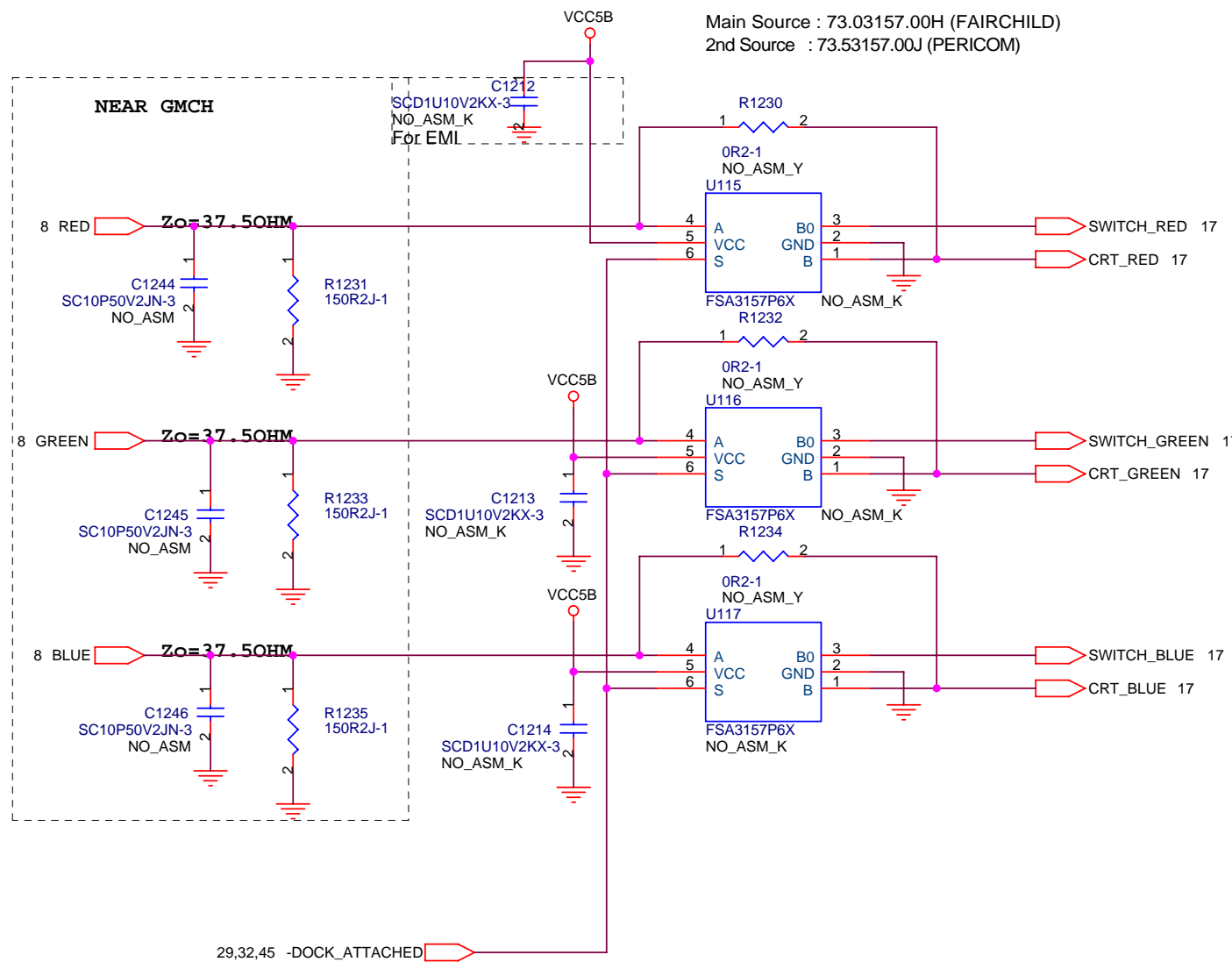

	Y-NOTE	K-NOTE
R1230	NO_ASM	0R2
R1232	NO_ASM	0R2
R1234	NO_ASM	0R2
U115	ASM	NO_ASM
U116	ASM	NO_ASM
U117	ASM	NO_ASM
C1212	ASM	NO_ASM
C1213	ASM	NO_ASM
C1214	ASM	NO_ASM

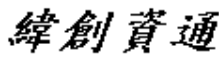
**Wistron Corporation**  
 21F, 88, Sec.1, Hsin Tai Wu Rd., Hsichih,  
 Taipei Hsien 221, Taiwan, R.O.C.

---

Title: **CRT SWITCH**

Size: A4	Document Number: <b>Y Note-5</b>	Rev: -2
----------	----------------------------------	---------

Date: Tuesday, December 28, 2004      Sheet 16 of 71



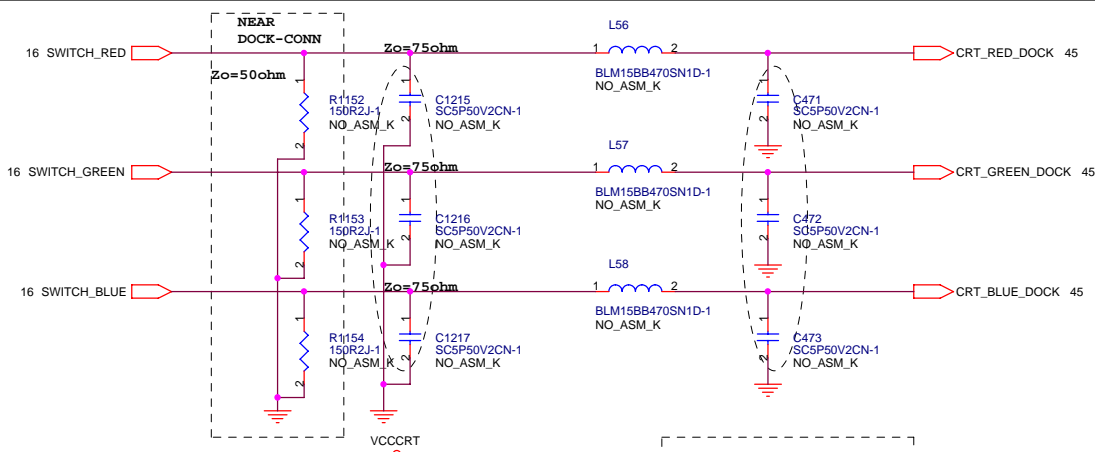

	Y-NOTE	K-NOTE
C787	NO_ASM	NO_ASM
C788	NO_ASM	NO_ASM
C727	NO_ASM	NO_ASM
C730	NO_ASM	NO_ASM
R348	NO_ASM	NO_ASM
R349	NO_ASM	NO_ASM
C471	ASM	NO_ASM
C472	ASM	NO_ASM
C473	ASM	NO_ASM
L56	ASM	NO_ASM
L57	ASM	NO_ASM
L58	ASM	NO_ASM
R1152	ASM	NO_ASM
R1153	ASM	NO_ASM
R1154	ASM	NO_ASM
C1215	ASM	NO_ASM
C1216	ASM	NO_ASM
C1217	ASM	NO_ASM

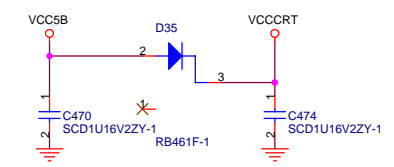
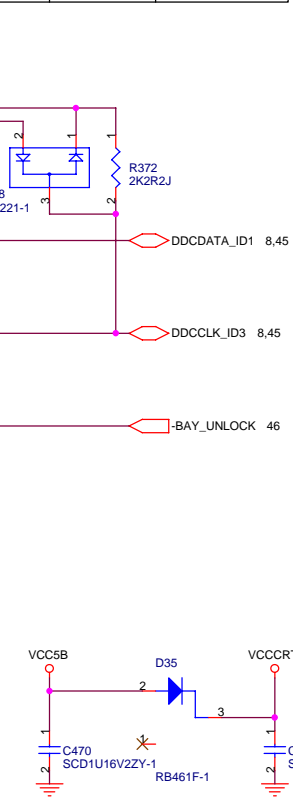
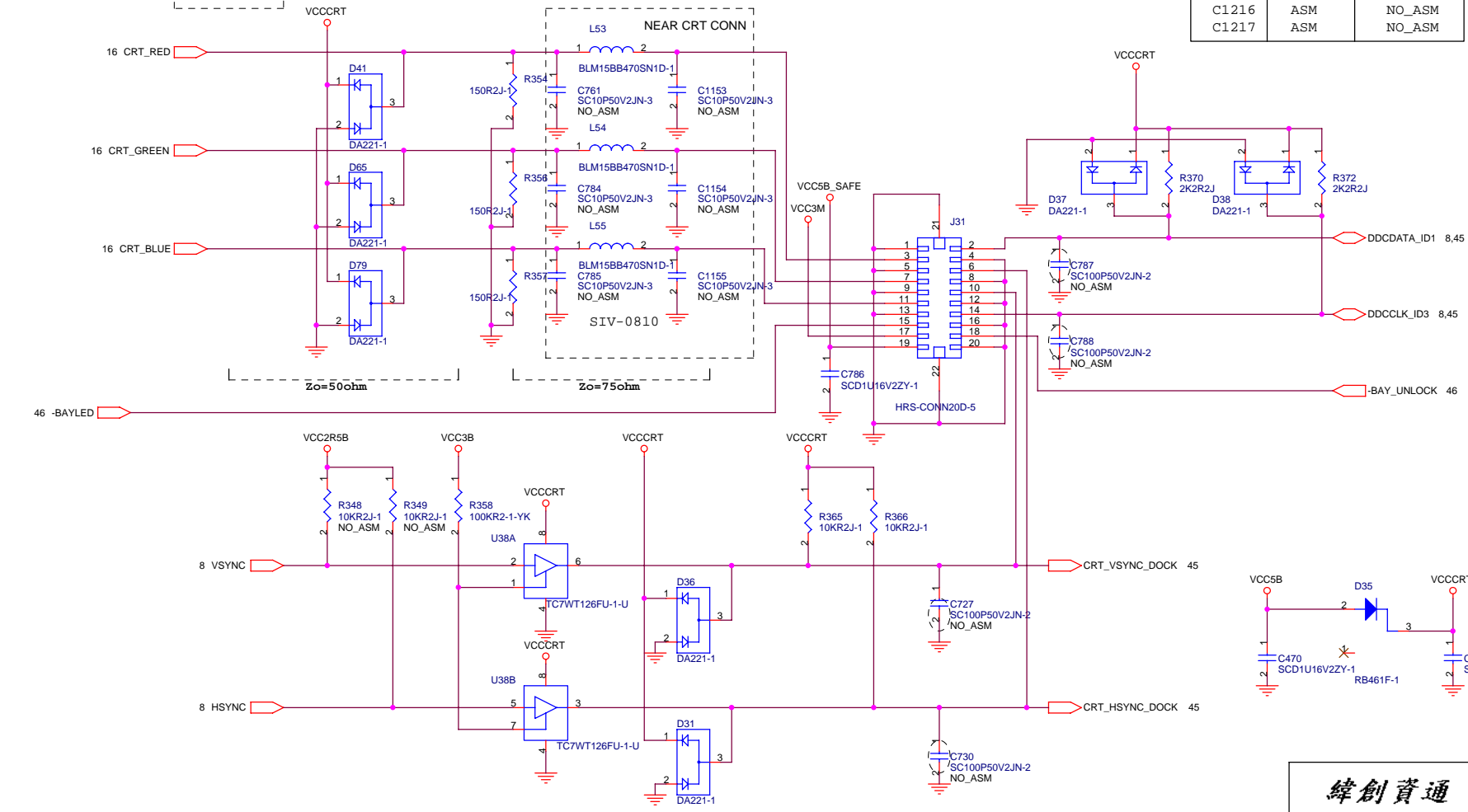

**緯創資通 Wistron Corporation**  
21F, 88, Sec.1, Hsin Tai Wu Rd., Hsichih, Taipei Hsien 221, Taiwan, R.O.C.

Title: **CRT I/F**

Size: A3 Document Number: **Y Note-5** Rev: -2

Date: Tuesday, December 28, 2004 Sheet 17 of 71

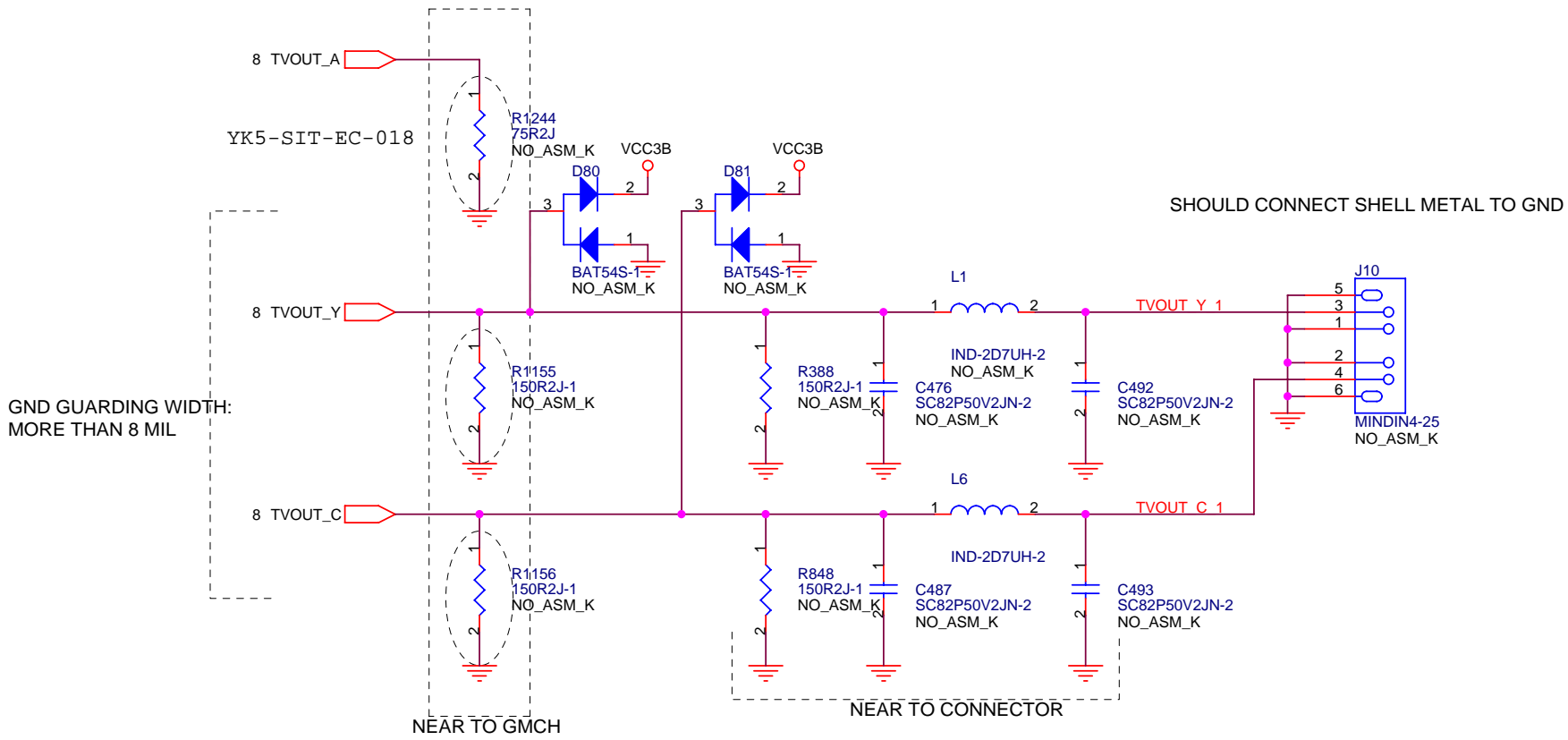

	Y-NOTE	K-NOTE
R1155	150-OHM	NO_ASM
R1156	150-OHM	NO_ASM
R1244	75-OHM	NO_ASM
C492	ASM	NO_ASM
C493	ASM	NO_ASM
C476	ASM	NO_ASM
C487	ASM	NO_ASM
L1	ASM	NO_ASM
L6	ASM	NO_ASM
R388	ASM	NO_ASM
R848	ASM	NO_ASM
D80	ASM	NO_ASM
D81	ASM	NO_ASM
J10	ASM	NO_ASM

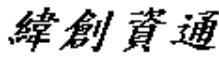
**Wistron Corporation**  
 21F, 88, Sec.1, Hsin Tai Wu Rd., Hsichih,  
 Taipei Hsien 221, Taiwan, R.O.C.

---

Title **TV OUT**

---

Size A4	Document Number <b>Y Note-5</b>	Rev -2
------------	------------------------------------	-----------

---

Date: Tuesday, December 28, 2004      Sheet 18 of 71

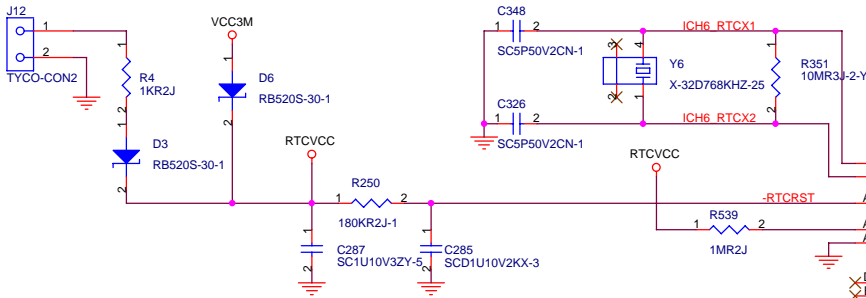

	Y-note	K-note
R535	NO_ASM	NO_ASM
R19	NO_ASM	NO_ASM
R23	NO_ASM	NO_ASM
R38	NO_ASM	NO_ASM
R218	NO_ASM	NO_ASM

If -AC97\_RST\_R is confirmed static in SDV phase. Please remove R456 Dumper and connect directly to A10 (ACZ\_RST#)

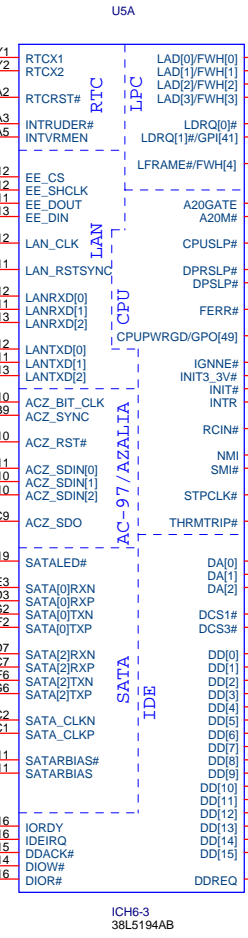
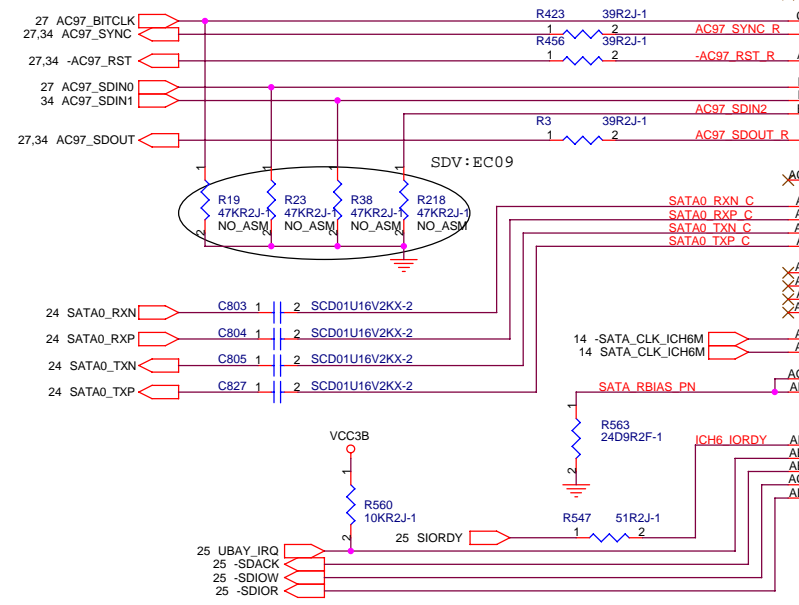

ICH6-3  
38L5194AB  
38L5194AA FW82801FBM, SL\_\_\_ Rev:C-0  
38L5194AB (#RM4106) ICH6 rev.B2  
source package:#RM4011

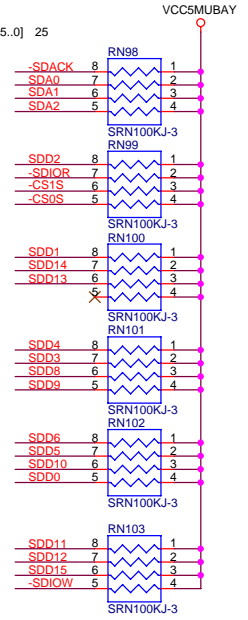
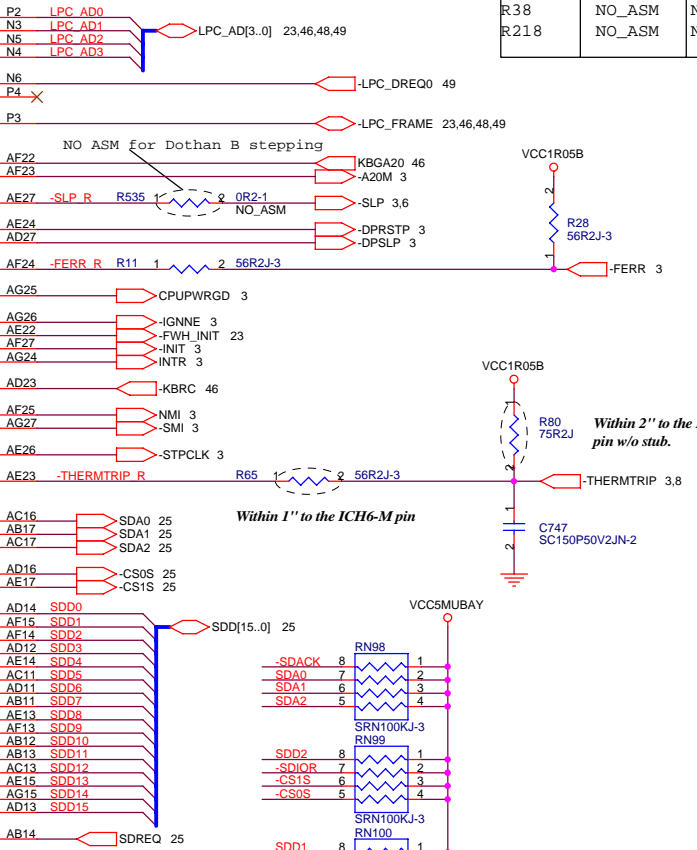

**緯創資通 Wistron Corporation**  
21F, 88, Sec.1, Hsin Tai Wu Rd., Hsichih,  
Taipei Hsien 221, Taiwan, R.O.C.

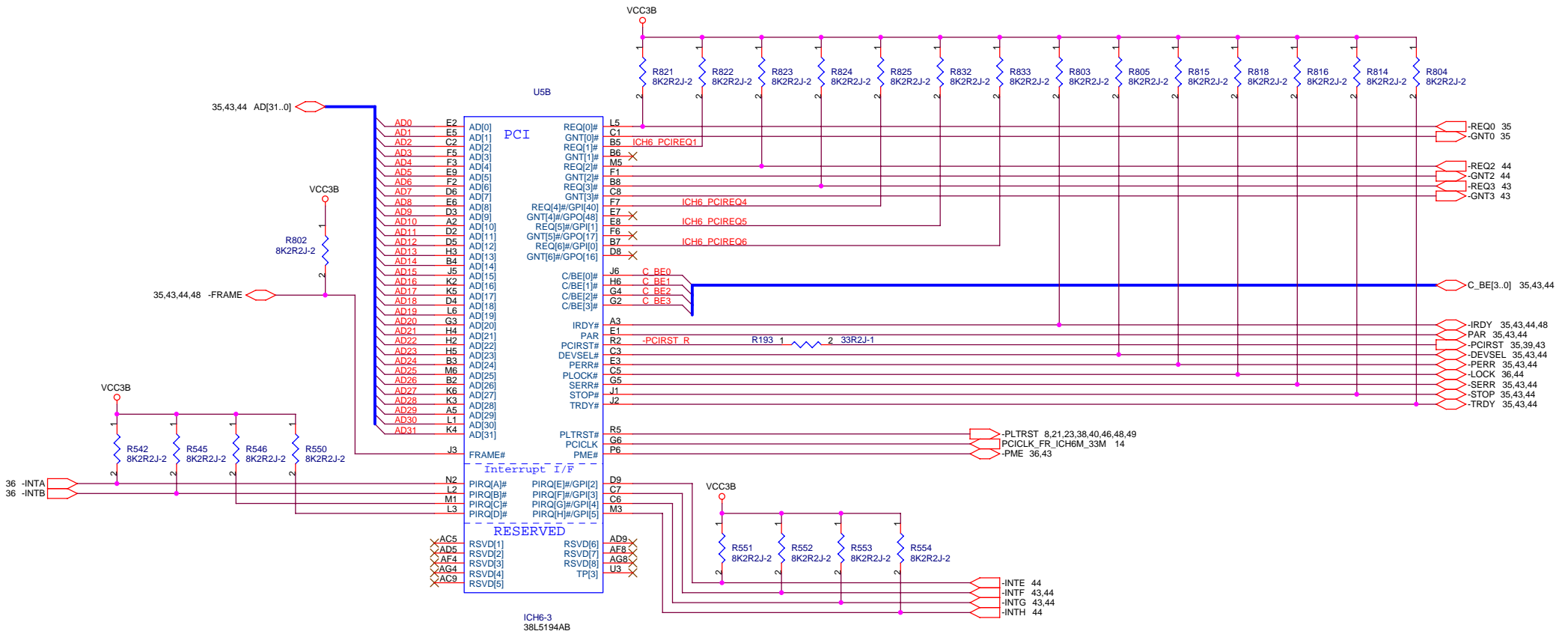

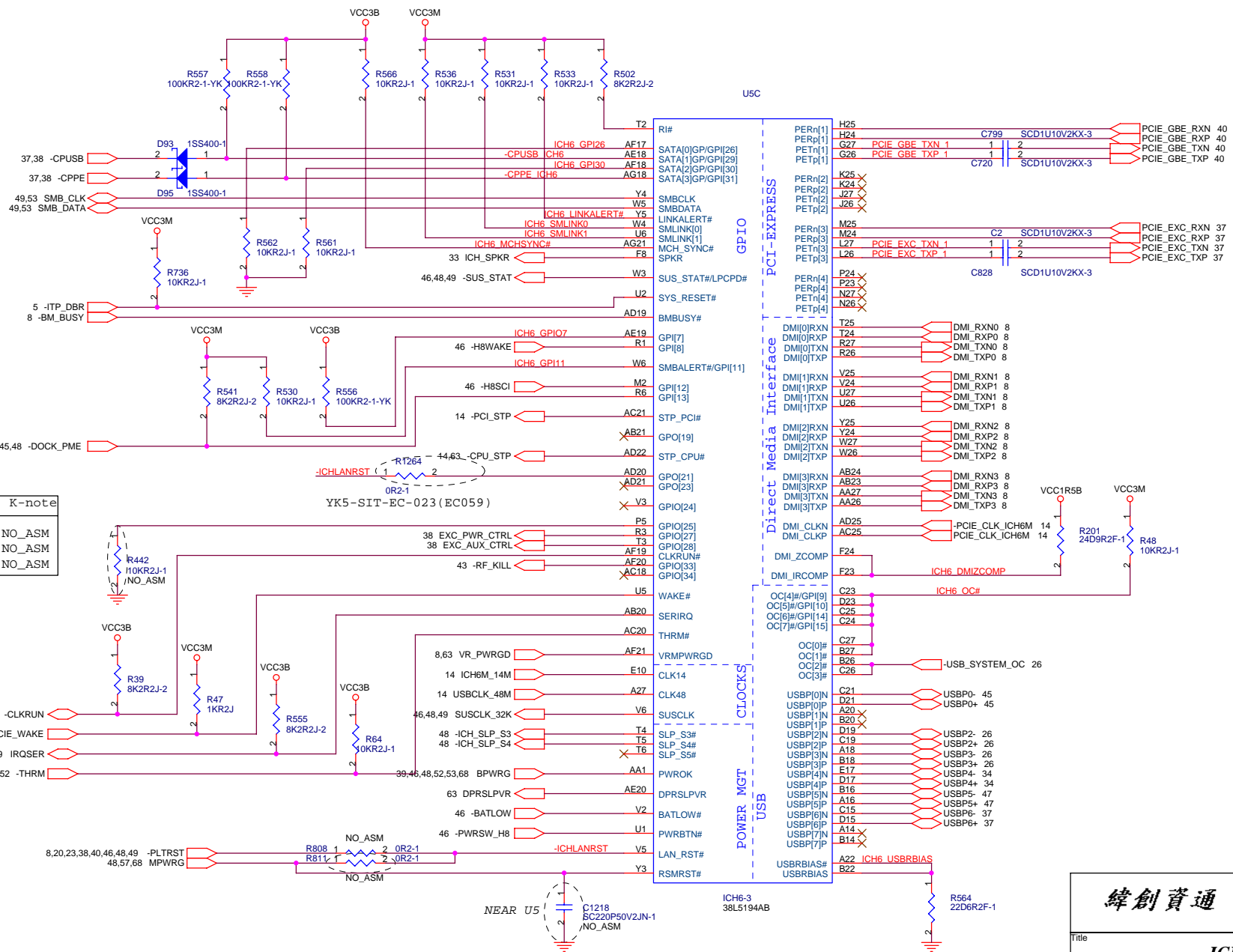

	Y-note	K-note
R442	NO_ASM	NO_ASM
R811	NO_ASM	NO_ASM
C1218	NO_ASM	NO_ASM

**緯創資通 Wistron Corporation**  
 21F, 88, Sec.1, Hsin Tai Wu Rd., Hsichih,  
 Taipei Hsien 221, Taiwan, R.O.C.

---

Title: **ICH6-M (3/4)**

Size: A3 Document Number: **Y Note-5** Rev: -2

Date: Tuesday, December 28, 2004 Sheet 21 of 71

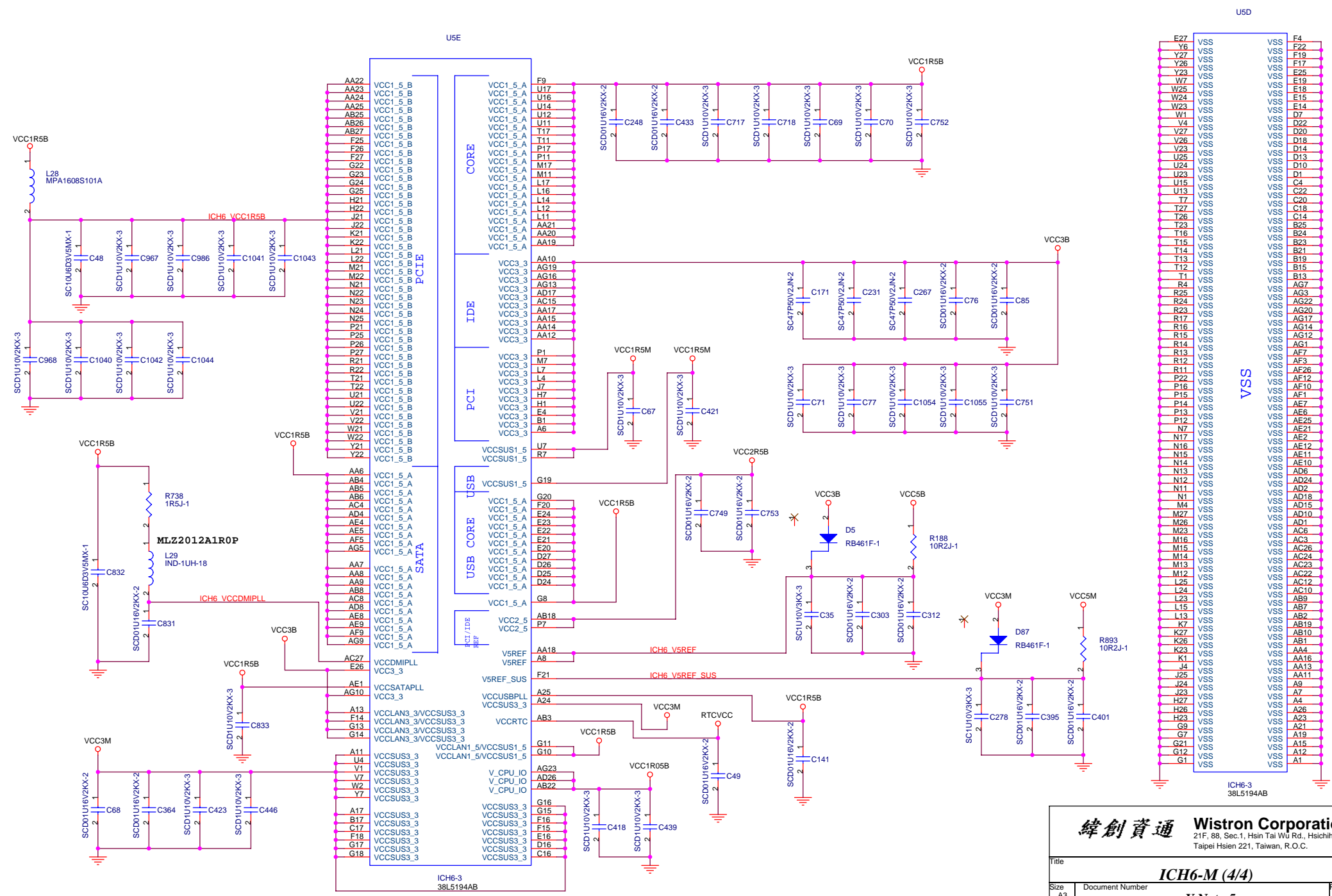

**緯創資通 Wistron Corporation**  
 21F, 88, Sec.1, Hsin Tai Wu Rd., Hsichih,  
 Taipei Hsien 221, Taiwan, R.O.C.

---

Title: **ICH6-M (4/4)**

Size A3 Document Number **Y Note-5** Rev -2

Date: Tuesday, December 28, 2004 Sheet 22 of 71

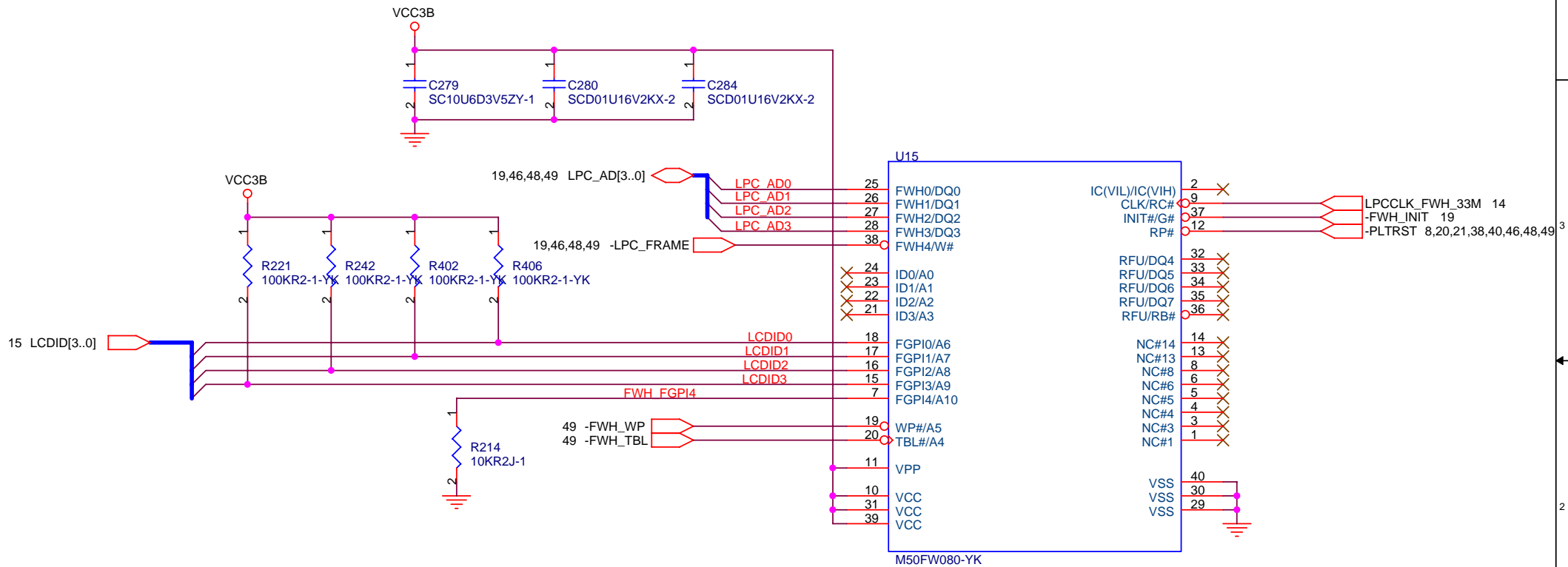

STMicro M50FW080K1 : 38L4888BA  
 SST 49LF008 : 38L4888AA  
 Atmel : 38L4888CB

<b>緯創資通</b>		<b>Wistron Corporation</b>	
		21F, 88, Sec.1, Hsin Tai Wu Rd., Hsichih, Taipei Hsien 221, Taiwan, R.O.C.	
<b>Title</b>			
<b>FWH</b>			
Size A4	Document Number		Rev -2
		<b>Y Note-5</b>	
Date:	Tuesday, December 28, 2004	Sheet 23 of	71

	88SA8040	SIL3811
U31	88SA8040	SIL3811
R569	ASM	NO_ASM
R572	ASM	NO_ASM
R880	NO_ASM	ASM
R882	NO_ASM	ASM
R884	NO_ASM	ASM
FL7	NO_ASM	ASM
FL12	ASM	NO_ASM
R578	ASM	NO_ASM
R878	ASM	NO_ASM
R883	ASM	NO_ASM
R879	ASM	NO_ASM
R573	680R2	0R2
R428	NO_ASM	ASM
R584	12.1K	1K
C482	NO_ASM	ASM
R352	NO_ASM	ASM

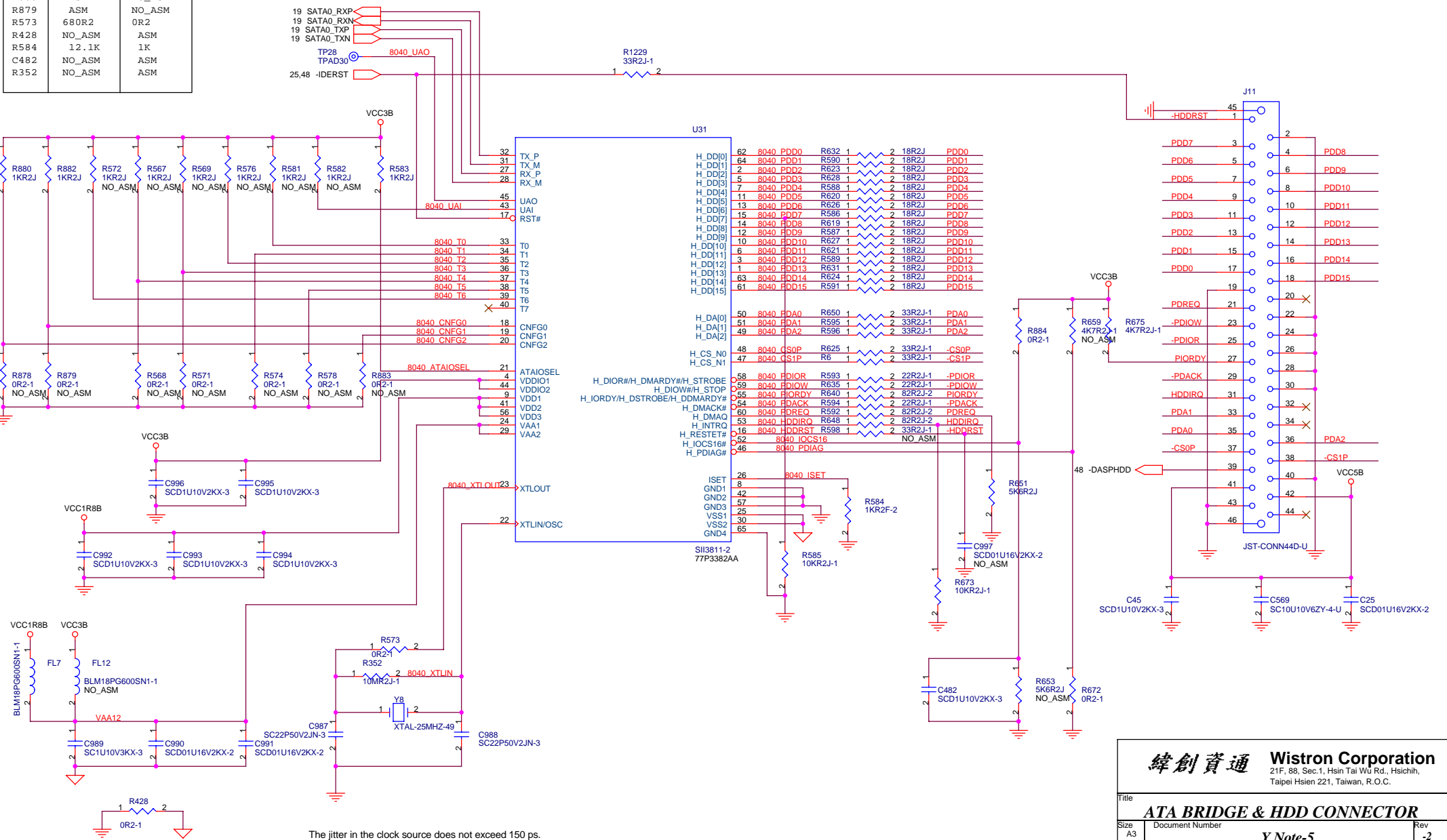

The jitter in the clock source does not exceed 150 ps.

**緯創資通 Wistron Corporation**  
21F, 88, Sec.1, Hsin Tai Wu Rd., Hsichih, Taipei Hsien 221, Taiwan, R.O.C.

Title <b>ATA BRIDGE &amp; HDD CONNECTOR</b>		
Size A3	Document Number <b>Y Note-5</b>	Rev -2
Date Tuesday, December 28, 2004	Sheet 24	of 71



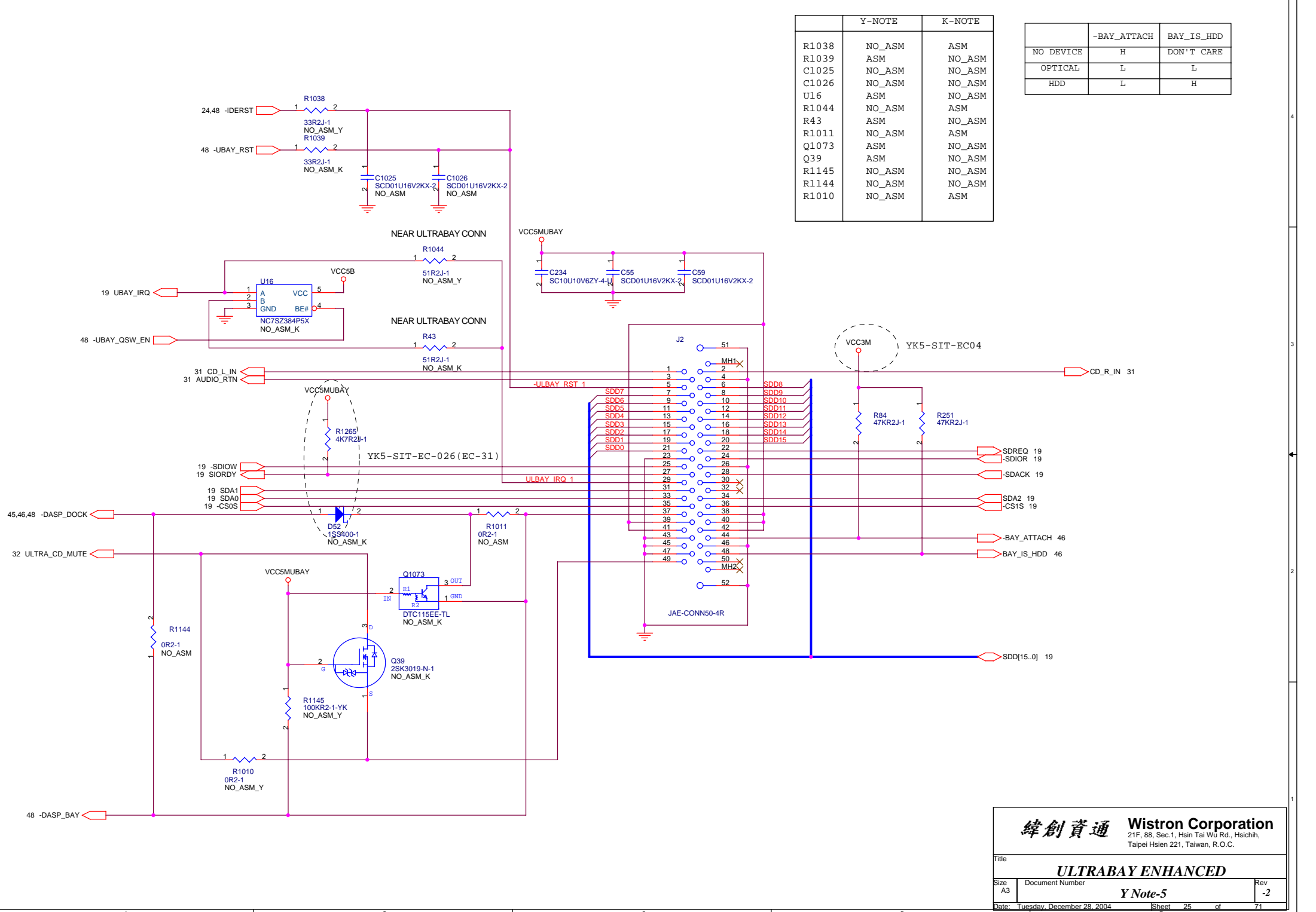

	Y-NOTE	K-NOTE
R1038	NO_ASM	ASM
R1039	ASM	NO_ASM
C1025	NO_ASM	NO_ASM
C1026	NO_ASM	NO_ASM
U16	ASM	NO_ASM
R1044	NO_ASM	ASM
R43	ASM	NO_ASM
R1011	NO_ASM	ASM
Q1073	ASM	NO_ASM
Q39	ASM	NO_ASM
R1145	NO_ASM	NO_ASM
R1144	NO_ASM	NO_ASM
R1010	NO_ASM	ASM

	-BAY_ATTACH	BAY_IS_HDD
NO_DEVICE	H	DON'T CARE
OPTICAL	L	L
HDD	L	H

**緯創資通** **Wistron Corporation**  
 21F, 88, Sec.1, Hsin Tai Wj Rd., Hsichih,  
 Taipei Hsien 221, Taiwan, R.O.C.

Title		
<b>ULTRABAY ENHANCED</b>		
Size	Document Number	Rev
A3		<b>Y Note-5</b> -2
Date: Tuesday, December 28, 2004		
Sheet 25 of 71		

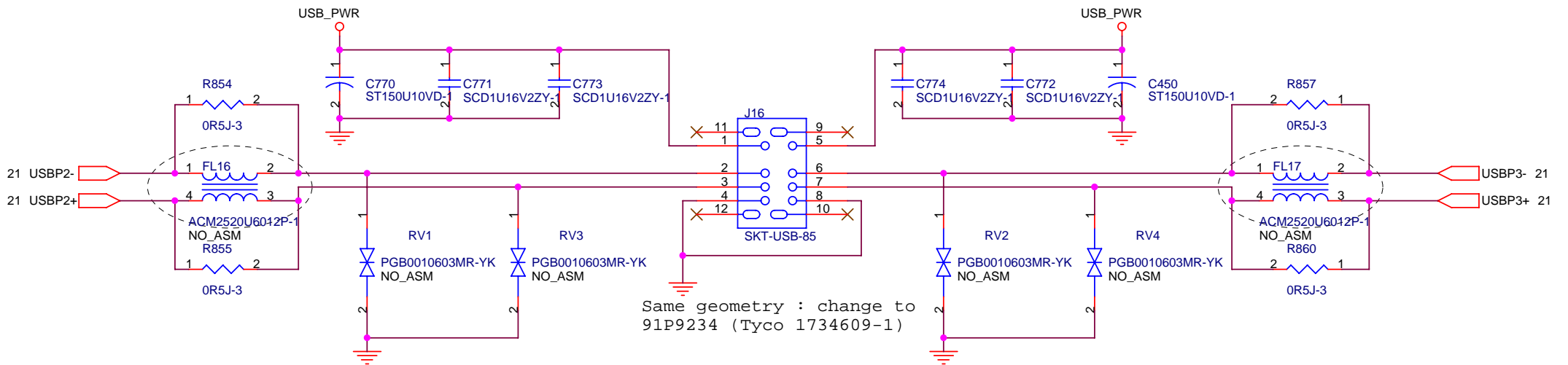
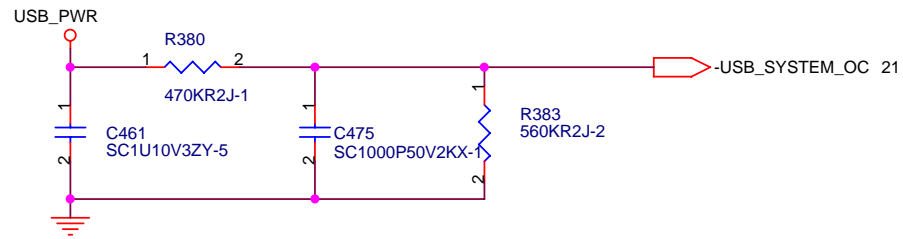

Same geometry : change to 91P9234 (Tyco 1734609-1)

	Y-NOTE	K-NOTE
FL16	NO_ASM	NO_ASM
RV1	NO_ASM	NO_ASM
RV3	NO_ASM	NO_ASM
RV2	NO_ASM	NO_ASM
RV4	NO_ASM	NO_ASM
FL17	NO_ASM	NO_ASM

**Wistron Corporation**  
 21F, 88, Sec.1, Hsin Tai Wu Rd., Hsichih,  
 Taipei Hsien 221, Taiwan, R.O.C.

---

Title: **USB CONNECTOR**

Size A4	Document Number <b>Y Note-5</b>	Rev -2
------------	------------------------------------	-----------

Date: Tuesday, December 28, 2004      Sheet 26 of 71

	Y-NOTE	K-NOTE
C329	NO_ASM	NO_ASM
C34	NO_ASM	NO_ASM
C28	NO_ASM	NO_ASM
C14	NO_ASM	NO_ASM
C114	NO_ASM	NO_ASM
C106	NO_ASM	NO_ASM
C980	NO_ASM	NO_ASM
C62	NO_ASM	NO_ASM
C318	NO_ASM	NO_ASM
C43	NO_ASM	NO_ASM

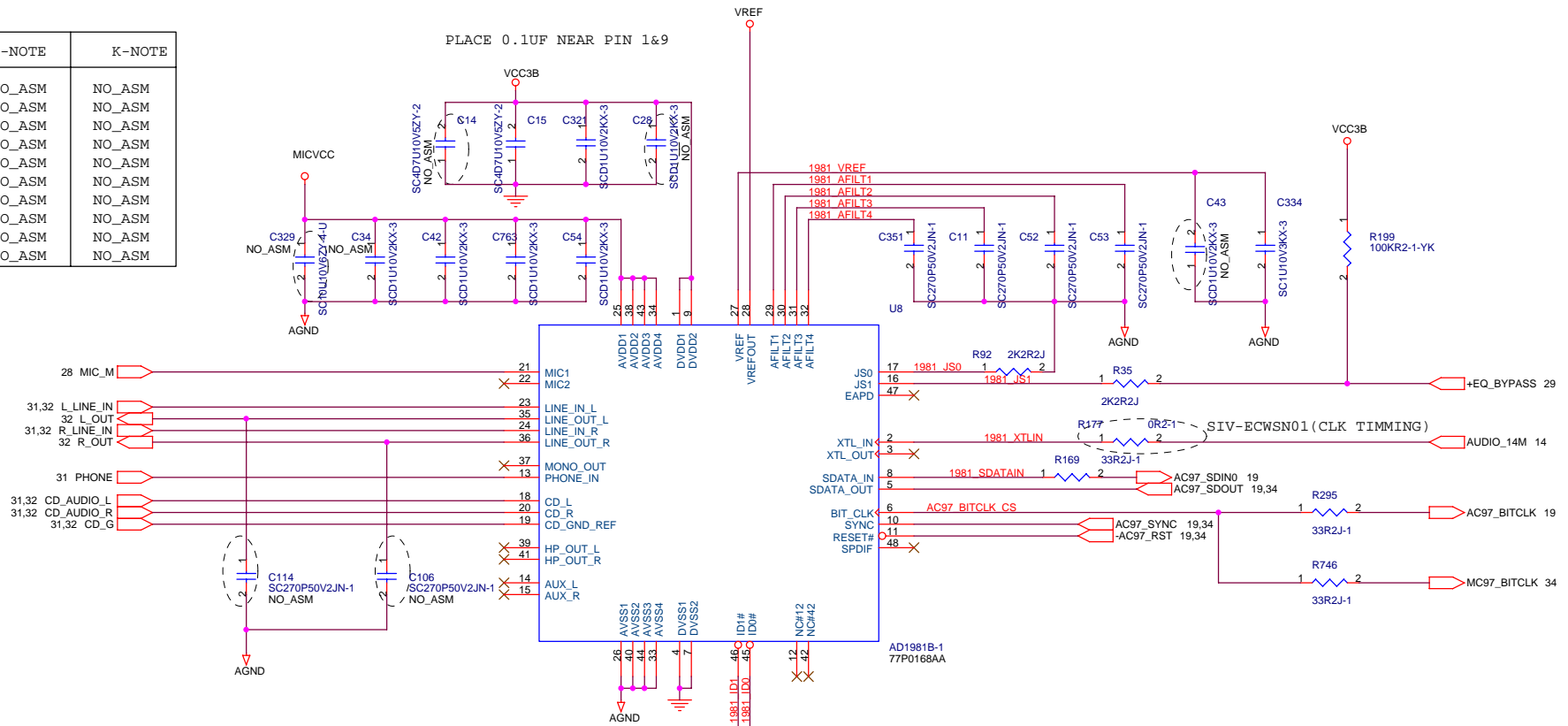

PLACE UNDER AD1981A

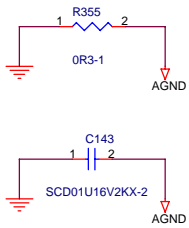

## VCC5MA

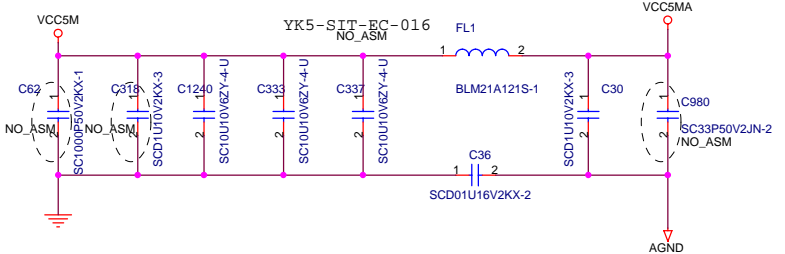

**緯創資通 Wistron Corporation**  
21F, 88, Sec.1, Hsin Tai WJ Rd., Hsichih,  
Taipei Hsien 221, Taiwan, R.O.C.

Title: **AUDIO AD1981B**

Size: A3 | Document Number: **Y Note-5** | Rev: -2

Date: Tuesday, December 28, 2004 | Sheet: 27 of 71

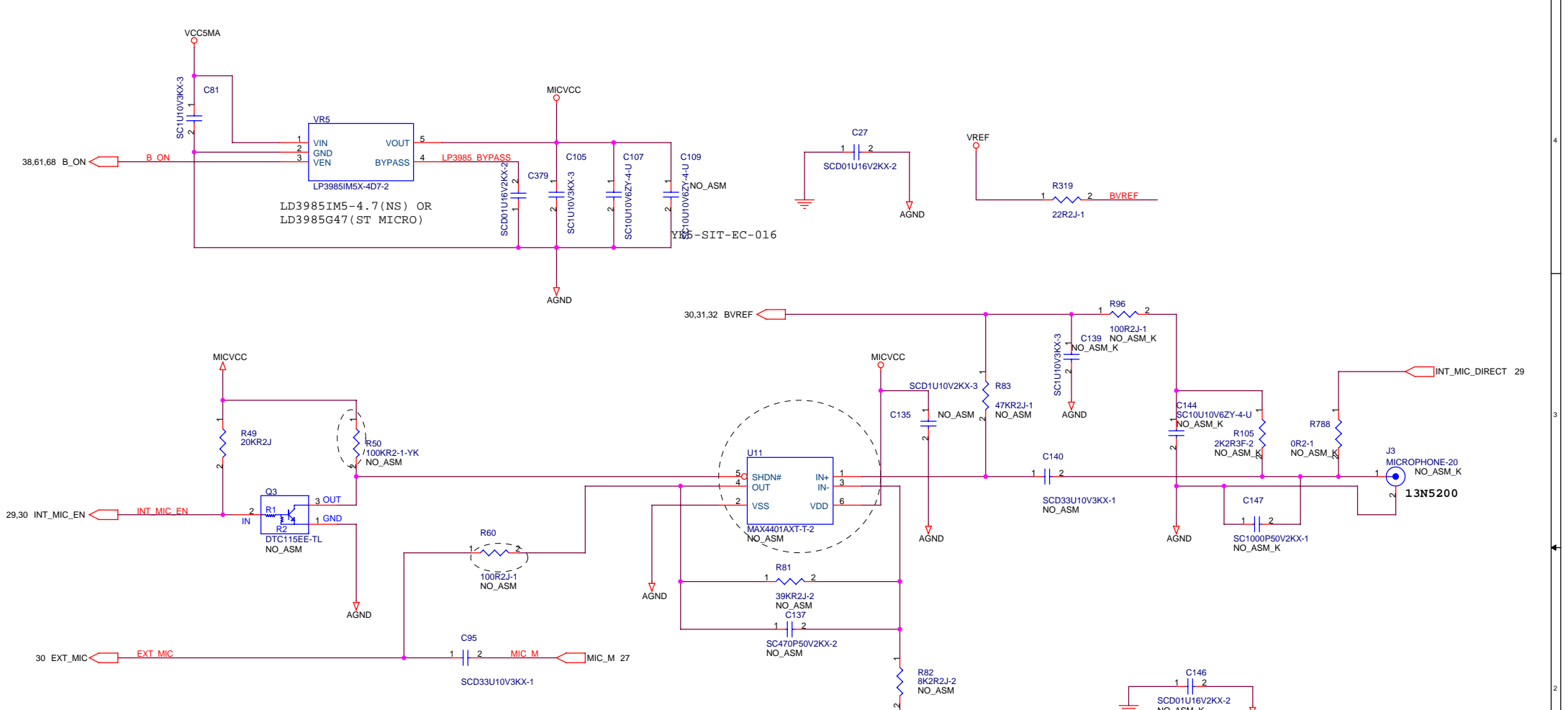

	Y-NOTE	K-NOTE
R50	NO_ASM	NO_ASM
Q3	NO_ASM	NO_ASM
R60	NO_ASM	NO_ASM
U11	NO_ASM	NO_ASM
R81	NO_ASM	NO_ASM
C137	NO_ASM	NO_ASM
R82	NO_ASM	NO_ASM
C138	NO_ASM	NO_ASM
C140	NO_ASM	NO_ASM
C135	NO_ASM	NO_ASM
C139	ASM	NO_ASM
R96	ASM	NO_ASM
R83	NO_ASM	NO_ASM
C144	ASM	NO_ASM
R105	ASM	NO_ASM
R788	ASM	NO_ASM
C147	ASM	NO_ASM
C146	ASM	NO_ASM
J3	ASM	NO_ASM

ALL PARTS MUST BE PLACED NEAR INTERNAL MICROPHONE

**緯創資通 Wistron Corporation**  
 21F, 88, Sec.1, Hsin Tai Wj Rd., Hsichih,  
 Taipei Hsien 221, Taiwan, R.O.C.

---

Title: **AUDIO INT MIC**

Size: A3	Document Number: <b>Y Note-5</b>	Rev: -2
----------	----------------------------------	---------

Date: Tuesday, December 28, 2004 Sheet 28 of 71

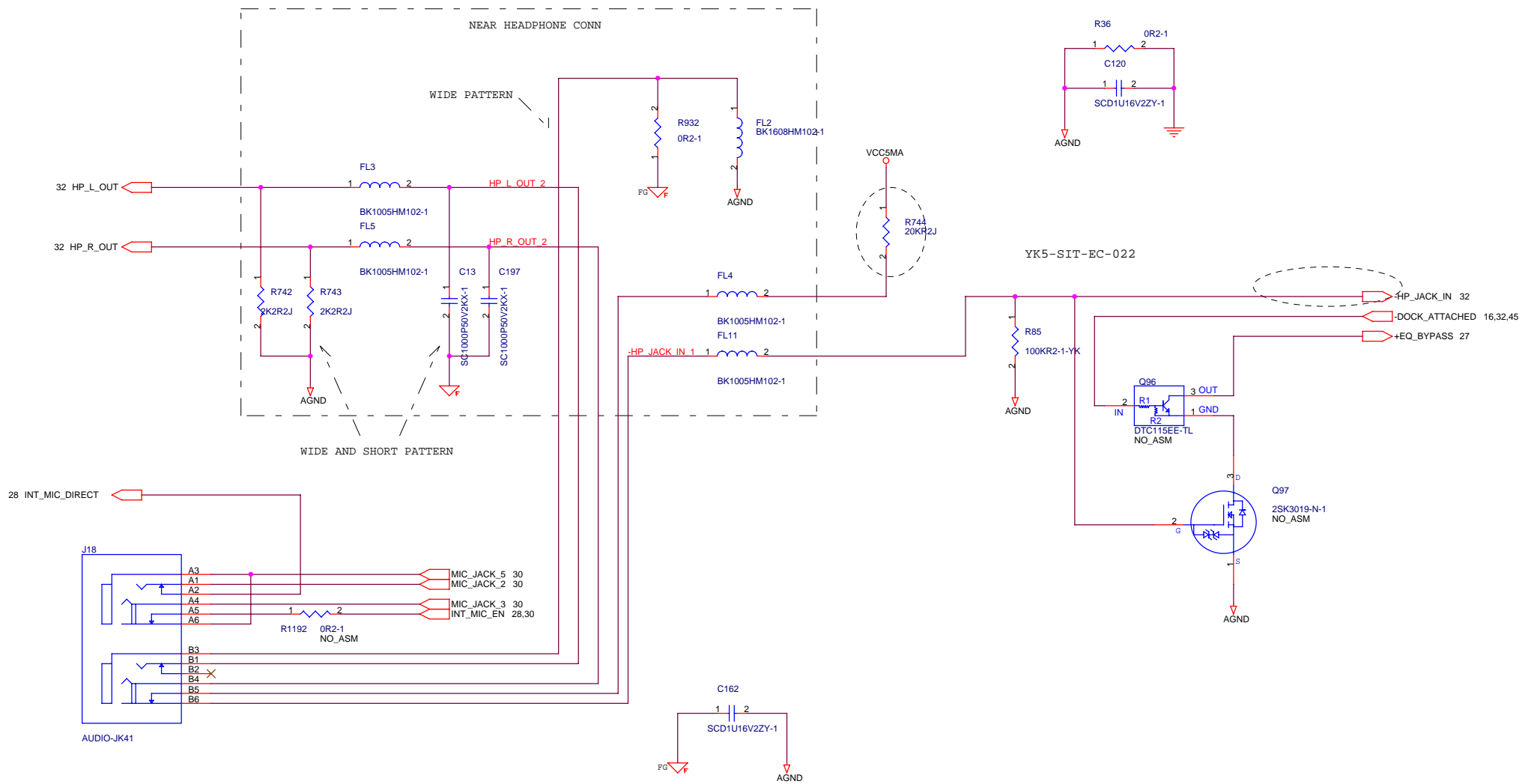

Q96	K-NOTE	Y-NOTE
Q97	NO_ASM	NO_ASM

**緯創資通 Wistron Corporation**  
 21F, 88, Sec.1, Hsin Tai WJ Rd., Hsichih,  
 Taipei Hsien 221, Taiwan, R.O.C.

Title: **AUDIO HP & EXT MIC AMP**

Size: A3 Document Number: **Y Note-5** Rev: -2

Date: Tuesday, December 28, 2004 Sheet: 29 of 71

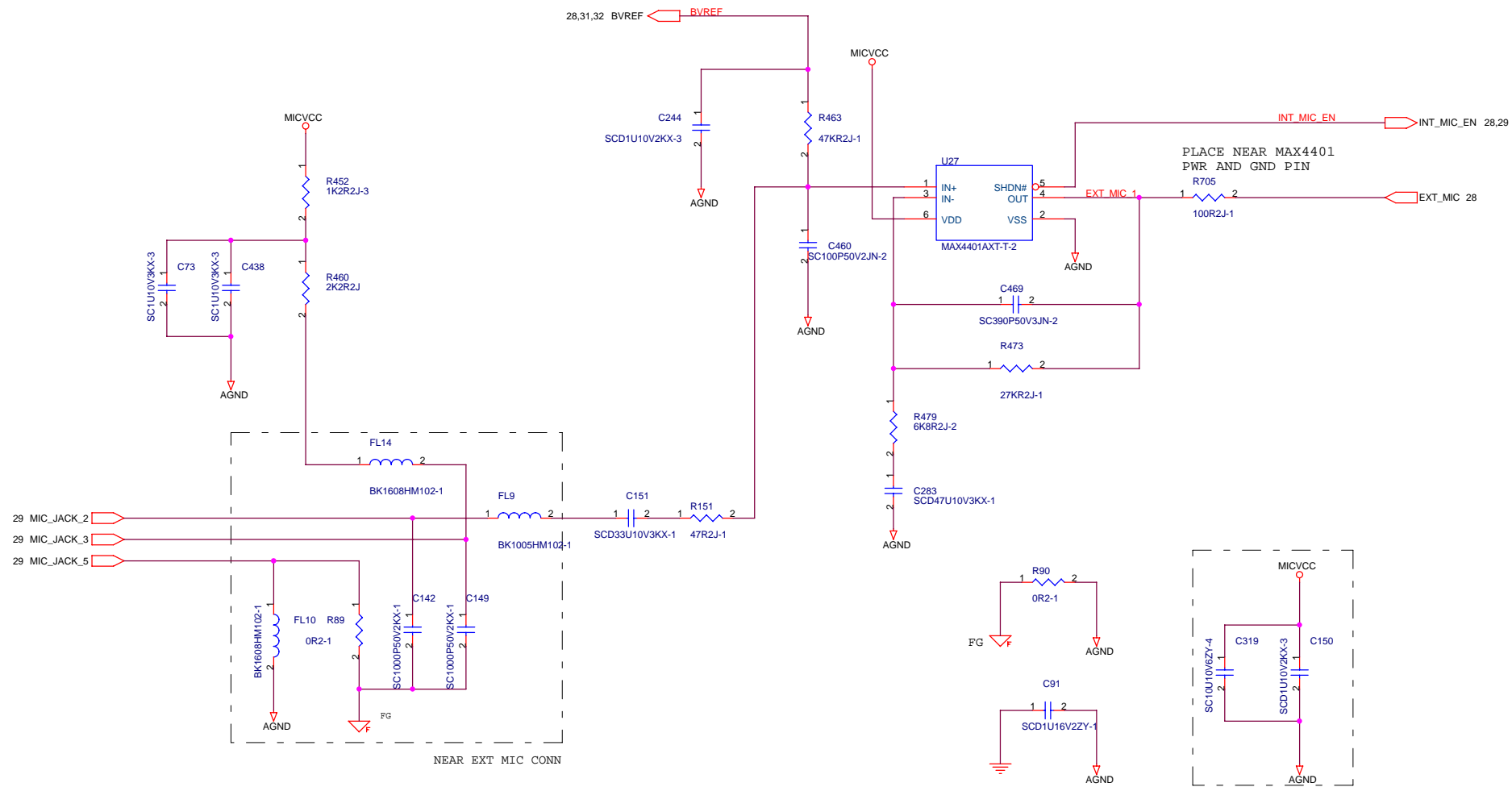

	K-NOTE	Y-NOTE
R59	NO_ASM	ASM
R57	NO_ASM	ASM
R63	NO_ASM	ASM
R58	NO_ASM	ASM
C63	NO_ASM	ASM
C75	NO_ASM	ASM

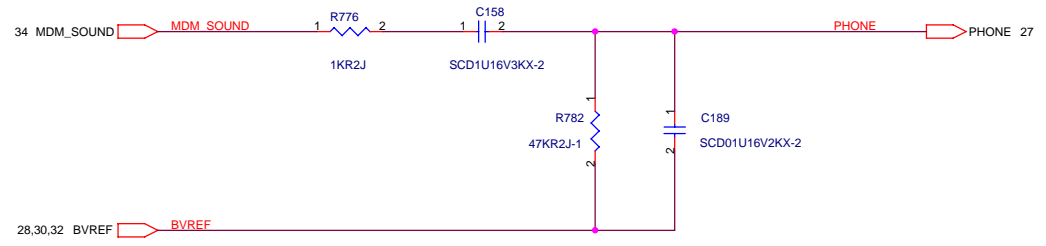
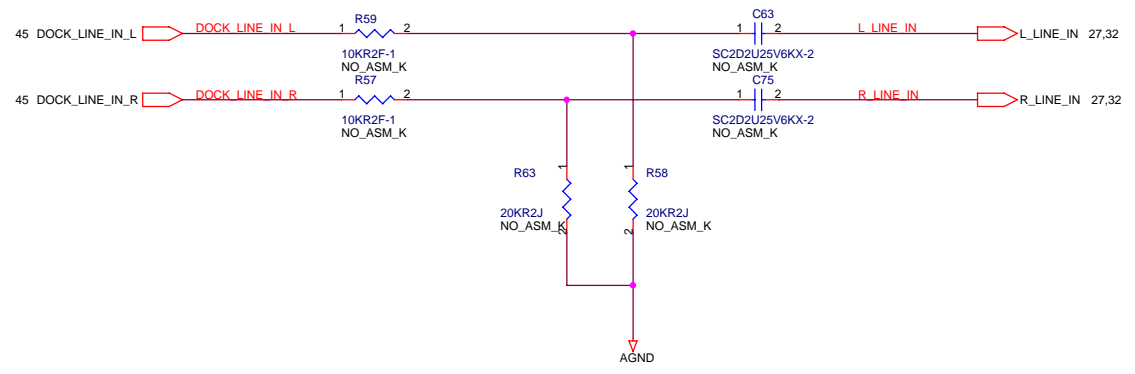
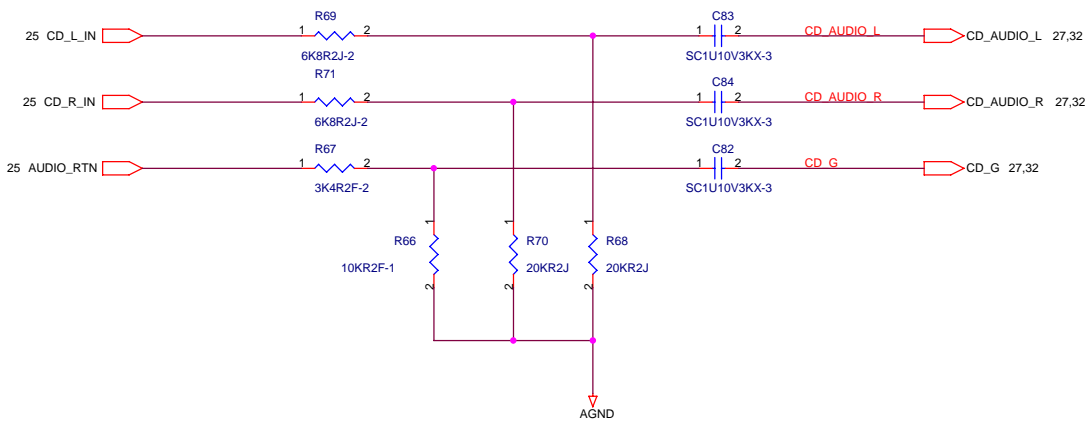

<b>緯創資通</b>		<b>Wistron Corporation</b>	
		21F, 88, Sec.1, Hsin Tai WJ Rd., Hsichih, Taipei Hsien 221, Taiwan, R.O.C.	
Title			
<b>AUDIO MISC</b>			
Size	Document Number	Rev	
A3		<b>Y Note-5</b>	-2
Date: Tuesday, December 28, 2004		Sheet	31 of 71

	Y-NOTE	K-NOTE
C981	NO_ASM	NO_ASM
C982	NO_ASM	NO_ASM
C89	ASM	NO_ASM
C32	ASM	NO_ASM

	STEREO	MONO
C1086	NO_ASM	ASM
R1067	ASM	NO_ASM
R1068	NO_ASM	ASM
R679	24KOHM	47KOHM
R680	24KOHM	47KOHM
R1065	ASM	NO_ASM
R1066	ASM	NO_ASM

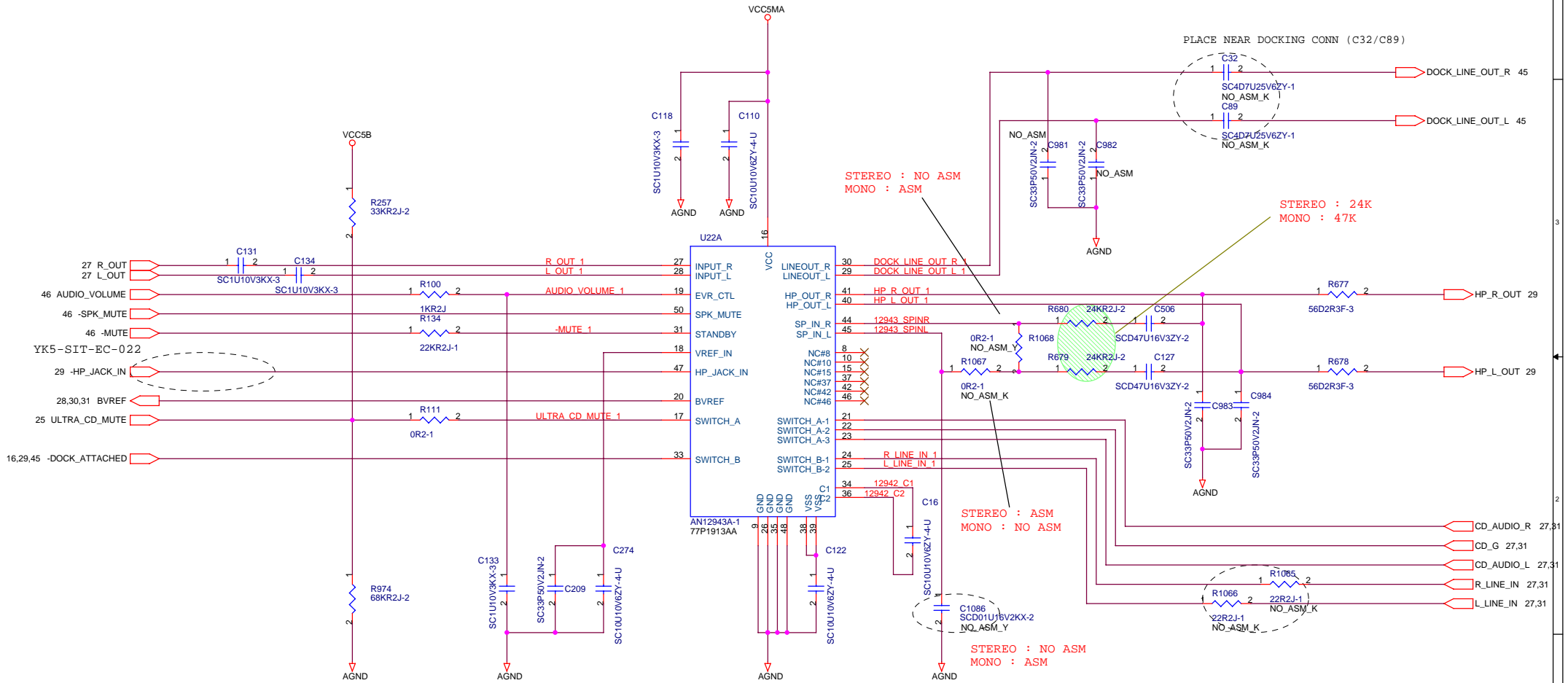

**緯創資通 Wistron Corporation**  
 21F, 88, Sec.1, Hsin Tai Wj Rd., Hsichih,  
 Taipei Hsien 221, Taiwan, R.O.C.

Title		<b>AUDIO HDP AMP AN12943A (1/2)</b>	
Size	Document Number	Y Note-5	
A3		Rev -2	
Date: Tuesday, December 28, 2004		Sheet 32 of 71	



	K-NOTE	Y-NOTE
C550	NO_ASM	ASM
R488	NO_ASM	ASM

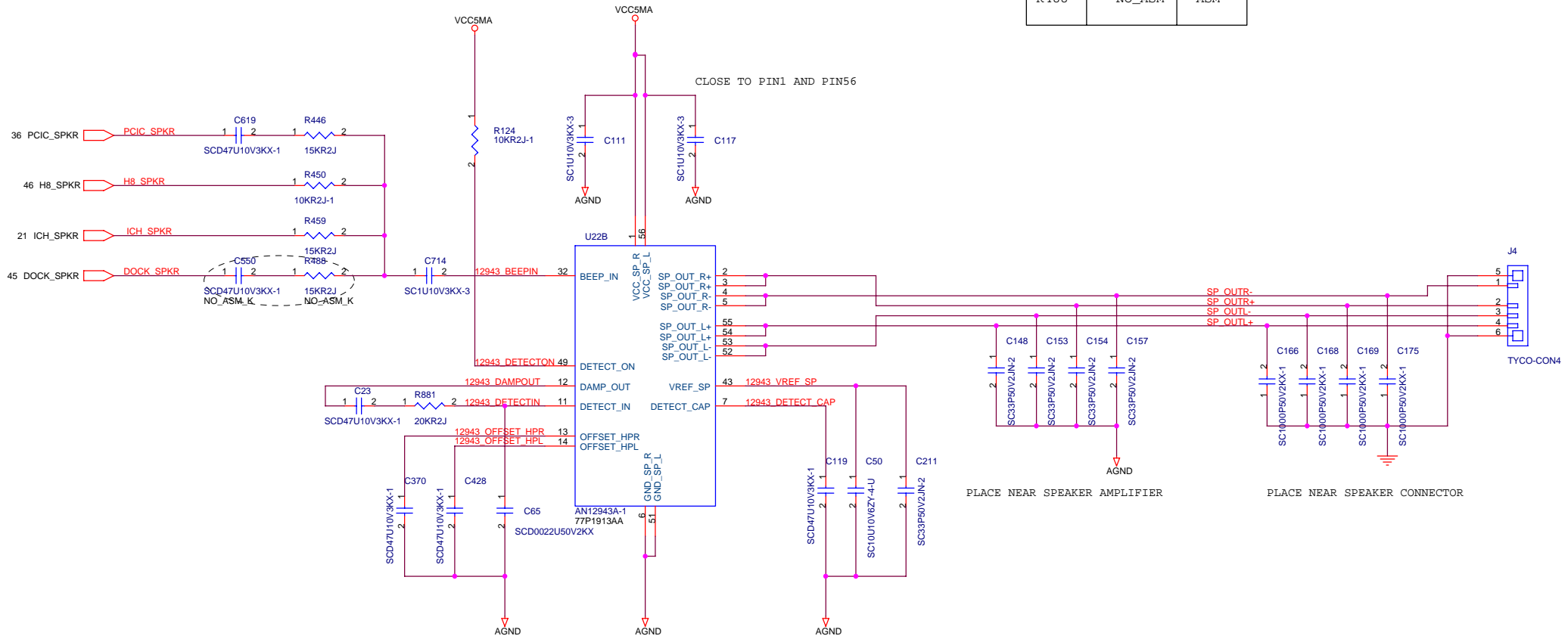

**緯創資通 Wistron Corporation**  
 21F, 88, Sec.1, Hsin Tai WJ Rd., Hsichih,  
 Taipei Hsien 221, Taiwan, R.O.C.

Title		AUDIO HDP AMP AN12943A (1/2)	
Size	Document Number	Rev	
A3		-2	
Date: Tuesday, December 28, 2004		Sheet	71
		33	of

Y Note-5

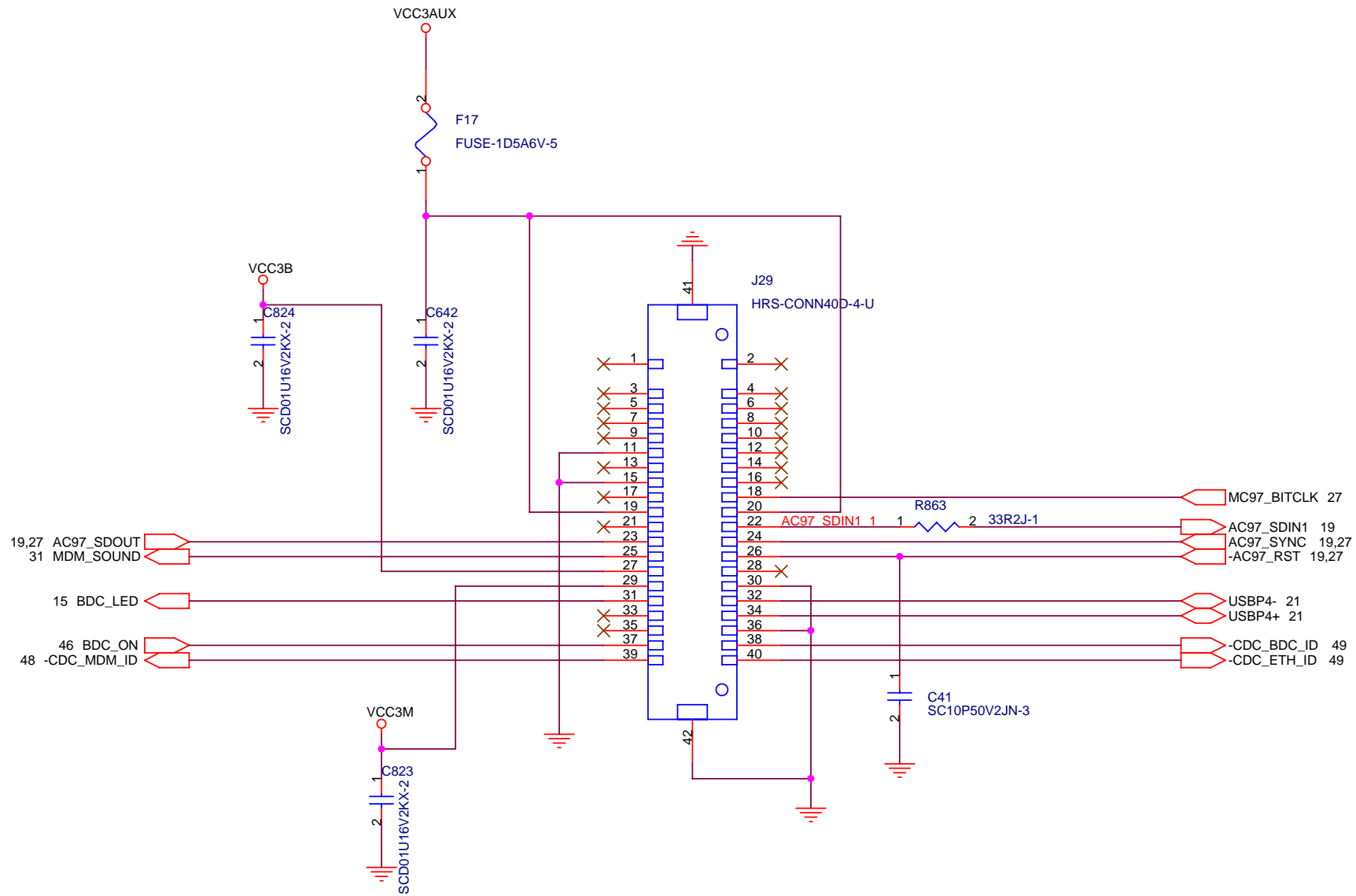

**緯創資通** **Wistron Corporation**  
 21F, 88, Sec.1, Hsin Tai Wu Rd., Hsichih,  
 Taipei Hsien 221, Taiwan, R.O.C.

Title		
<b>CDC CONNECTOR</b>		
Size A4	Document Number <b>Y Note-5</b>	Rev -2
Date: Tuesday, December 28, 2004	Sheet 34 of 71	

	Y-NOTE	K-NOTE
C1183	NO_ASM	NO_ASM
C1184	NO_ASM	NO_ASM

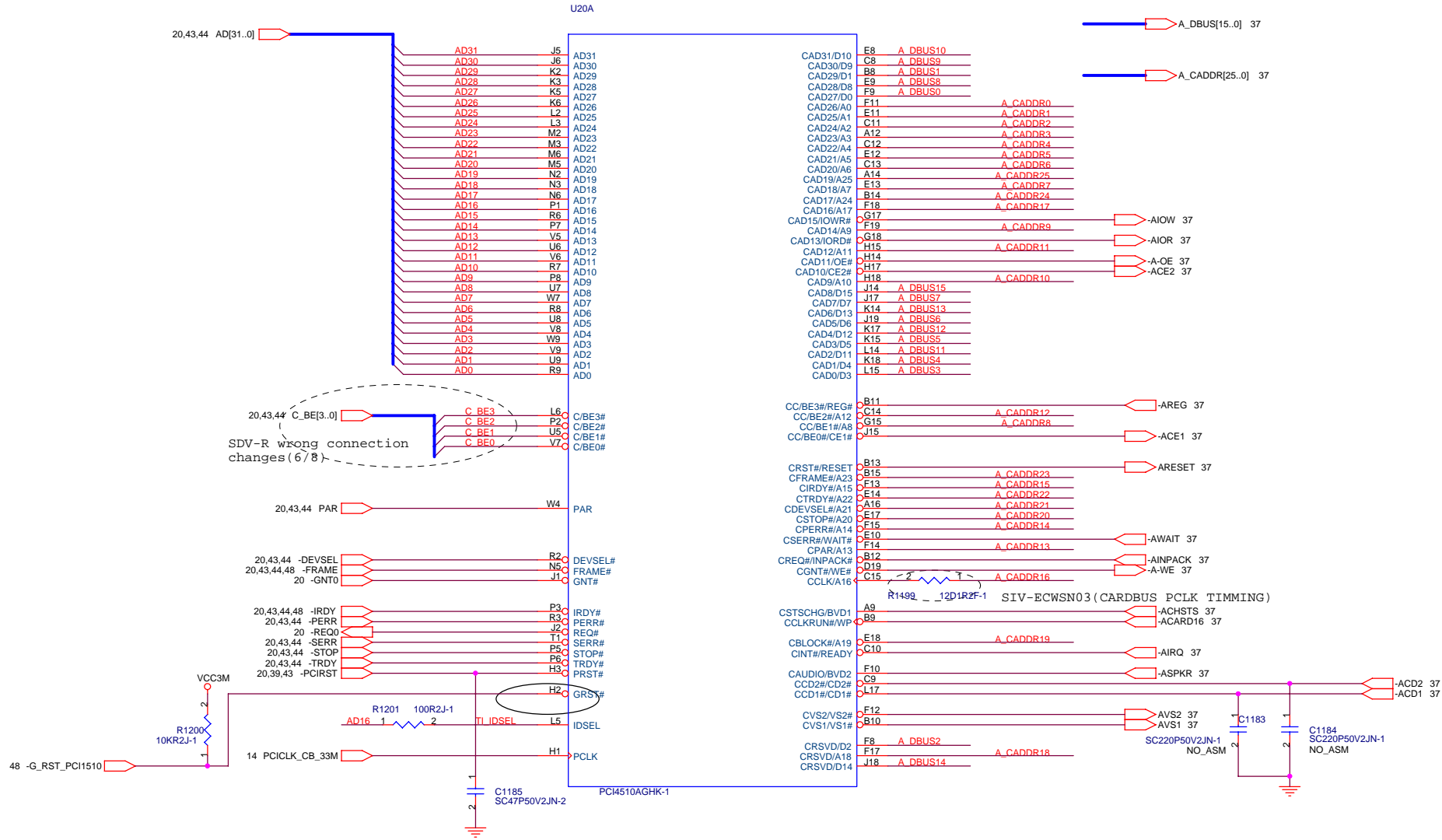

**緯創資通 Wistron Corporation**  
 21F, 88, Sec.1, Hsin Tai WJ Rd., Hsichih,  
 Taipei Hsien 221, Taiwan, R.O.C.

Title		
<b>CARDBUS(1/2)</b>		
Size	Document Number	Rev
A3	<b>Y Note-5</b>	-2
Date: Tuesday, December 28, 2004		Sheet 35 of 71

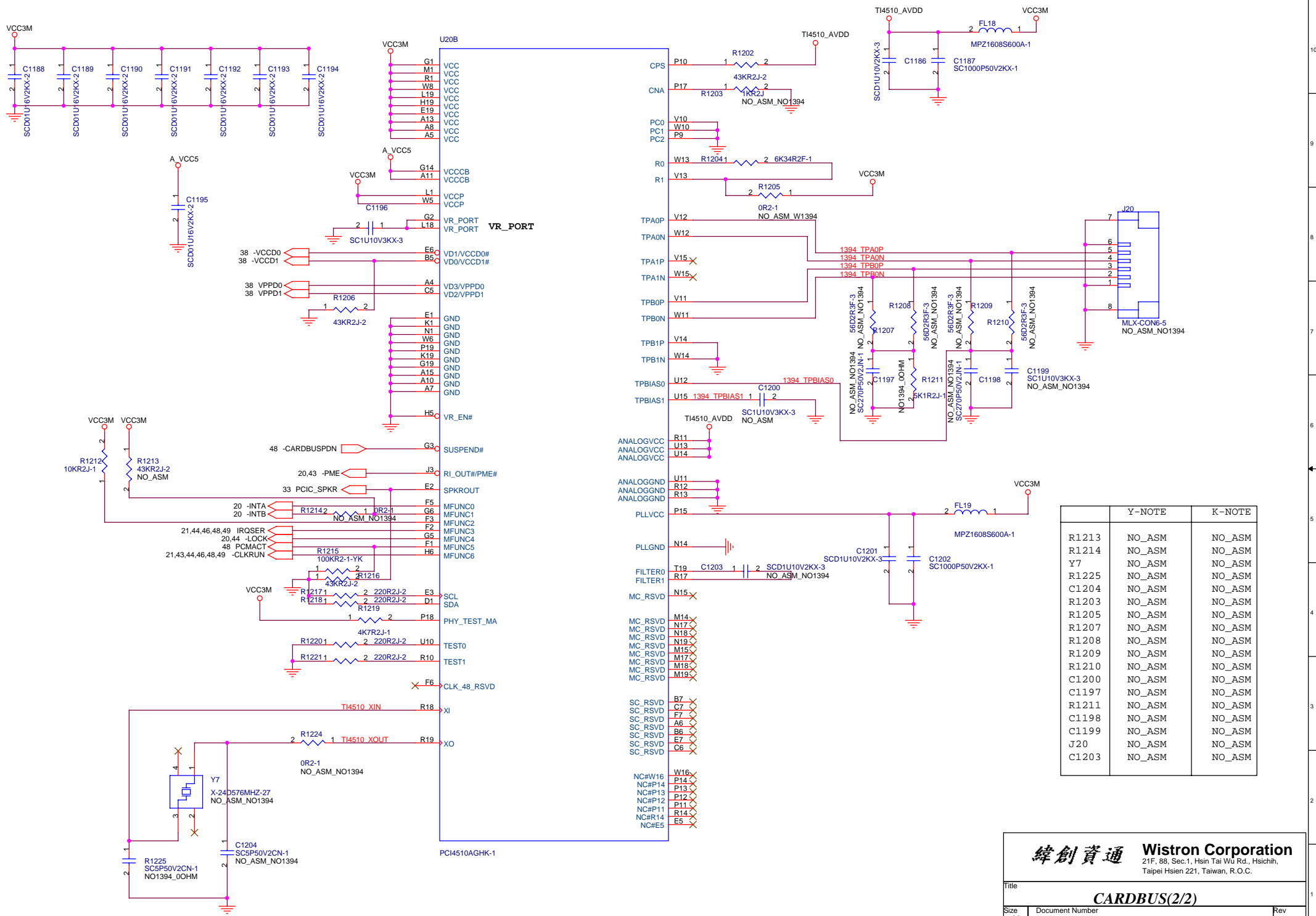

	Y-NOTE	K-NOTE
R1213	NO_ASM	NO_ASM
R1214	NO_ASM	NO_ASM
Y7	NO_ASM	NO_ASM
R1225	NO_ASM	NO_ASM
C1204	NO_ASM	NO_ASM
R1203	NO_ASM	NO_ASM
R1205	NO_ASM	NO_ASM
R1207	NO_ASM	NO_ASM
R1208	NO_ASM	NO_ASM
R1209	NO_ASM	NO_ASM
R1210	NO_ASM	NO_ASM
C1200	NO_ASM	NO_ASM
C1197	NO_ASM	NO_ASM
R1211	NO_ASM	NO_ASM
C1198	NO_ASM	NO_ASM
C1199	NO_ASM	NO_ASM
J20	NO_ASM	NO_ASM
C1203	NO_ASM	NO_ASM

**緯創資通 Wistron Corporation**  
 21F, 88, Sec.1, Hsin Tai WJ Rd., Hsichih,  
 Taipei Hsien 221, Taiwan, R.O.C.

Title: **CARBUS(2/2)**

Size: A3 Document Number: **Y Note-5** Rev: -2

Date: Tuesday, December 28, 2004 Sheet: 36 of 71

	Y-NOTE	K-NOTE
R109	NO_ASM	NO_ASM
C431	NO_ASM	NO_ASM

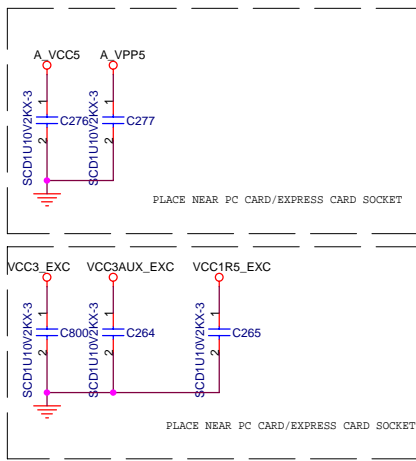
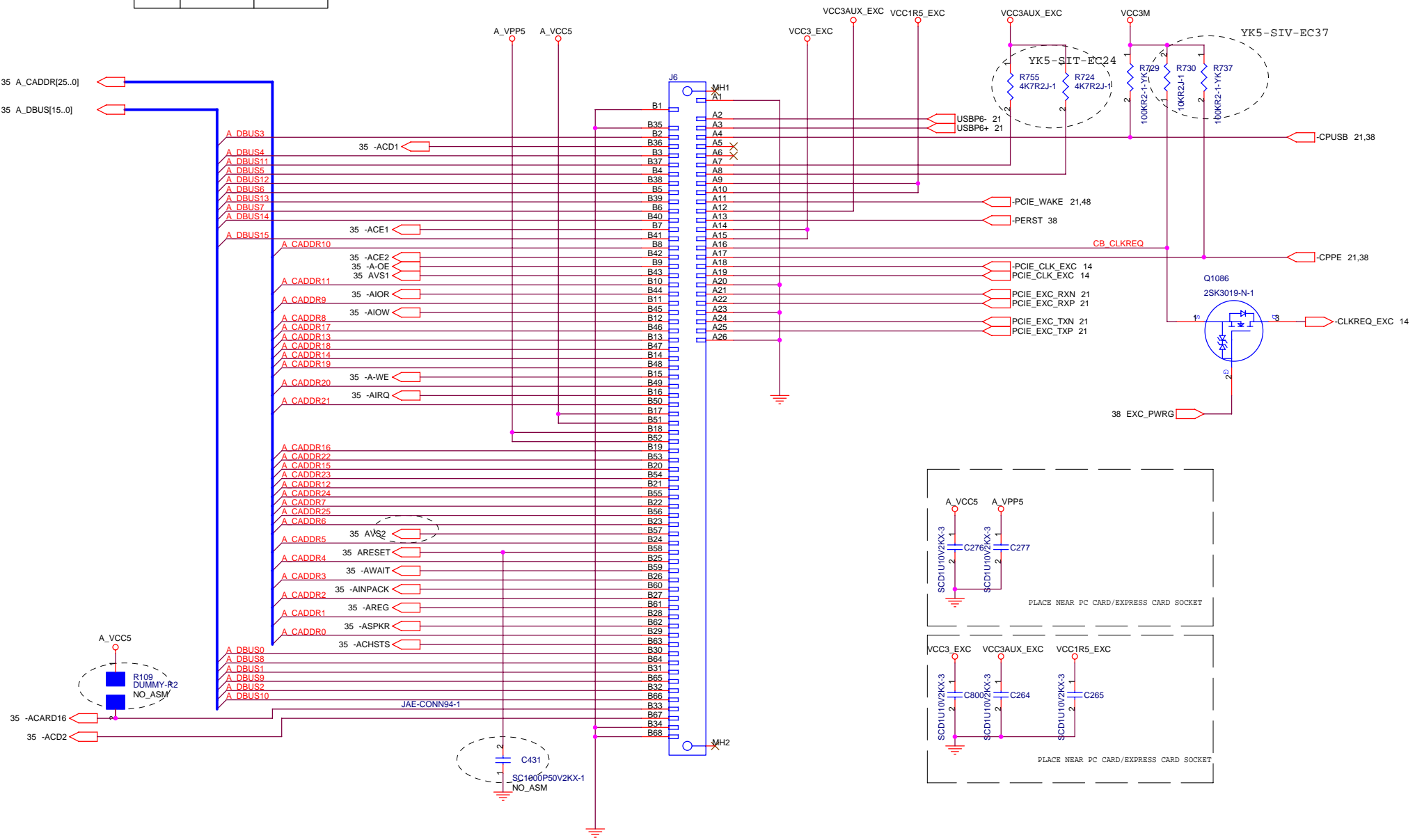

**緯創資通 Wistron Corporation**  
 21F, 88, Sec.1, Hsin Tai WJ Rd., Hsichih,  
 Taipei Hsien 221, Taiwan, R.O.C.

Title: **CARDBUS/EXPRESS CARD SLOT**

Size: Custom	Document Number: <b>Y Note-5</b>	Rev: -2
--------------	----------------------------------	---------

Date: Tuesday, December 28, 2004 Sheet 37 of 71

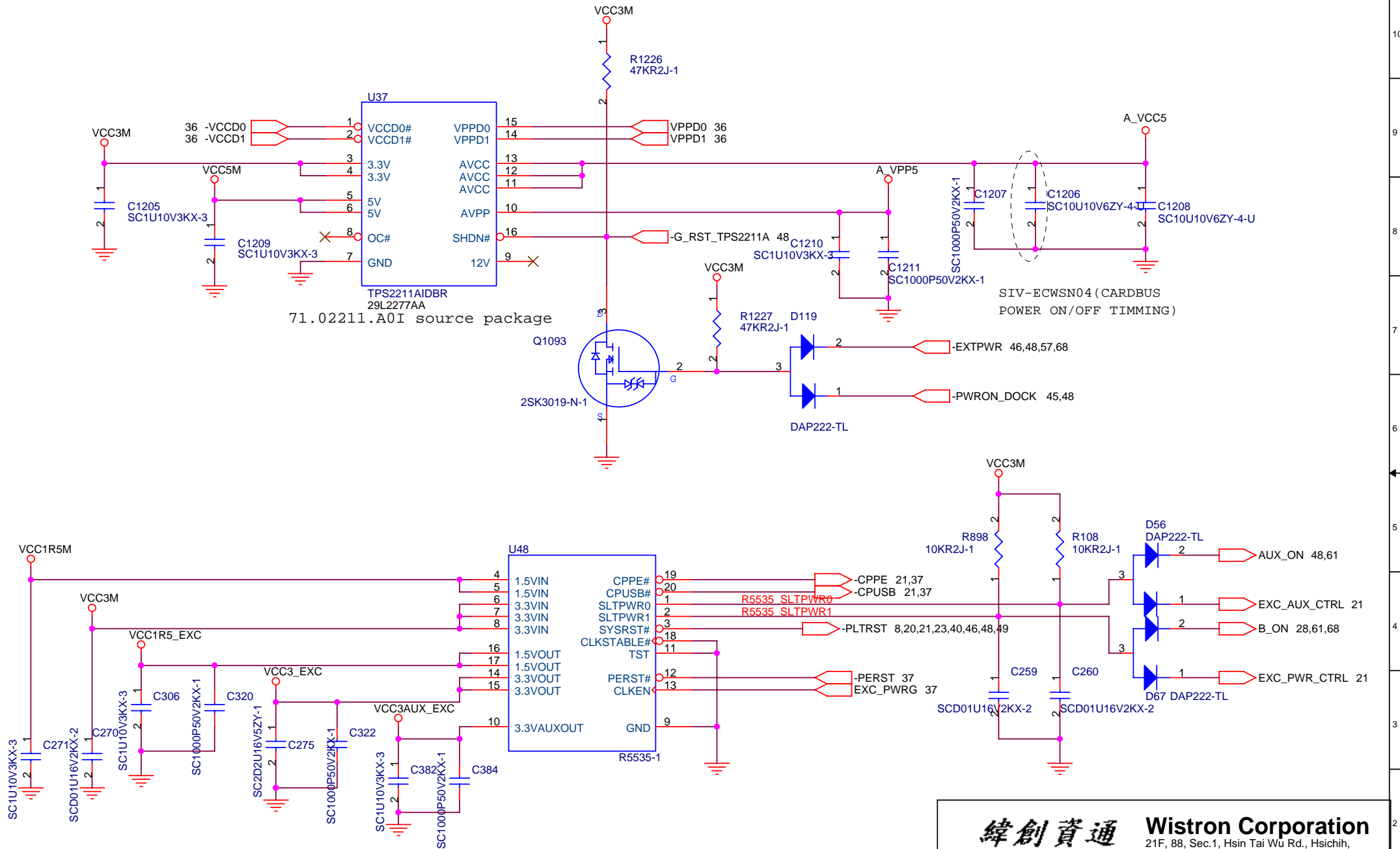

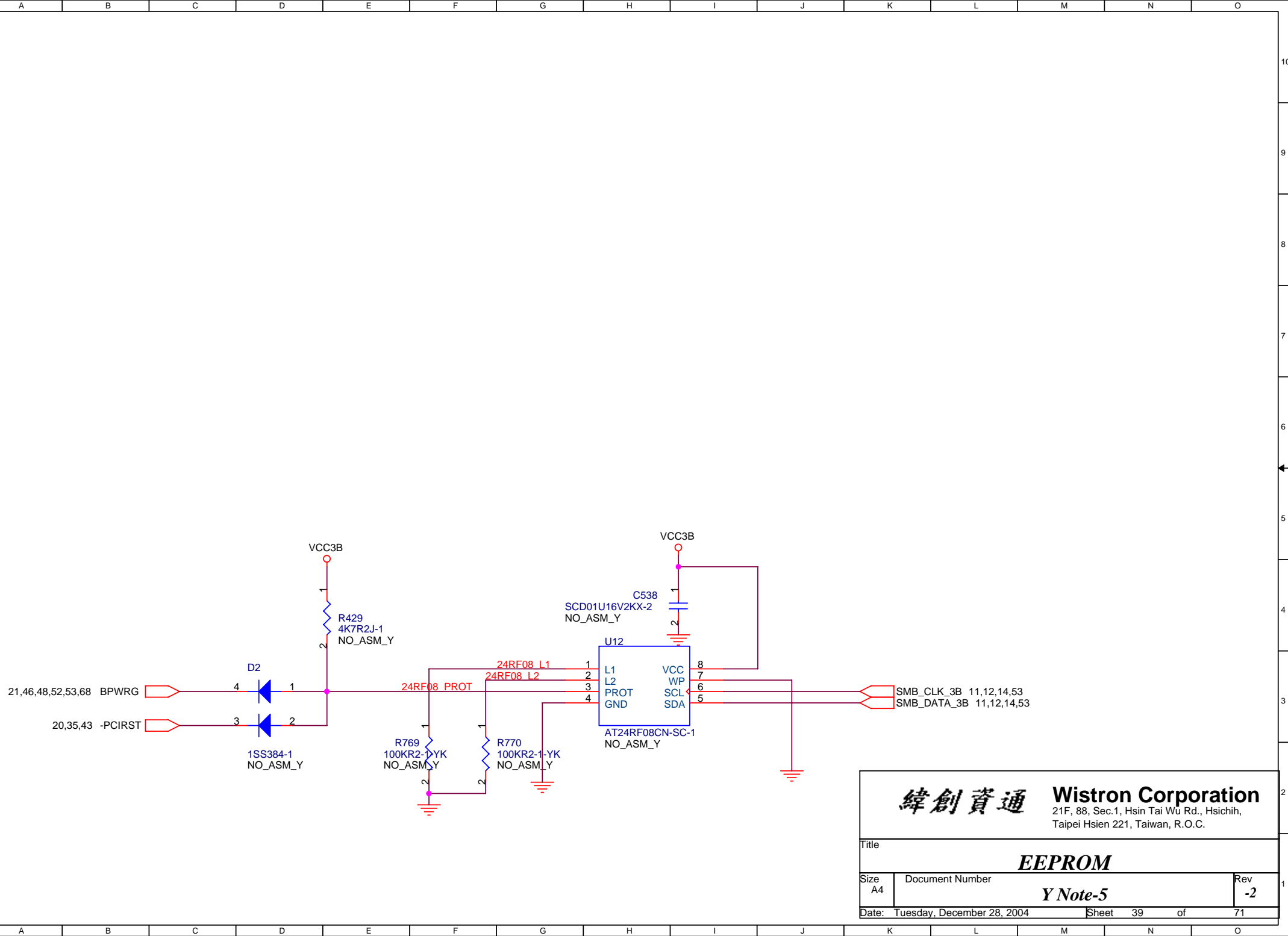

**Wistron Corporation**  
 21F, 88, Sec.1, Hsin Tai Wu Rd., Hsichih,  
 Taipei Hsien 221, Taiwan, R.O.C.

Title		
<b>CARDBUS POWER CONTROL</b>		
Size A4	Document Number	Rev -2
Date: Tuesday, December 28, 2004		Sheet 38 of 71

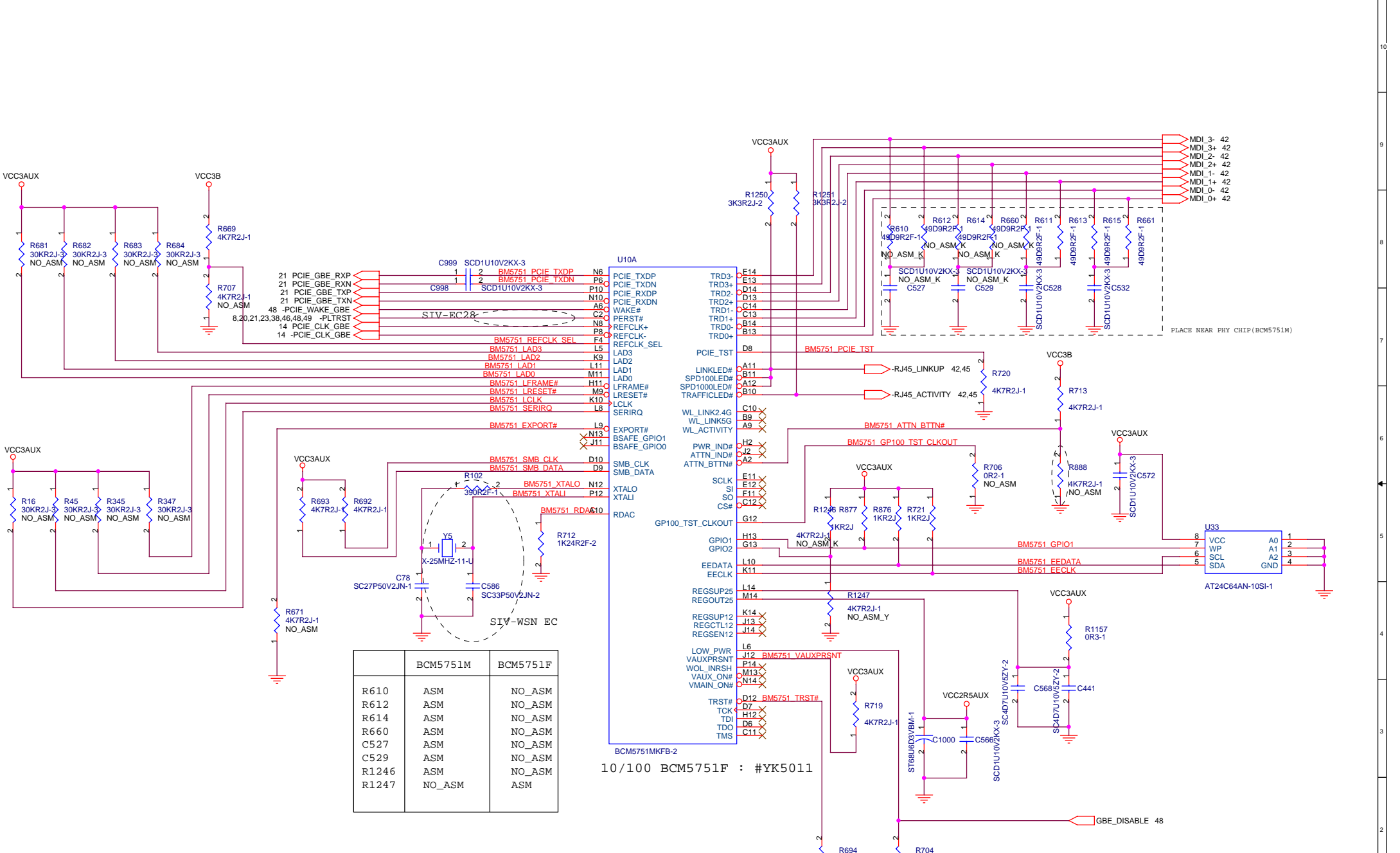

**緯創資通** **Wistron Corporation**  
 21F, 88, Sec.1, Hsin Tai Wu Rd., Hsichih,  
 Taipei Hsien 221, Taiwan, R.O.C.

Title		
<b>EEPROM</b>		
Size A4	Document Number	Rev -2
Date: Tuesday, December 28, 2004		Sheet 39 of 71



	BCM5751M	BCM5751F
R610	ASM	NO_ASM
R612	ASM	NO_ASM
R614	ASM	NO_ASM
R660	ASM	NO_ASM
C527	ASM	NO_ASM
C529	ASM	NO_ASM
R1246	ASM	NO_ASM
R1247	NO_ASM	ASM

10/100 BCM5751F : #YK5011

**緯創資通 Wistron Corporation**  
 21F, 88, Sec.1, Hsin Tai Wj Rd., Hsichih,  
 Taipei Hsien 221, Taiwan, R.O.C.

**GBE(I/2)**

Title \_\_\_\_\_

Size A3 Document Number \_\_\_\_\_ Rev -2

Date: Tuesday, December 28, 2004 Sheet 40 of 71



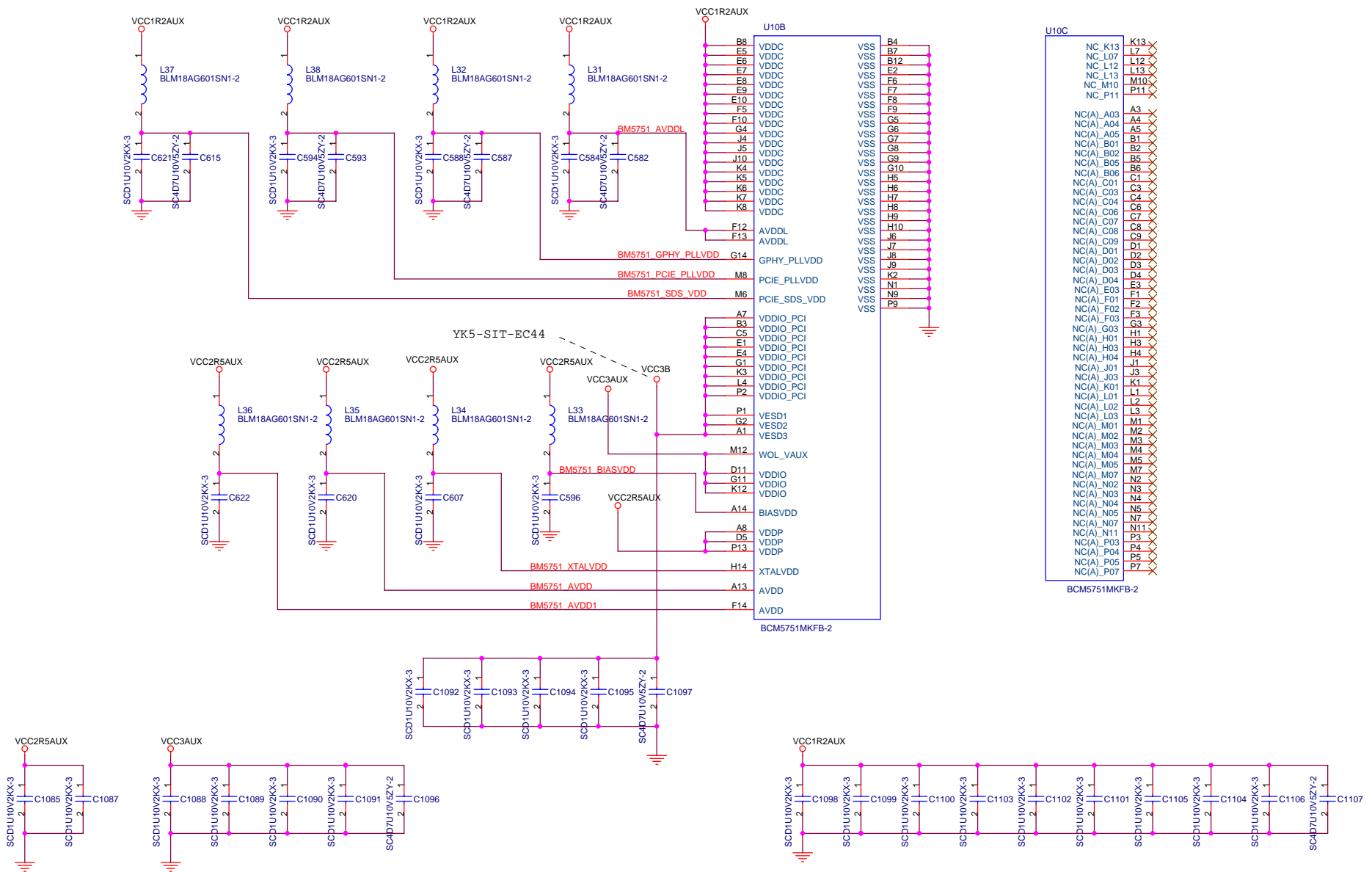

U10C	K13	K13
NC_K13	L7	X
NC_L07	L12	X
NC_L12	L13	X
NC_L13	M10	X
NC_M10	P11	X
NC_P11		
NC(A)_A03	A3	X
NC(A)_A04	A4	X
NC(A)_A05	A5	X
NC(A)_B01	B1	X
NC(A)_B02	B2	X
NC(A)_B05	B5	X
NC(A)_B06	B6	X
NC(A)_C01	C1	X
NC(A)_C03	C3	X
NC(A)_C04	C4	X
NC(A)_C06	C6	X
NC(A)_C07	C7	X
NC(A)_C08	C8	X
NC(A)_C09	C9	X
NC(A)_D01	D1	X
NC(A)_D02	D2	X
NC(A)_D03	D3	X
NC(A)_D04	D4	X
NC(A)_E03	E3	X
NC(A)_F01	F1	X
NC(A)_F02	F2	X
NC(A)_F03	F3	X
NC(A)_G03	G3	X
NC(A)_H01	H1	X
NC(A)_H03	H3	X
NC(A)_H04	H4	X
NC(A)_J01	J1	X
NC(A)_J03	J3	X
NC(A)_K01	K1	X
NC(A)_L01	L1	X
NC(A)_L02	L2	X
NC(A)_L03	L3	X
NC(A)_M01	M1	X
NC(A)_M02	M2	X
NC(A)_M03	M3	X
NC(A)_M04	M4	X
NC(A)_M05	M5	X
NC(A)_M07	M7	X
NC(A)_N02	N2	X
NC(A)_N03	N3	X
NC(A)_N04	N4	X
NC(A)_N05	N5	X
NC(A)_N07	N7	X
NC(A)_N11	N11	X
NC(A)_P03	P3	X
NC(A)_P04	P4	X
NC(A)_P05	P5	X
NC(A)_P07	P7	X

BCM5751MKFB-2

**緯創資通 Wistron Corporation**  
 21F, 88, Sec.1, Hsin Tai WJ Rd., Hsichih,  
 Taipei Hsien 221, Taiwan, R.O.C.

Title		
<b>GBE(2/2)</b>		
Size	Document Number	Rev
A3	<b>Y Note-5</b>	-2
Date: Tuesday, December 28, 2004		
Sheet		of
41		71

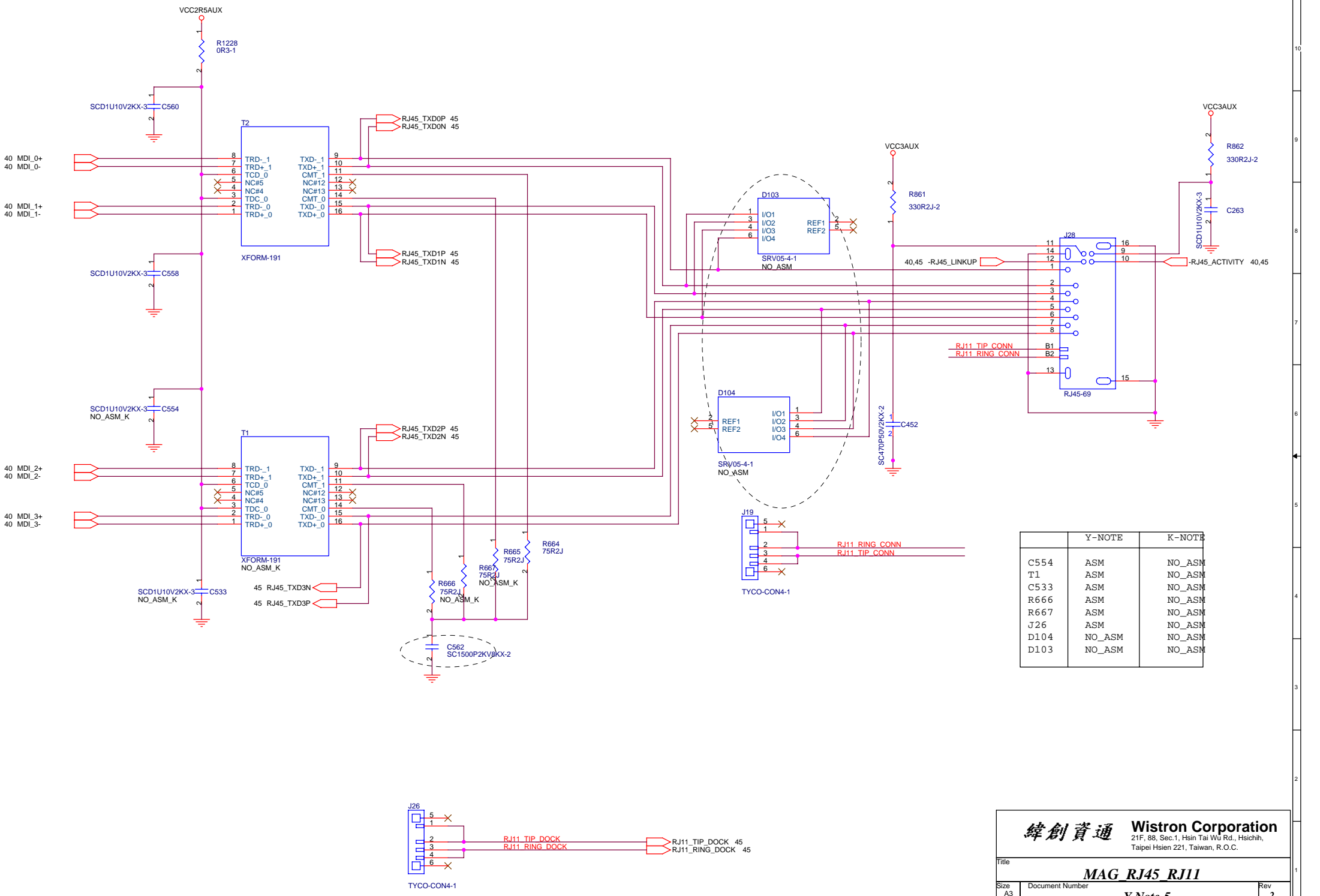

	Y-NOTE	K-NOTE
C554	ASM	NO_ASM
T1	ASM	NO_ASM
C533	ASM	NO_ASM
R666	ASM	NO_ASM
R667	ASM	NO_ASM
J26	ASM	NO_ASM
D104	NO_ASM	NO_ASM
D103	NO_ASM	NO_ASM

**緯創資通 Wistron Corporation**  
 21F, 88, Sec.1, Hsin Tai Wj Rd., Hsichih,  
 Taipei Hsien 221, Taiwan, R.O.C.

Title: **MAG RJ45 RJ11**

Size: A3	Document Number: <b>Y Note-5</b>	Rev: -2
----------	----------------------------------	---------

Date: Tuesday, December 28, 2004 Sheet 42 of 71

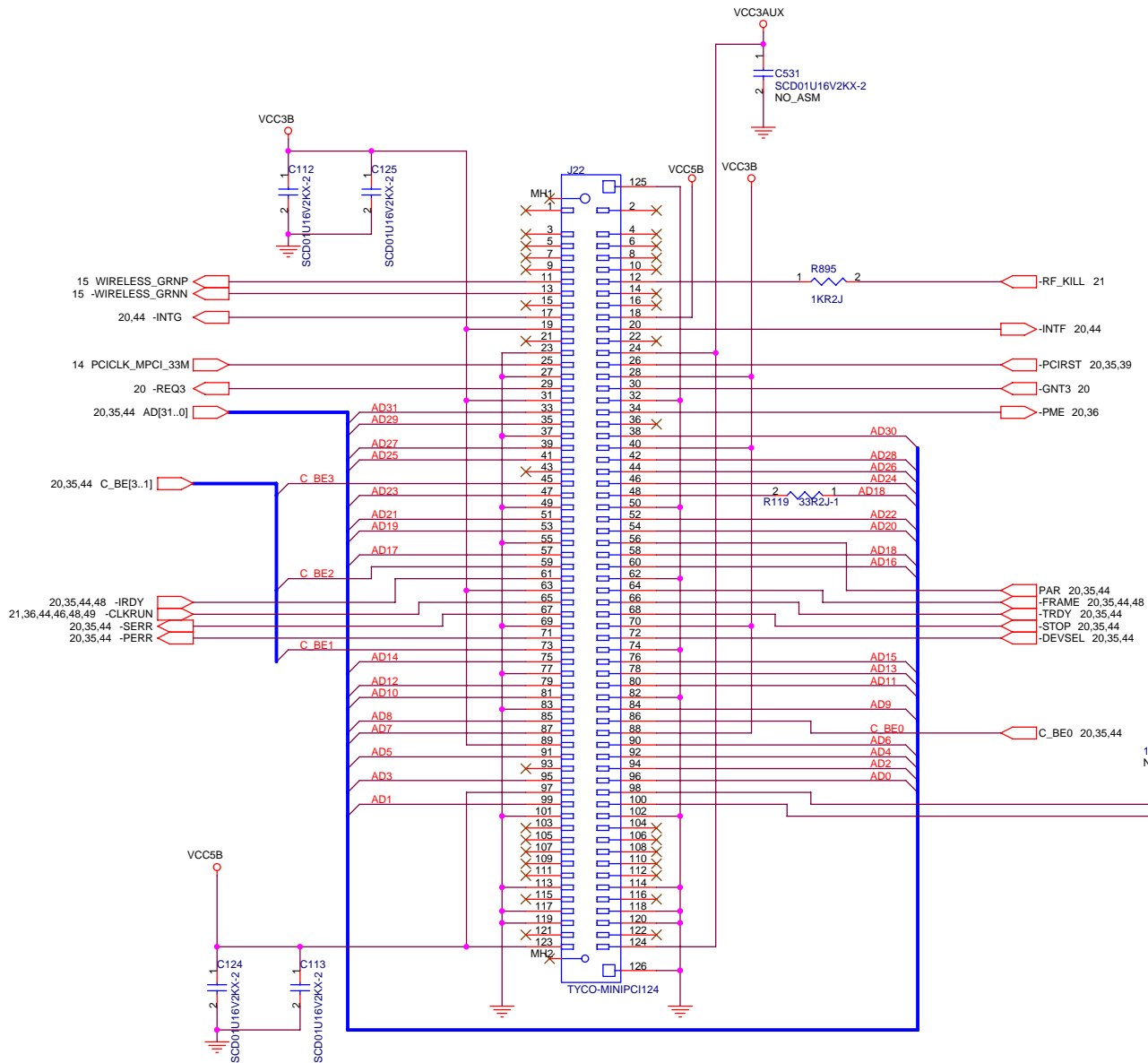

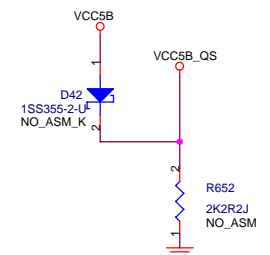
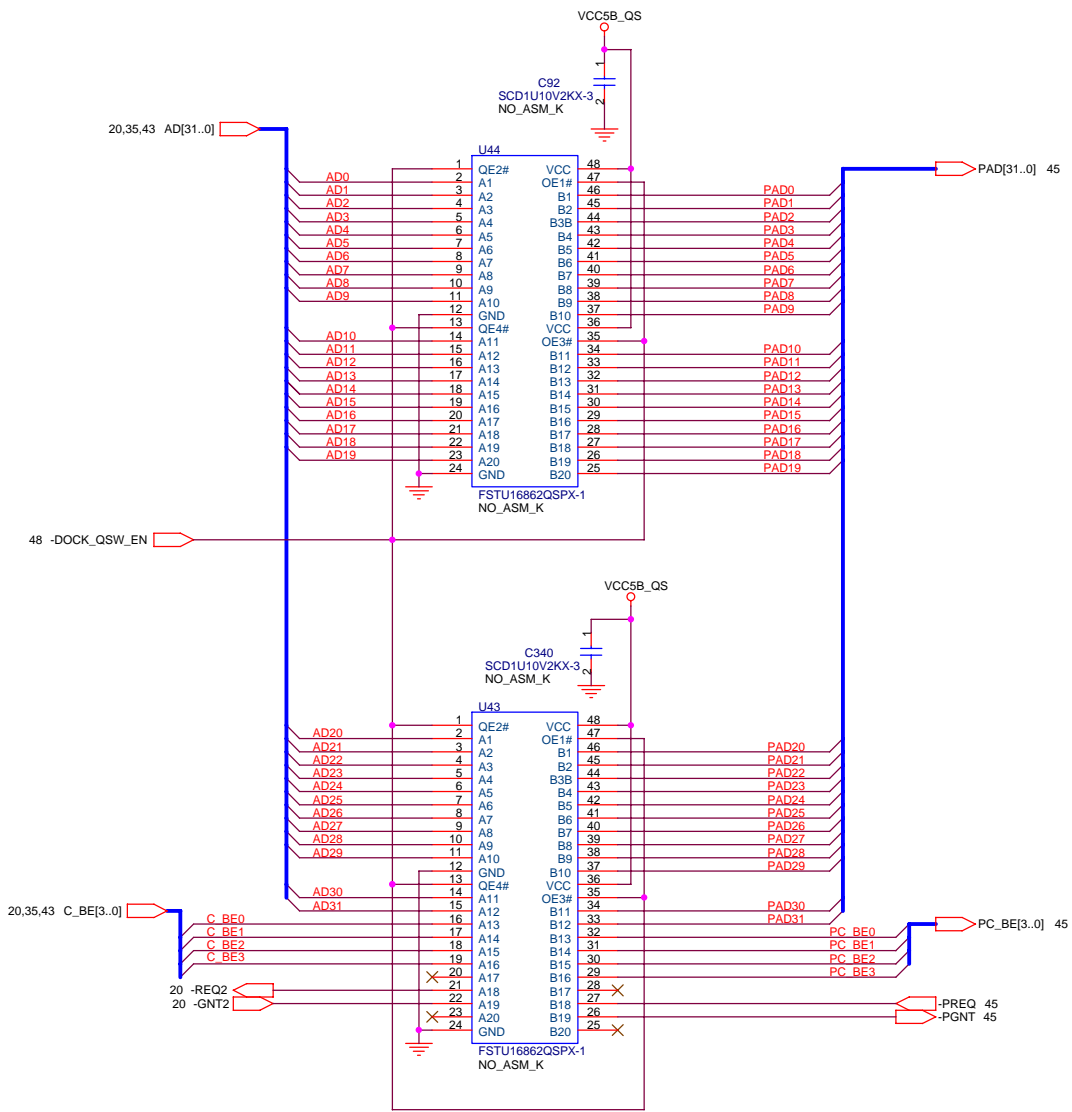

	Y-NOTE	K-NOTE
C92	ASM	NO_ASM
C340	ASM	NO_ASM
D42	ASM	NO_ASM
R652	NO_ASM	NO_ASM
C345	ASM	NO_ASM
U44	ASM	NO_ASM
U43	ASM	NO_ASM

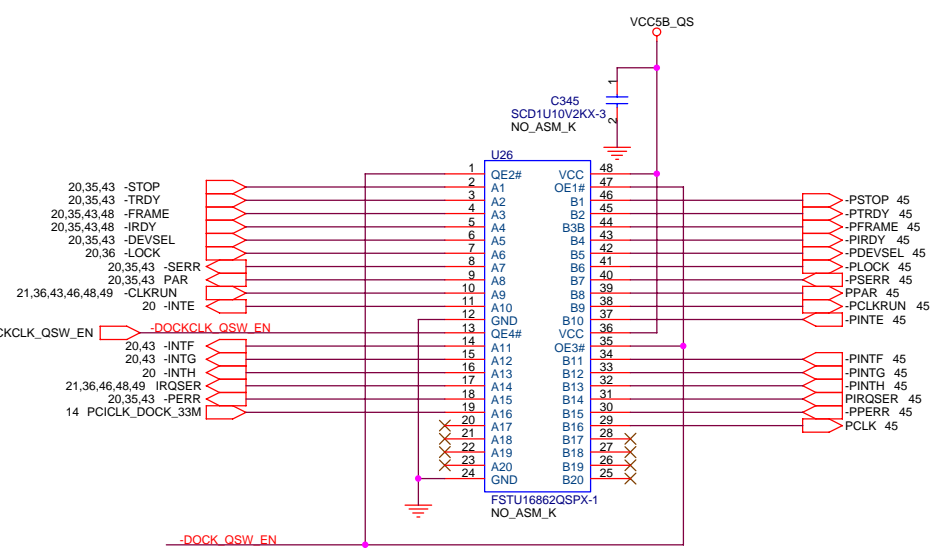

**緯創資通 Wistron Corporation**  
 21F, 88, Sec.1, Hsin Tai Wj Rd., Hsichih,  
 Taipei Hsien 221, Taiwan, R.O.C.

**PCI BUS SWITCH**

Title: \_\_\_\_\_

Size: A3    Document Number: \_\_\_\_\_    Rev: -2

**Y Note-5**

Date: Tuesday, December 28, 2004    Sheet 44 of 71

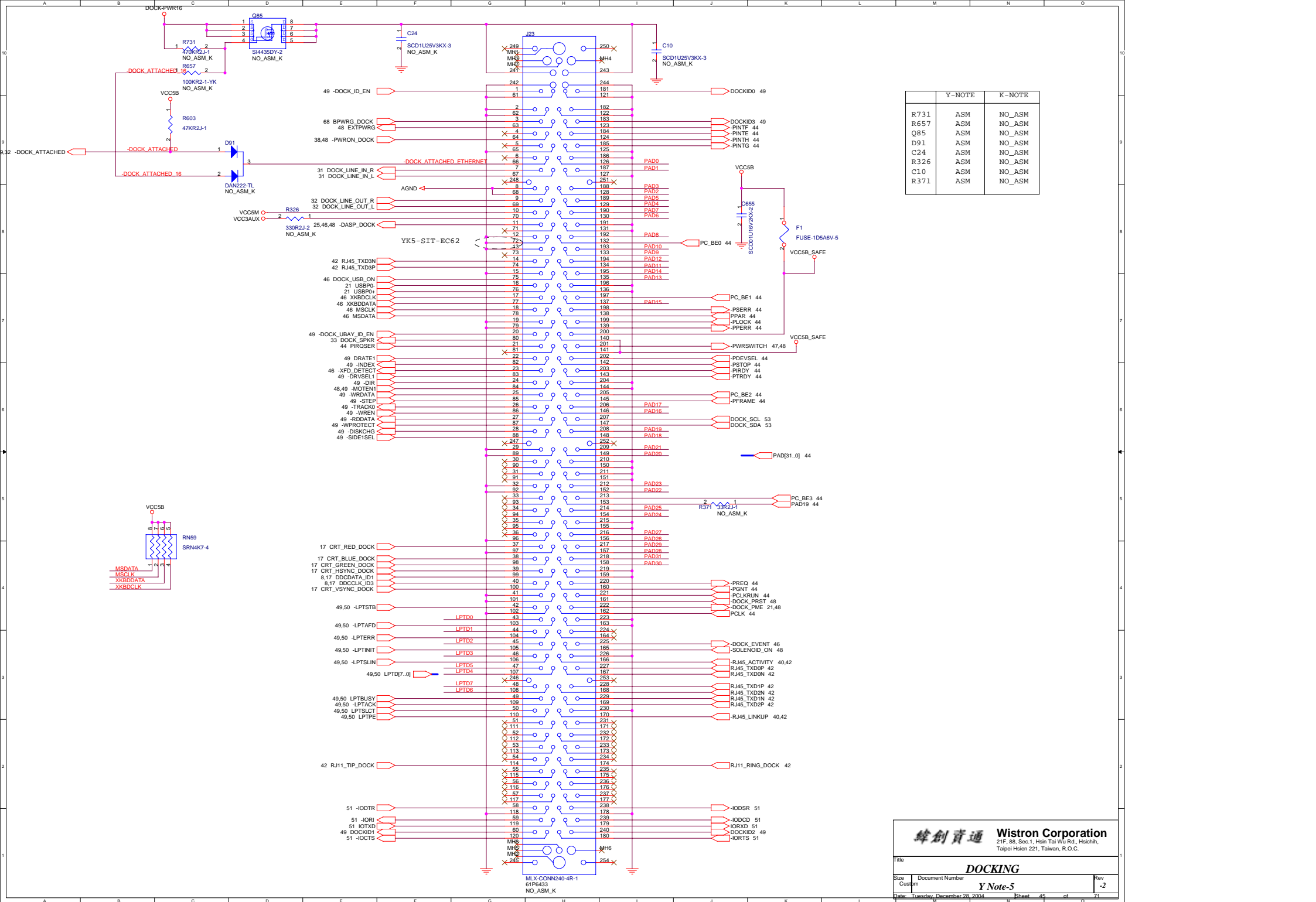

	Y-NOTE	K-NOTE
R731	ASM	NO_ASM
R657	ASM	NO_ASM
Q85	ASM	NO_ASM
D91	ASM	NO_ASM
C24	ASM	NO_ASM
R326	ASM	NO_ASM
C10	ASM	NO_ASM
R371	ASM	NO_ASM

**緯創資通 Wistron Corporation**  
 21F, 88, Sec.1, Hsin Tai Wu Rd., Hsichih,  
 Taipei Hsien 221, Taiwan, R.O.C.

Title: **DOCKING**

Size: Document Number  
 Custom: **Y Note-5**

Date: Tuesday, December 28, 2004 Sheet: 45 of 71

- NEAR H8S/2169A:
- SHORT PATTERN
- NO PATTERN UNDER THIS AREA

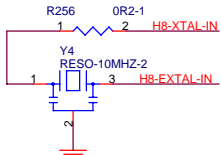

R1069	ASM	K-NOTE	Y-NOTE
R329	NO_ASM	ASM	NO_ASM

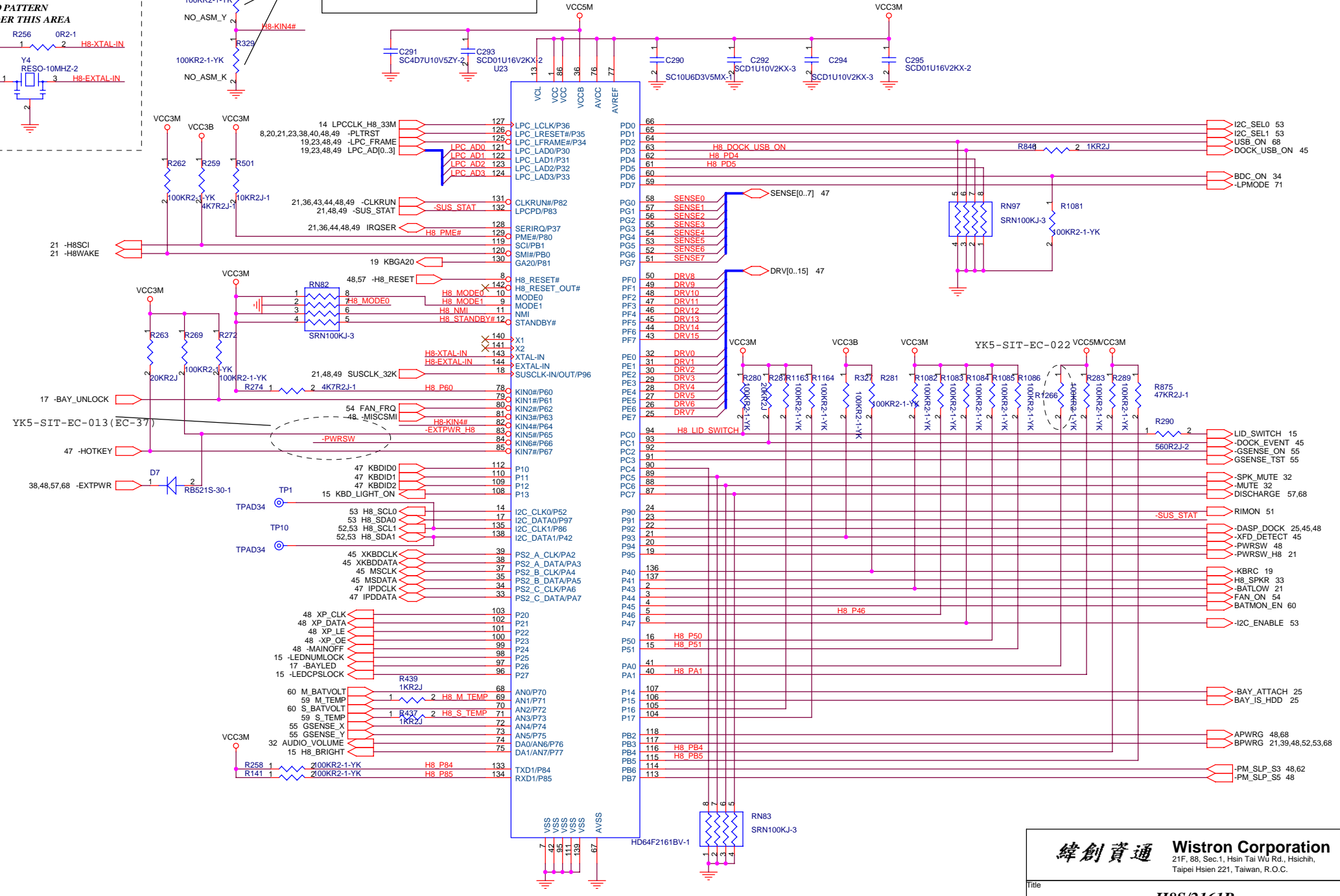

**緯創資通 Wistron Corporation**  
 21F, 88, Sec.1, Hsin Tai Wj Rd., Hsichih, Taipei Hsien 221, Taiwan, R.O.C.

Title: **H8S/2161B**

Size: A3 Document Number: **Y Note-5** Rev: -2

Date: Tuesday, December 28, 2004 Sheet: 46 of 71

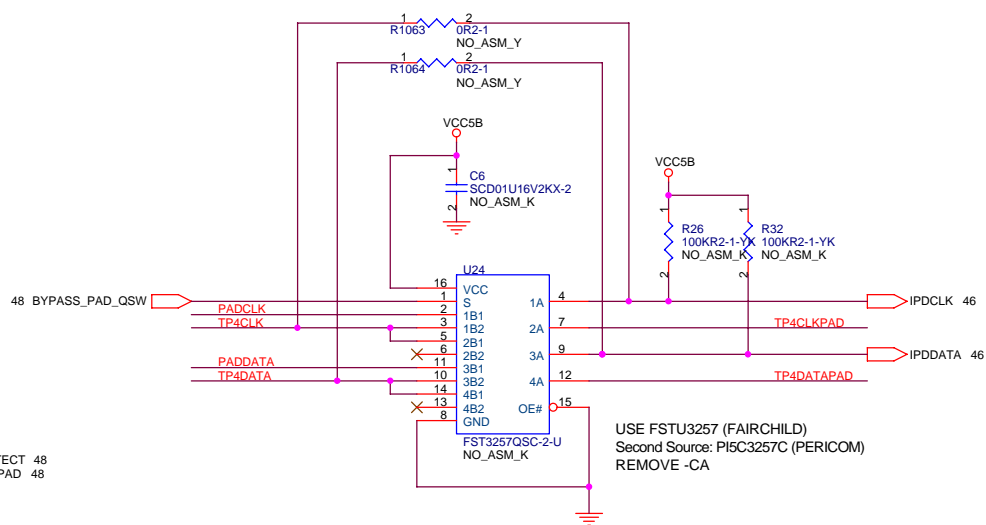
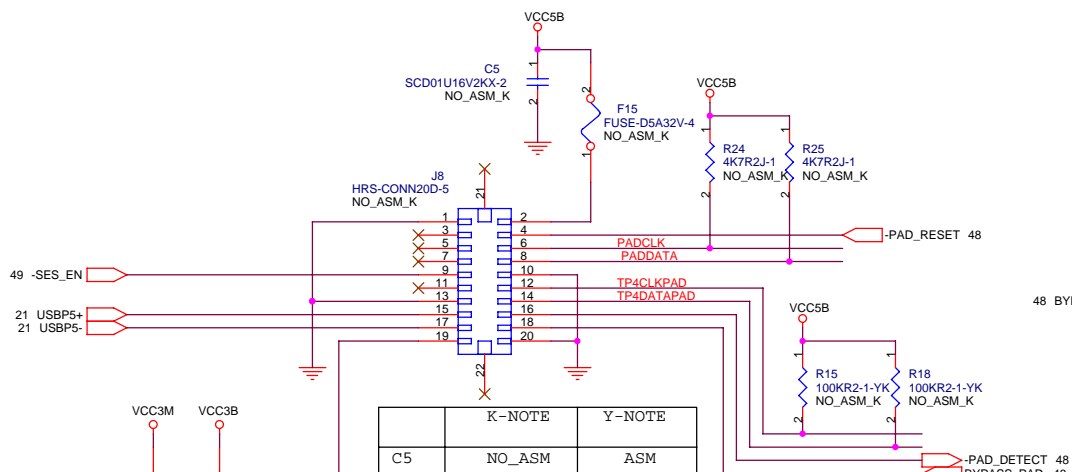
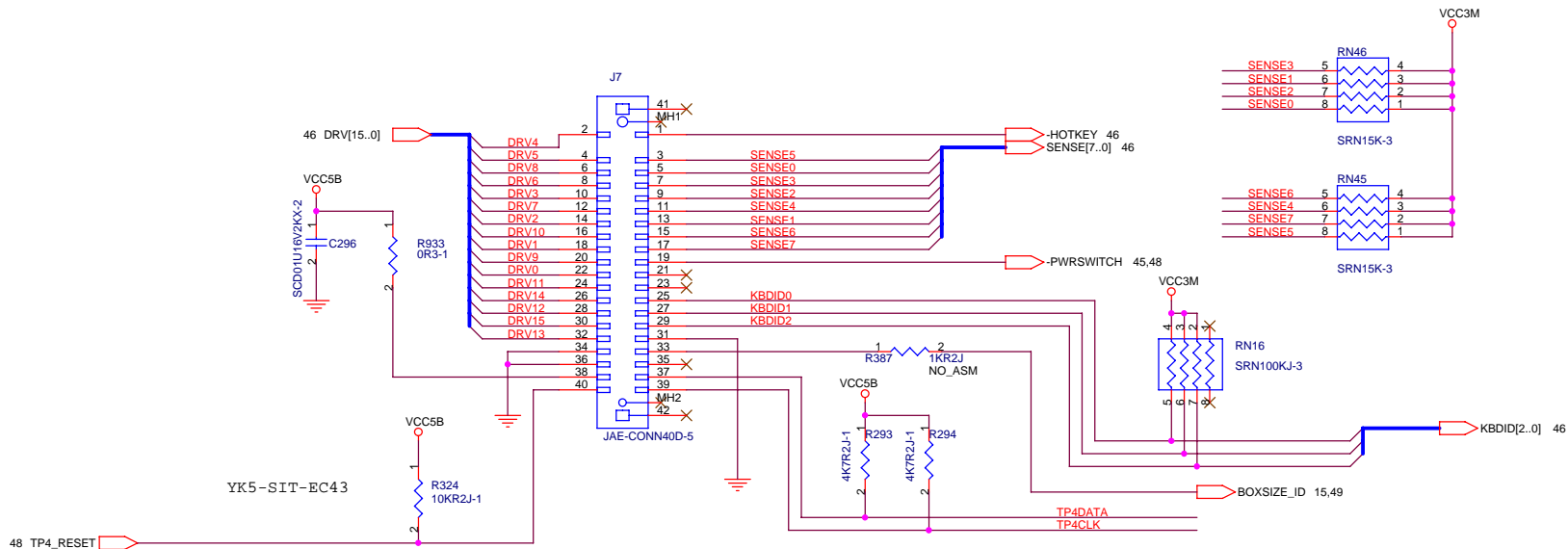

	K-NOTE	Y-NOTE
C5	NO_ASM	ASM
C6	NO_ASM	ASM
F15	NO_ASM	ASM
J8	NO_ASM	ASM
R15	NO_ASM	ASM
R18	NO_ASM	ASM
R24	NO_ASM	ASM
R25	NO_ASM	ASM
R1063	ASM	NO_ASM
R1064	ASM	NO_ASM
R26	NO_ASM	ASM
R32	NO_ASM	ASM
R387	NO_ASM	NO_ASM
U24	NO_ASM	ASM
F6	NO_ASM	ASM
C208	NO_ASM	ASM

**緯創資通 Wistron Corporation**  
 21F, 88, Sec.1, Hsin Tai Wj Rd., Hsichih,  
 Taipei Hsien 221, Taiwan, R.O.C.

Title: **KEYBOARD & TOUCHPAD**

Size: A3 Document Number: **Y Note-5** Rev: -2

Date: Tuesday, December 28, 2004 Sheet: 47 of 71

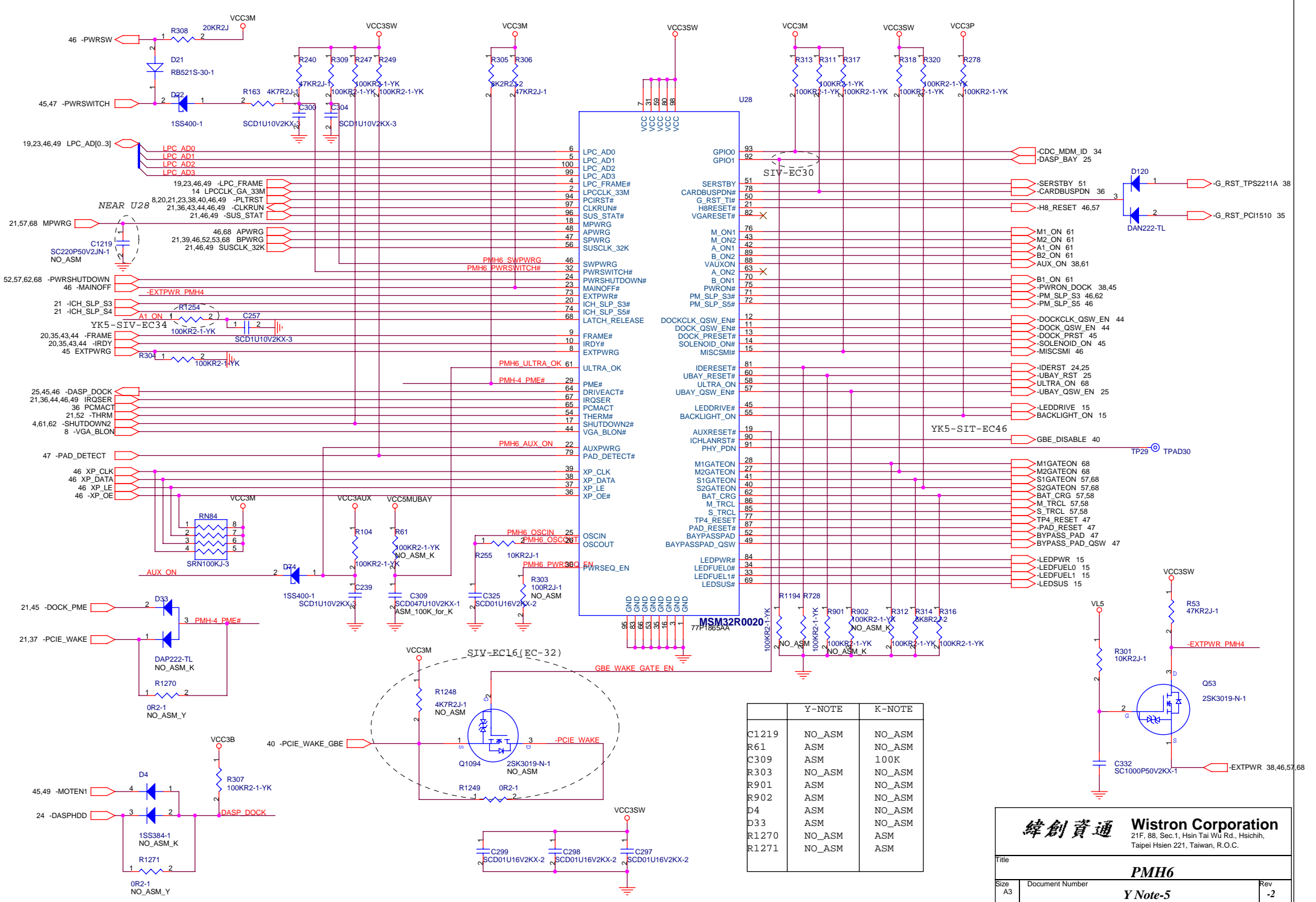

	Y-NOTE	K-NOTE
C1219	NO_ASM	NO_ASM
R61	ASM	NO_ASM
C309	ASM	100K
R303	NO_ASM	NO_ASM
R901	ASM	NO_ASM
R902	ASM	NO_ASM
D4	ASM	NO_ASM
D33	ASM	NO_ASM
R1270	NO_ASM	ASM
R1271	NO_ASM	ASM

**緯創資通 Wistron Corporation**  
21F, 88, Sec.1, Hsin Tai Wu Rd., Hsichih,  
Taipei Hsien 221, Taiwan, R.O.C.

---

**PMH6**

Title	<b>PMH6</b>	Rev
Size	Document Number	-2
<b>Y Note-5</b>		
Date:	Tuesday, December 28, 2004	Sheet 48 of 71





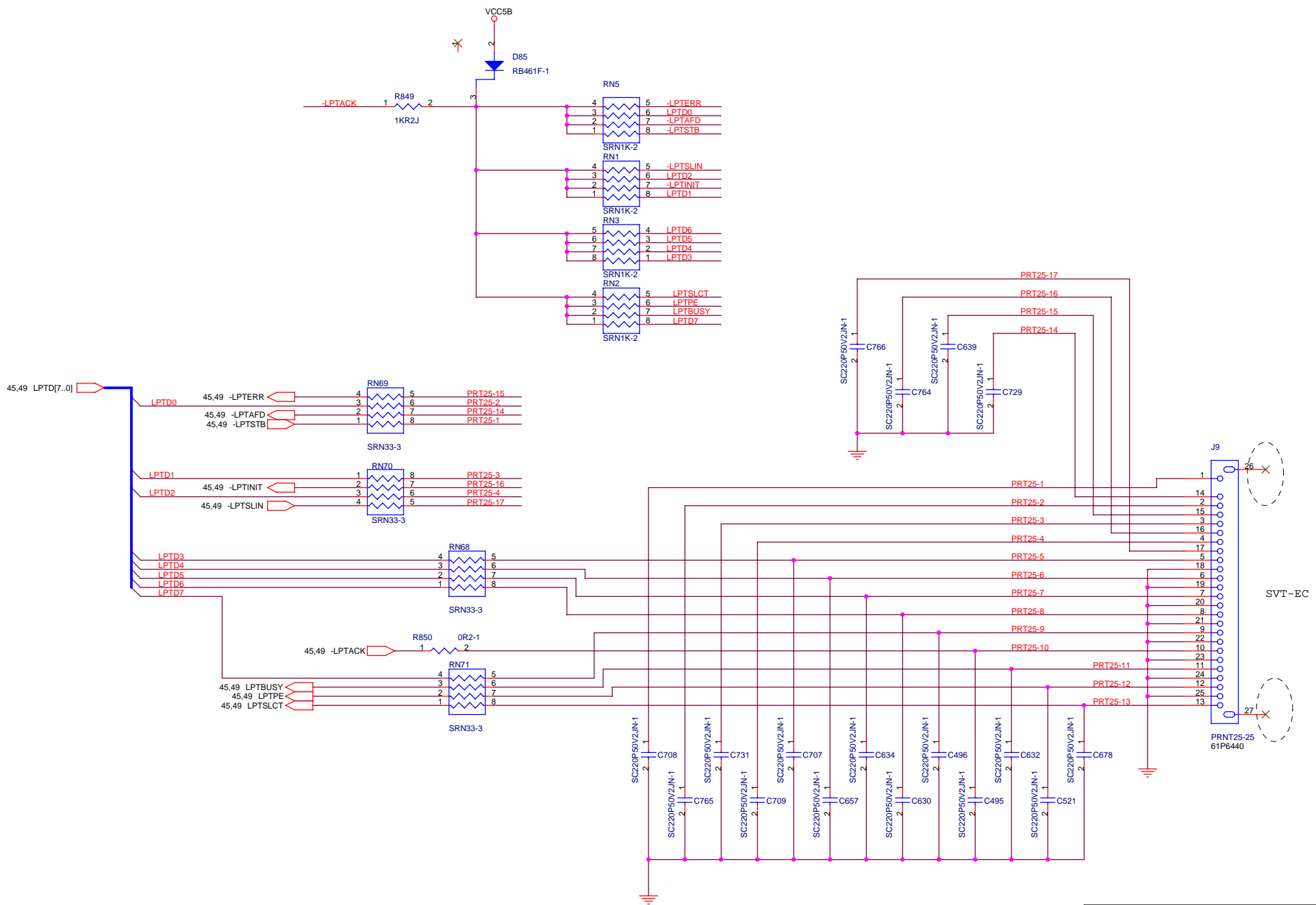

**緯創資通 Wistron Corporation**  
 21F, 88, Sec.1, Hsin Tai WJ Rd., Hsichih,  
 Taipei Hsien 221, Taiwan, R.O.C.

Title		
<b>PARALLEL</b>		
Size	Document Number	Rev
A3	<b>Y Note-5</b>	-2
Date: Tuesday, December 28, 2004		
Sheet		of
50		71

	Y-NOTE	K-NOTE
R337	ASM	NO_ASM
C361	ASM	NO_ASM
R340	ASM	NO_ASM
U54	ASM	NO_ASM
R826	ASM	NO_ASM
R827	NO_ASM	NO_ASM
C666	NO_ASM	NO_ASM
C633	ASM	NO_ASM
R843	ASM	NO_ASM
R847	ASM	NO_ASM
U36	ASM	NO_ASM
C357	ASM	NO_ASM
C358	ASM	NO_ASM
C363	ASM	NO_ASM
C380	ASM	NO_ASM

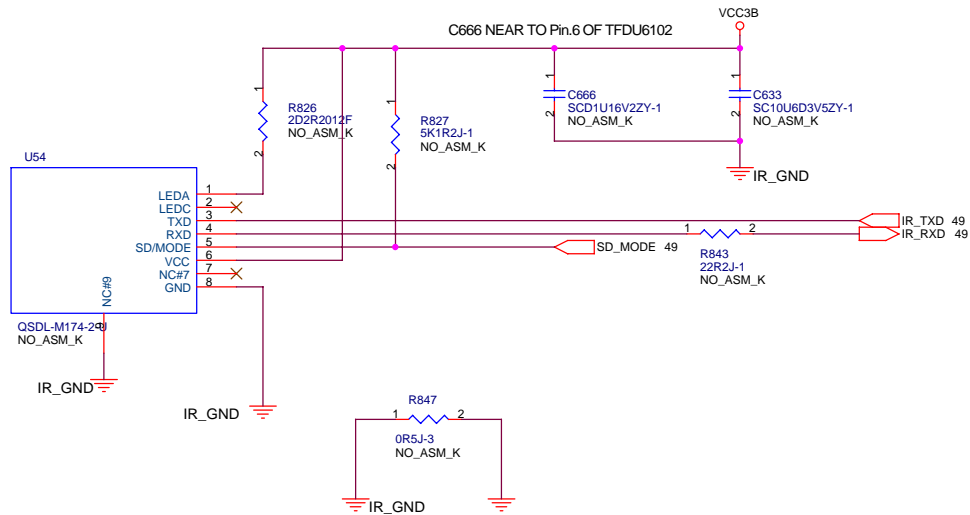
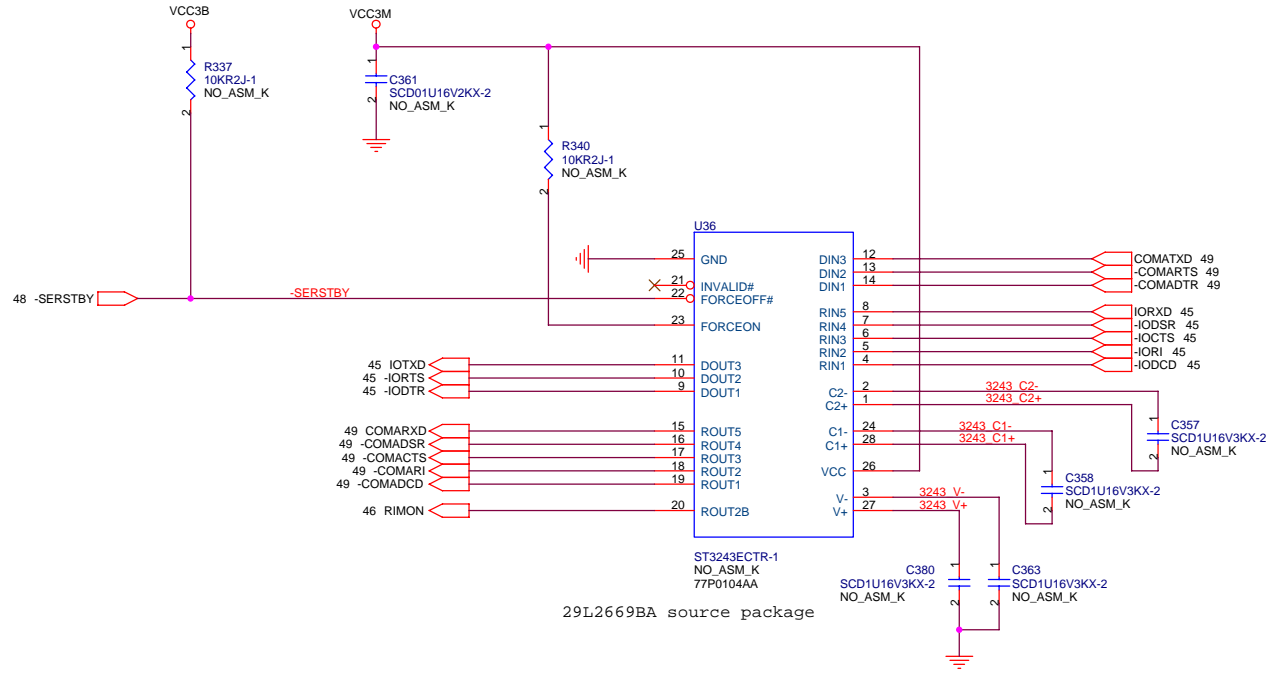

<b>緯創資通</b>		<b>Wistron Corporation</b>	
		21F, 88, Sec.1, Hsin Tai WJ Rd., Hsichih, Taipei Hsien 221, Taiwan, R.O.C.	
Title			
<b>SERIAL I/F &amp; IR MODULE</b>			
Size	Document Number	Rev	
A3		<b>Y Note-5</b>	
Date: Tuesday, December 28, 2004		Sheet	71



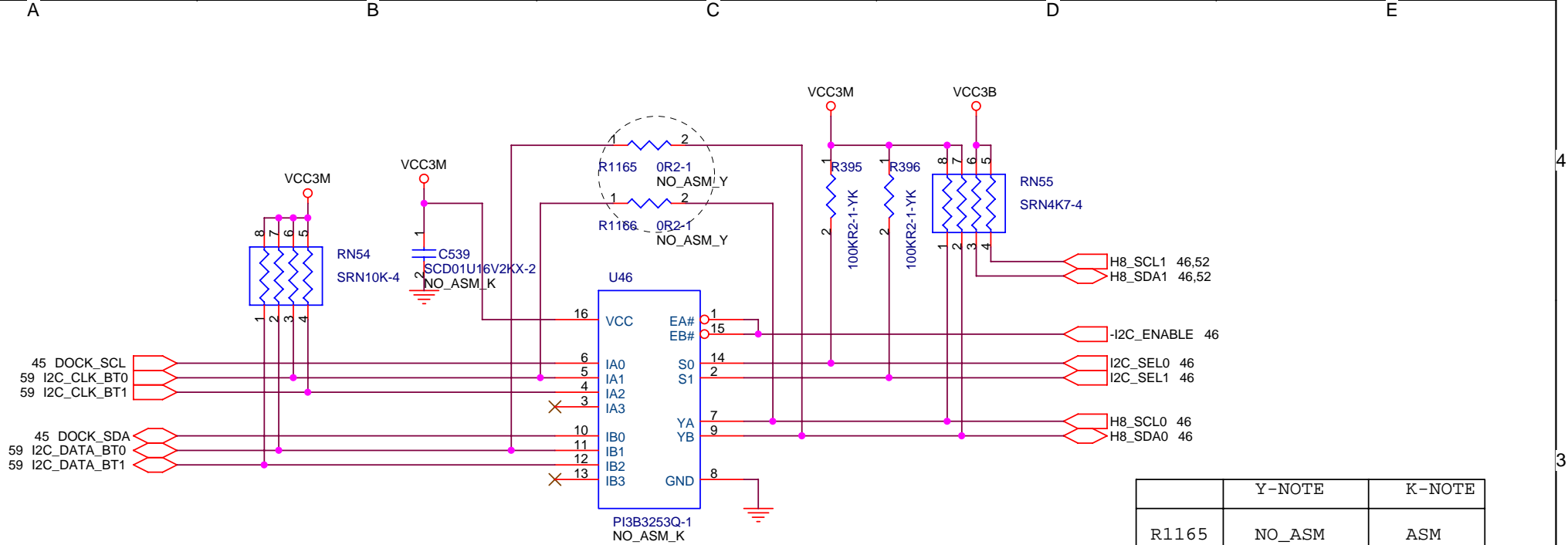

	Y-NOTE	K-NOTE
R1165	NO_ASM	ASM
R1166	NO_ASM	ASM
C539	ASM	NO_ASM
U46	ASM	NO_ASM

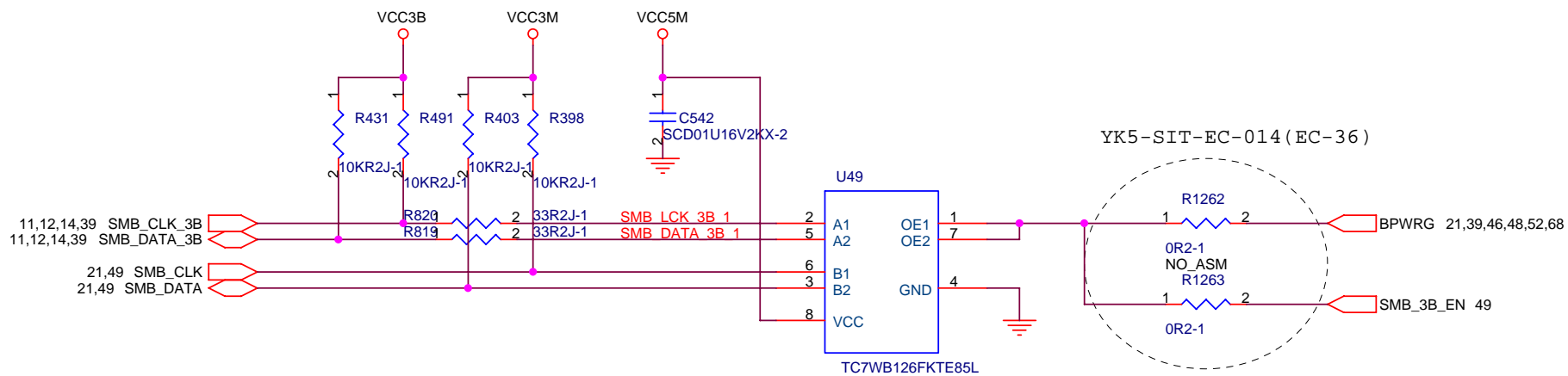

**緯創資通** **Wistron Corporation**  
 21F, 88, Sec.1, Hsin Tai Wu Rd., Hsichih,  
 Taipei Hsien 221, Taiwan, R.O.C.

Title: **I2CBUS/SMBUS**

Size A4	Document Number <b>Y Note-5</b>	Rev -2
------------	------------------------------------	-----------

Date: Tuesday, December 28, 2004      Sheet 53 of 71

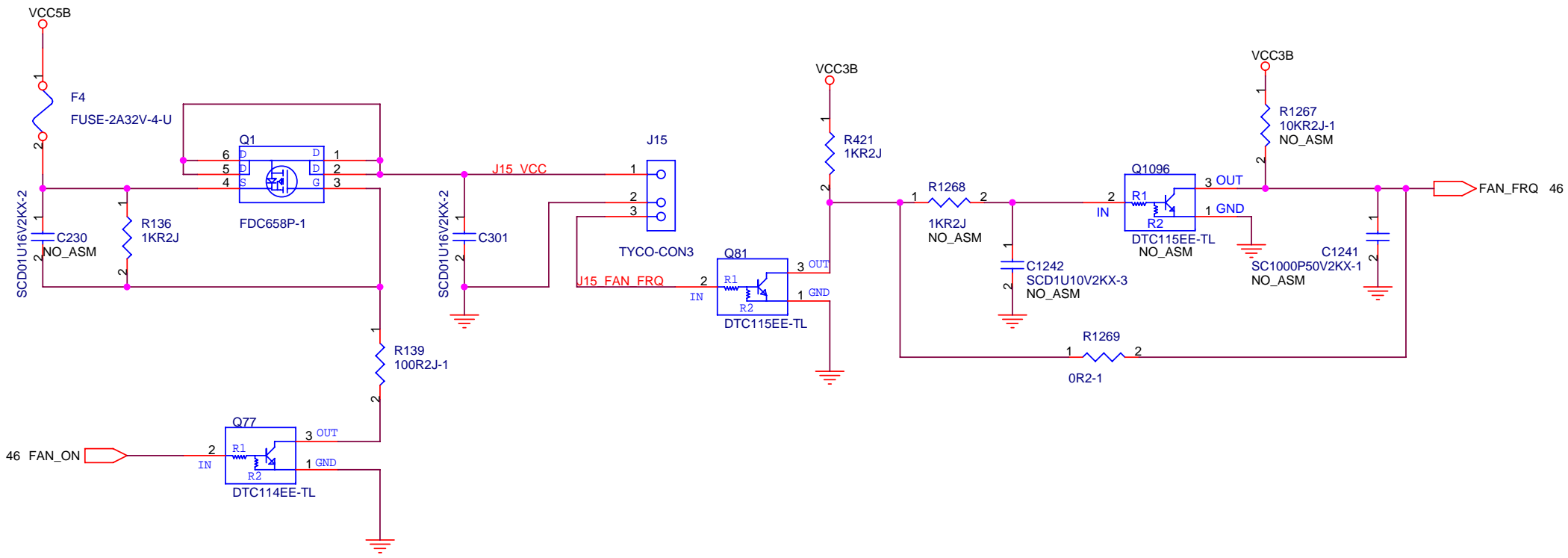

	Y-NOTE	K-NOTE
C230	NO_ASM	NO_ASM

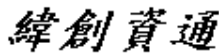
 <b>Wistron Corporation</b> 21F, 88, Sec.1, Hsin Tai Wu Rd., Hsichih, Taipei Hsien 221, Taiwan, R.O.C.	
<b>FAN CONTROL</b>	
Title Size A4	Document Number <b>Y Note-5</b>
Date: Tuesday, December 28, 2004	Sheet 54 of 71
	Rev <b>-2</b>

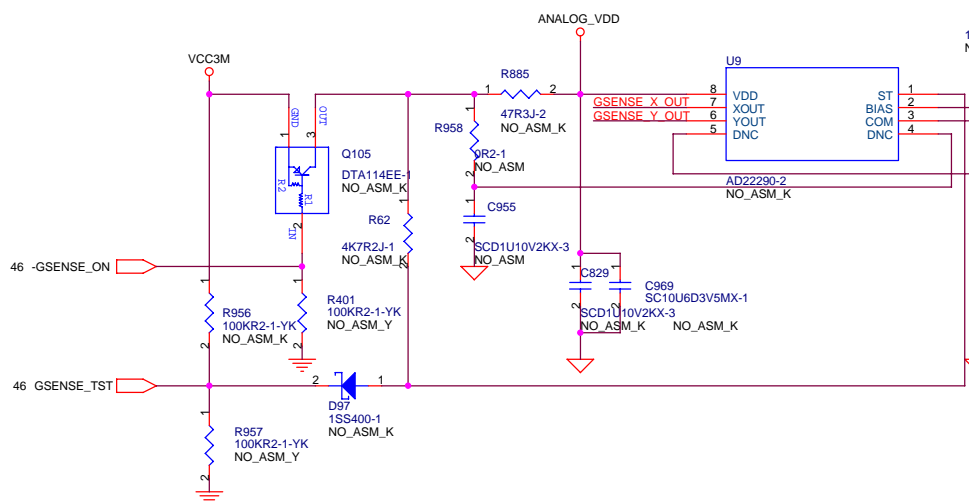

DEFAULT:AD22290

	ADI	MEMSIC	NO ACC.
R401	NO-ASM	NO-ASM	ASM
R957	NO-ASM	ASM	ASM
U9	AD22290	MXA2500	NO-ASM
U13	ASM	NO-ASM	NO-ASM
U39	ASM	NO-ASM	NO-ASM
Q105	ASM	ASM	NO-ASM
D97	ASM	NO-ASM	NO-ASM
R956	ASM	NO-ASM	NO-ASM
R62	ASM	NO-ASM	NO-ASM
R885	47-OHM	10-OHM	NO-ASM
C829	ASM	ASM	NO-ASM
C969	ASM	NO-ASM	NO-ASM
R914	ASM	NO-ASM	NO-ASM
R959	ASM	ASM	NO-ASM
C830	ASM	NO-ASM	NO-ASM
C847	ASM	NO-ASM	NO-ASM
R960	ASM	NO-ASM	NO-ASM
R961	ASM	NO-ASM	NO-ASM
R963	ASM	NO-ASM	NO-ASM
R565	ASM	NO-ASM	NO-ASM
R964	ASM	NO-ASM	NO-ASM
R965	ASM	NO-ASM	NO-ASM
R966	ASM	NO-ASM	NO-ASM
R465	ASM	NO-ASM	NO-ASM
R969	56K	8.2K	NO-ASM
C938	ASM	ASM	100K
R970	56K	8.2K	NO-ASM
C956	ASM	ASM	NO-ASM
R958	NO-ASM	ASM	NO-ASM
C955	NO-ASM	ASM	NO-ASM
R962	NO-ASM	ASM	NO-ASM
R967	NO-ASM	ASM	NO-ASM
R968	NO-ASM	ASM	NO-ASM
C965	ASM	ASM	100K

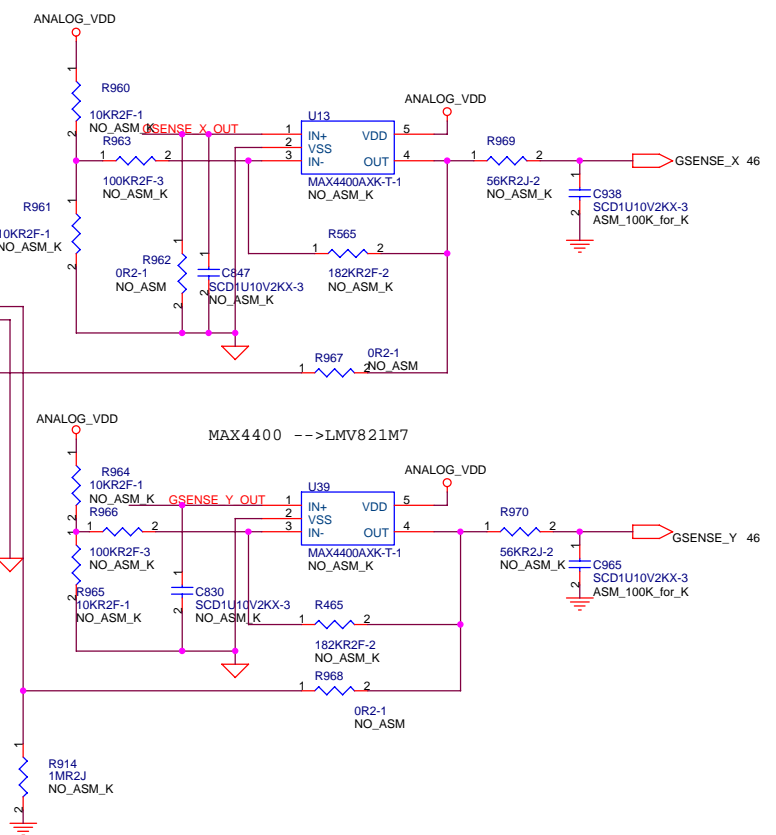
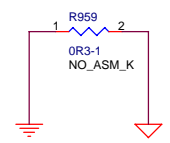

<b>緯創資通</b>		<b>Wistron Corporation</b>	
		21F, 8B, Sec.1, Hsin Tai Wu Rd., Hsichih, Taipei Hsien 221, Taiwan, R.O.C.	
Title <b>G-SENSOR</b>			
Size A3	Document Number	<b>Y Note-5</b>	
		Rev	-2
Date: Tuesday, December 28, 2004		Sheet	55 of 71

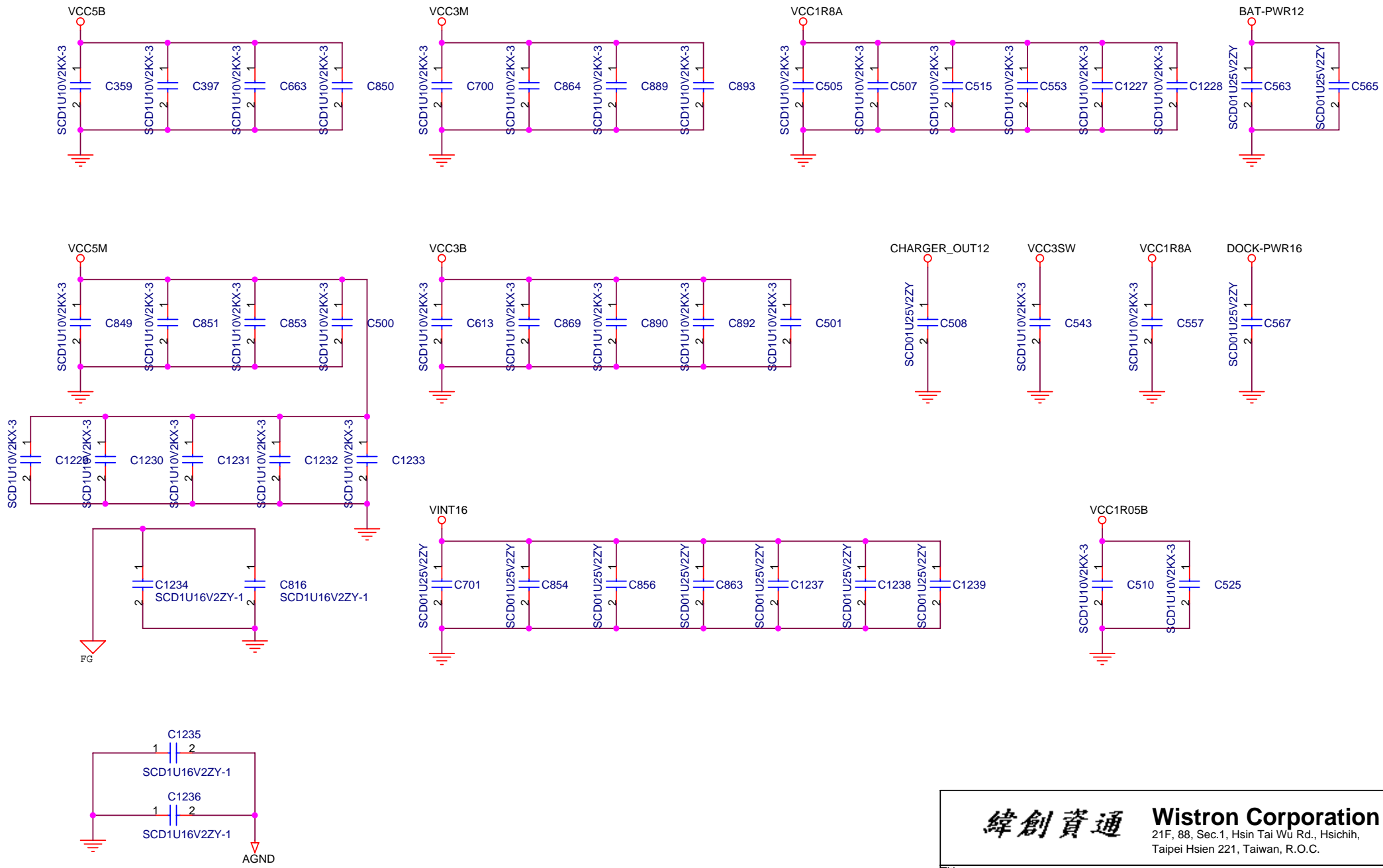

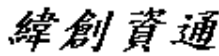
 <b>Wistron Corporation</b> 21F, 88, Sec.1, Hsin Tai Wu Rd., Hsichih, Taipei Hsien 221, Taiwan, R.O.C.	
<b>EMC CAP</b>	
Title Size A4	Document Number <b>Y Note-5</b>
Date: Tuesday, December 28, 2004	Sheet 56 of 71
Rev -2	



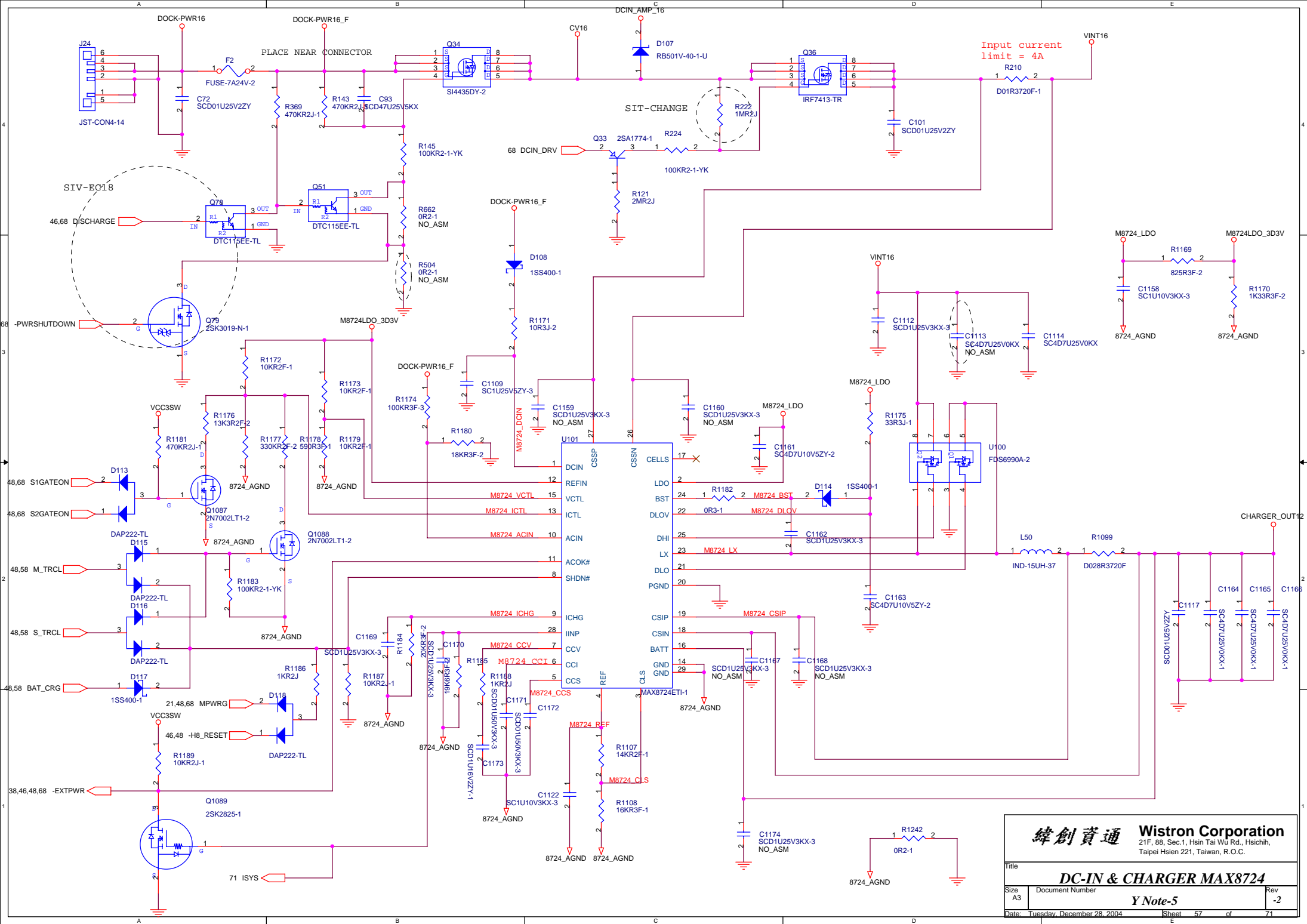

**緯創資通 Wistron Corporation**  
 21F, 88, Sec.1, Hsin Tai WJ Rd., Hsichih,  
 Taipei Hsien 221, Taiwan, R.O.C.

Title		<b>DC-IN &amp; CHARGER MAX8724</b>	
Size	A3	Document Number	<b>Y Note-5</b>
Date: Tuesday, December 28, 2004		Sheet	57 of 71

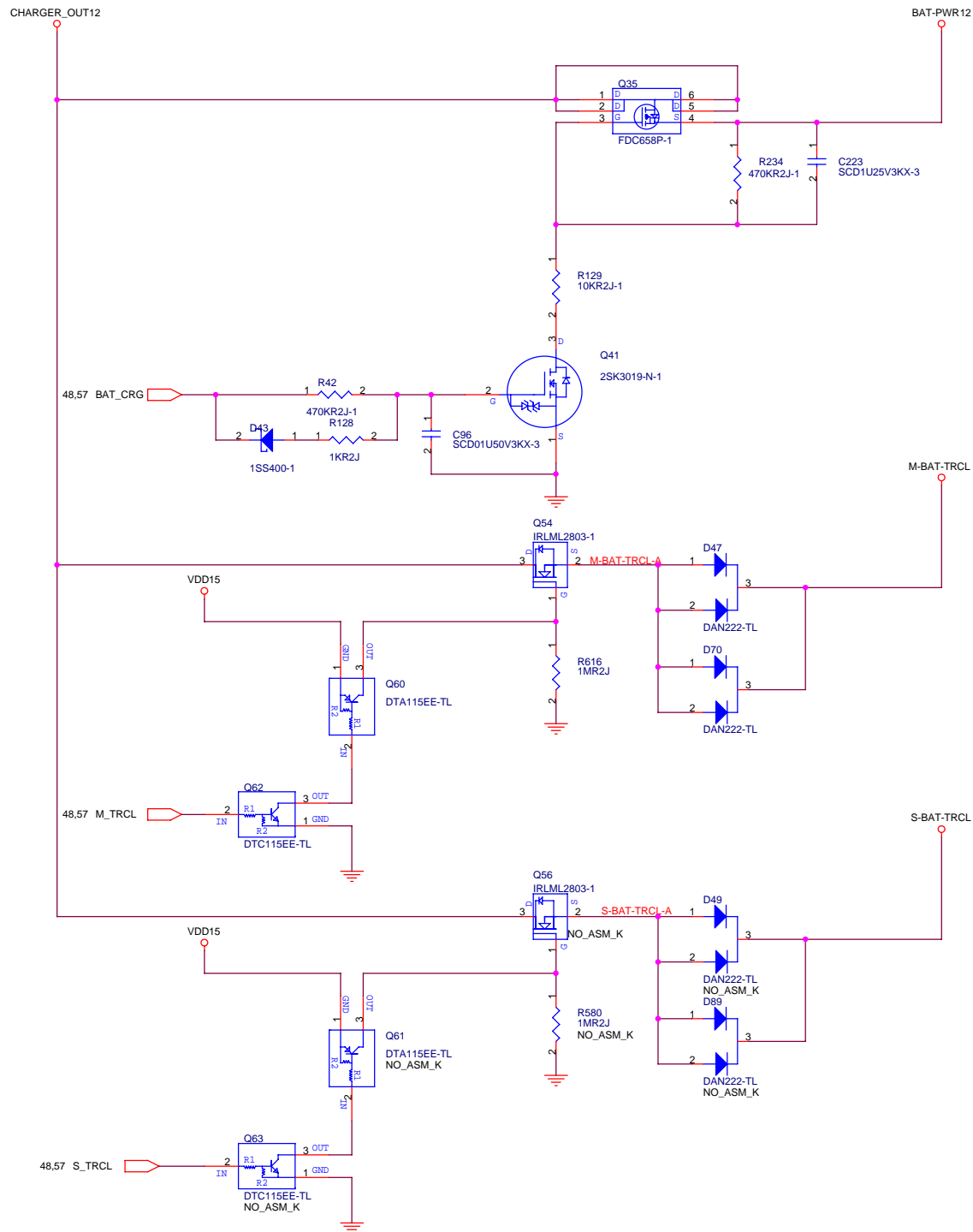

	Y-NOTE	K-NOTE
Q56	ASM	NO_ASM
Q61	ASM	NO_ASM
R580	ASM	NO_ASM
D49	ASM	NO_ASM
D89	ASM	NO_ASM
Q63	ASM	NO_ASM

**緯創資通** **Wistron Corporation**  
 21F, 88, Sec.1, Hsin Tai Wj Rd., Hsichih,  
 Taipei Hsien 221, Taiwan, R.O.C.

<b>CHARGE SELECTOR</b>		
Size A3	Document Number <b>Y Note-5</b>	Rev -2
Date: Tuesday, December 28, 2004		
Sheet 58 of 71		

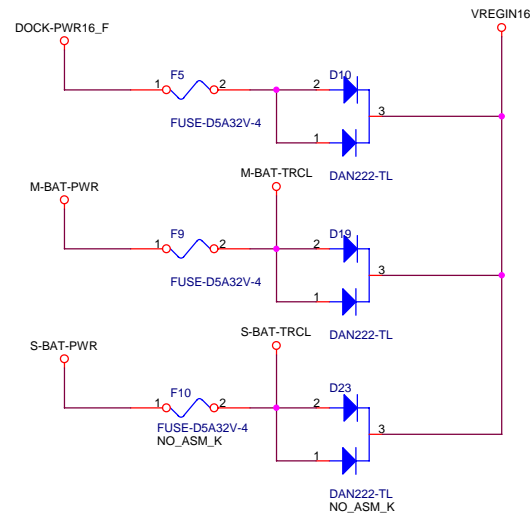
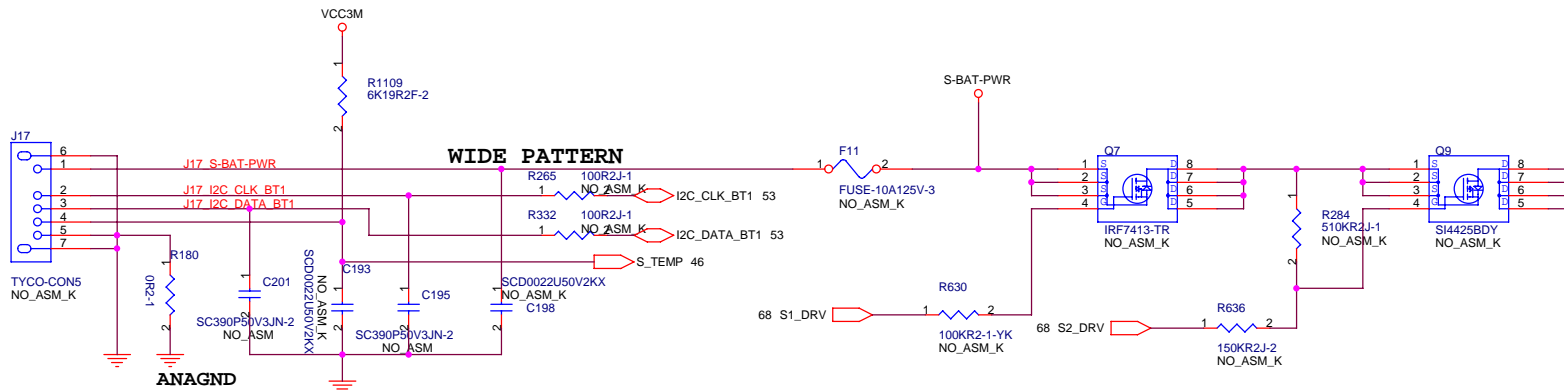
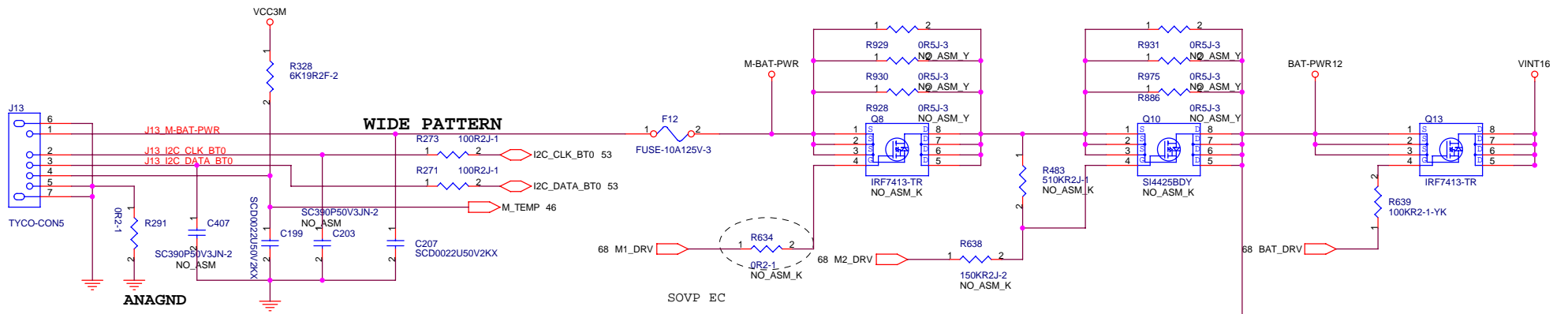

	K-NOTE	Y-NOTE
C193	NO_ASM	ASM
C198	NO_ASM	ASM
F10	NO_ASM	ASM
D23	NO_ASM	ASM
F11	NO_ASM	ASM
Q7	NO_ASM	ASM
Q9	NO_ASM	ASM
R265	NO_ASM	ASM
R284	NO_ASM	ASM
R332	NO_ASM	ASM
R630	NO_ASM	ASM
R636	NO_ASM	ASM
Q8	NO_ASM	ASM
Q10	NO_ASM	ASM
R483	NO_ASM	ASM
R634	NO_ASM	ASM
R638	NO_ASM	ASM
J17	NO_ASM	ASM
R929	ASM	NO_ASM
R930	ASM	NO_ASM
R931	ASM	NO_ASM
R928	ASM	NO_ASM
R886	ASM	NO_ASM
R975	ASM	NO_ASM
C195	NO_ASM	NO_ASM
C201	NO_ASM	NO_ASM
C203	NO_ASM	NO_ASM
C407	NO_ASM	NO_ASM

**緯創資通 Wistron Corporation**  
 21F, 88, Sec.1, Hsin Tai Wj Rd., Hsichih,  
 Taipei Hsien 221, Taiwan, R.O.C.

Title: **BATTERY INPUT**

Size: A3	Document Number: <b>Y Note-5</b>	Rev: -2
----------	----------------------------------	---------

Date: Tuesday, December 28, 2004 Sheet 59 of 71



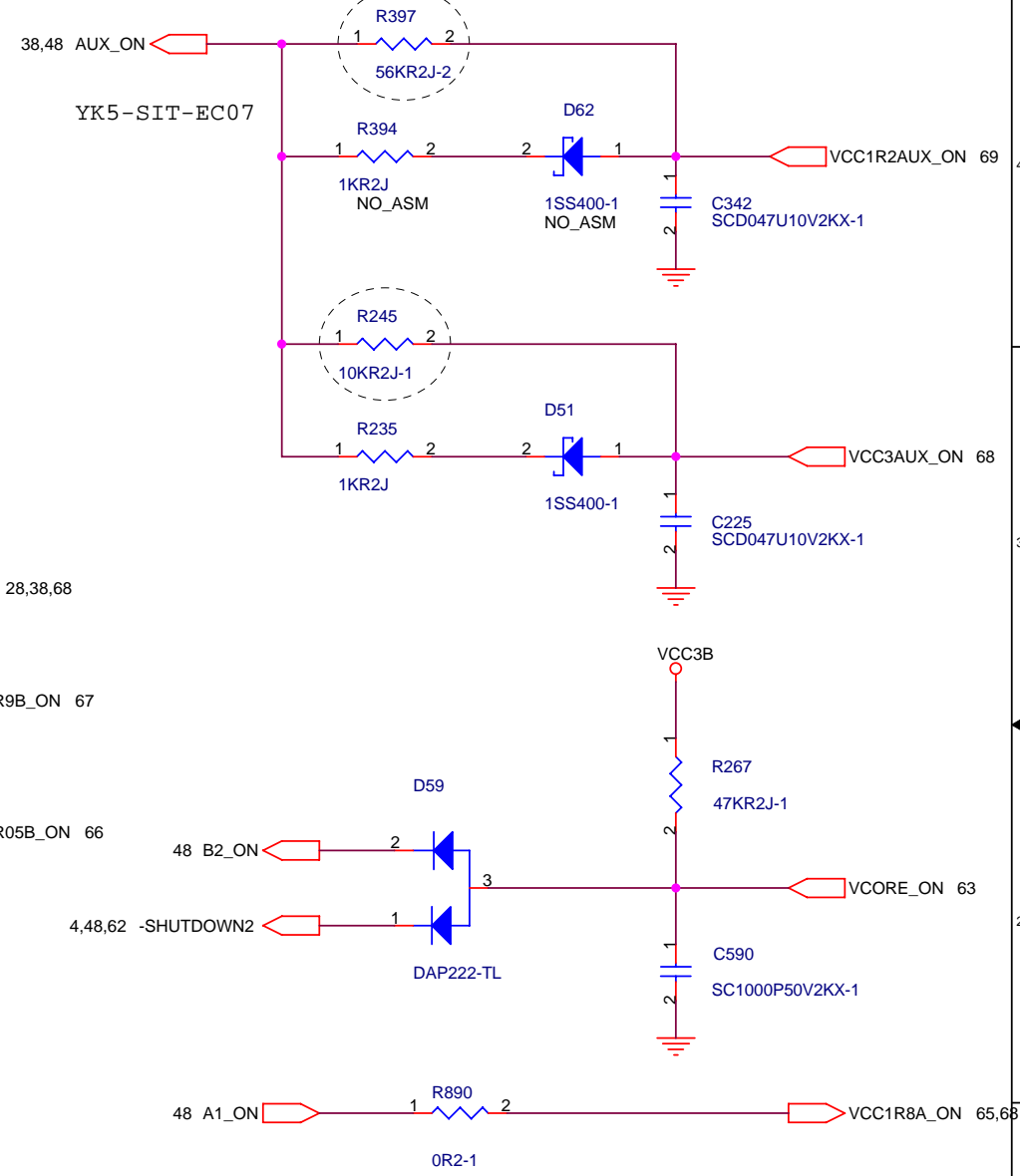
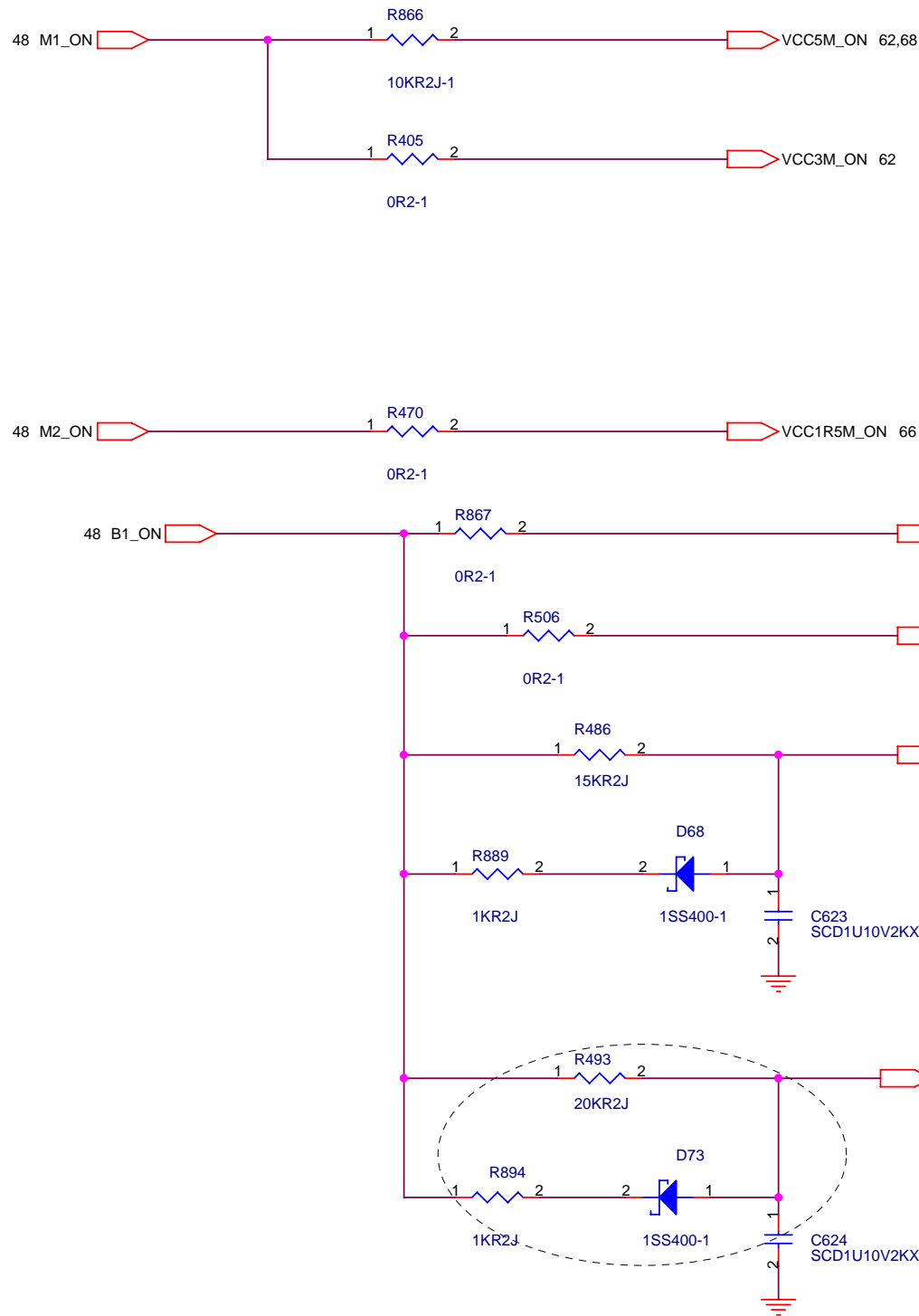

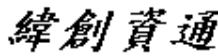
 <b>Wistron Corporation</b> 21F, 88, Sec.1, Hsin Tai Wu Rd., Hsichih, Taipei Hsien 221, Taiwan, R.O.C.	
<b>POWER SEQUENCE</b>	
Size A4	Document Number <b>Y Note-5</b>
Date: Tuesday, December 28, 2004	Rev -2
Sheet 61 of 71	

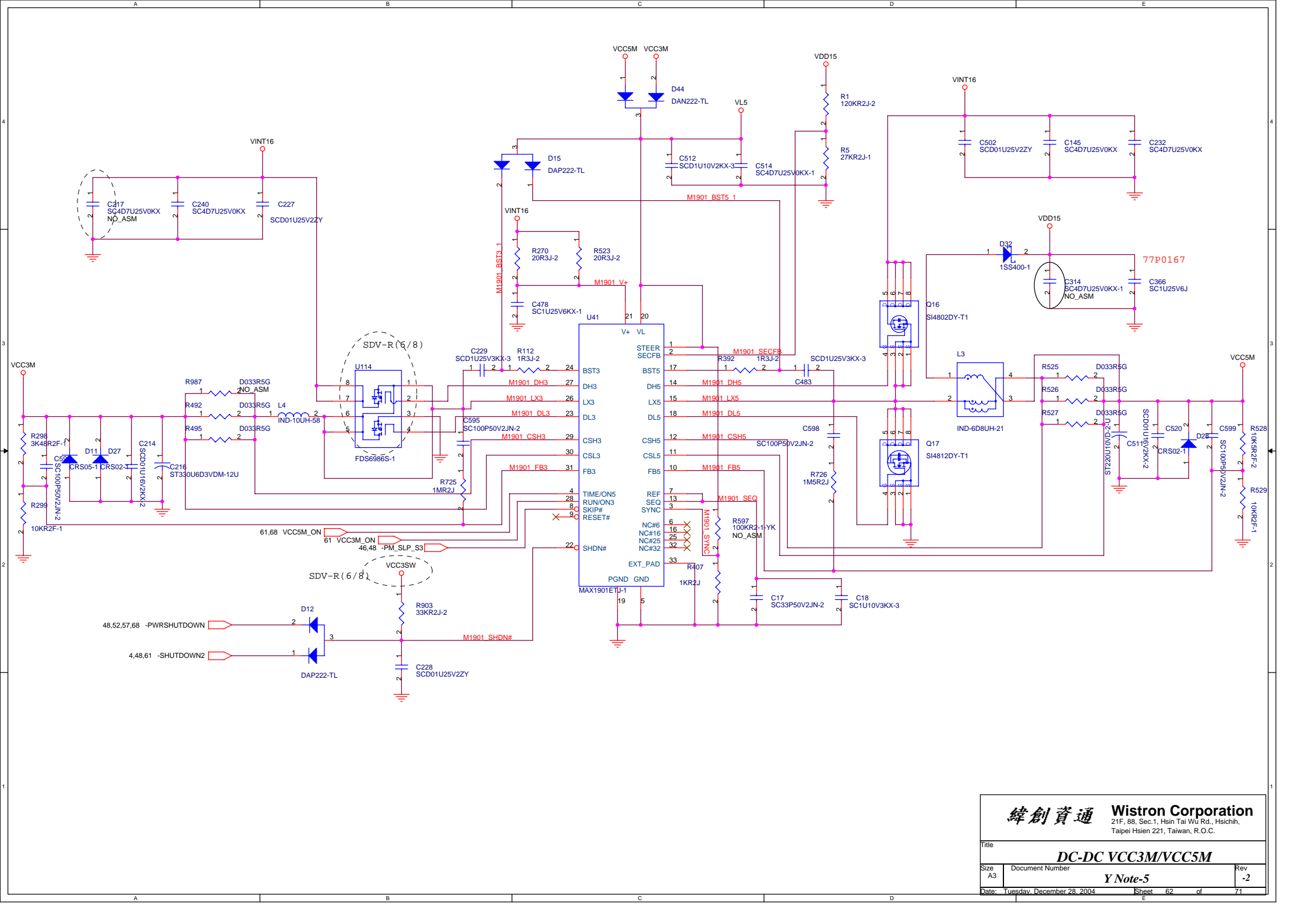

Deep\_Sleep  
 $1.21K/(100K+1.21K)=1.19\%$   
 Offset : 1.2%

Deeper Deep Active  
 DPRSLPVR 1 0 0  
 STP\_CPU# 0 0 1

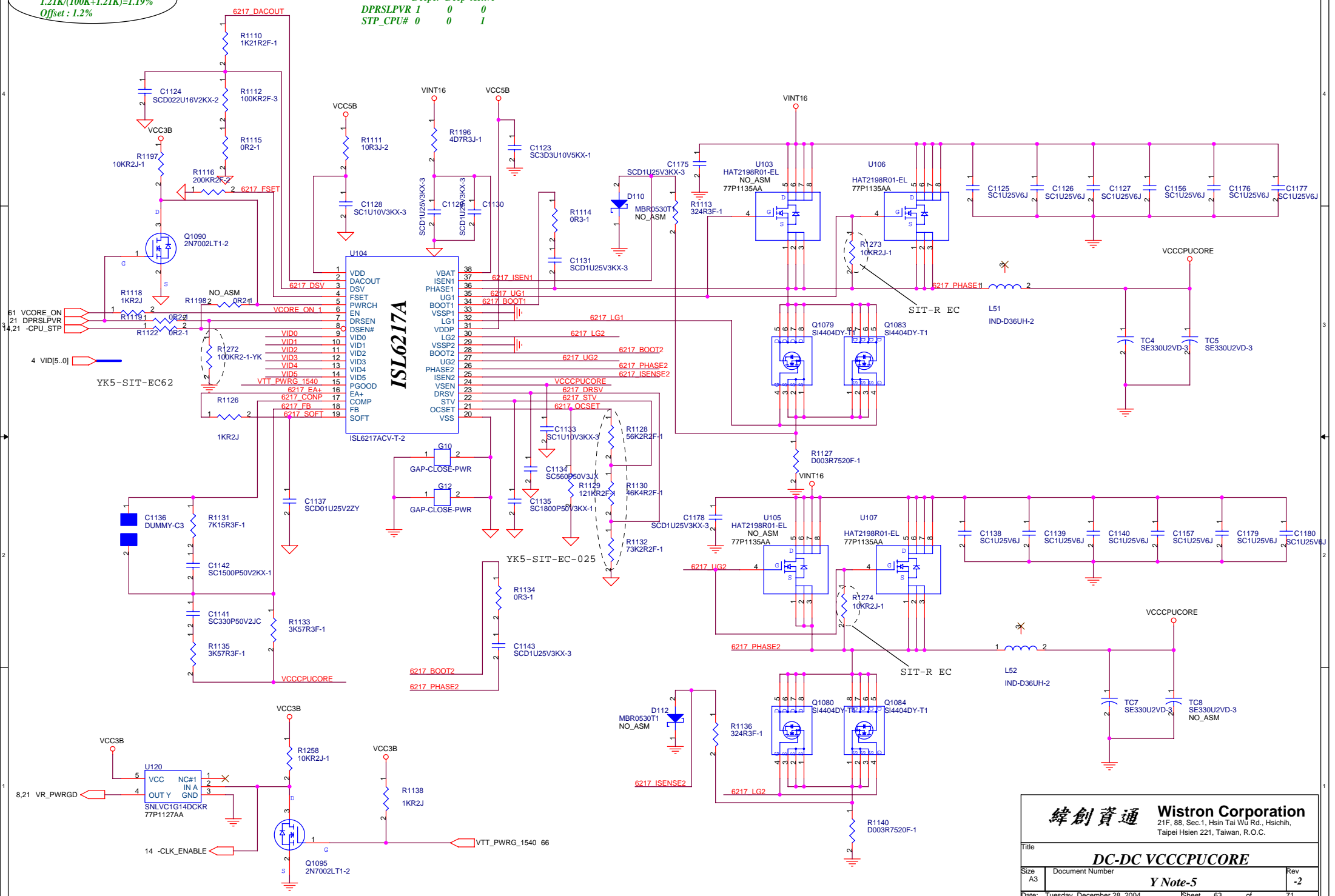

**緯創資通 Wistron Corporation**  
 21F, 88, Sec.1, Hsin Tai Wj Rd., Hsichih,  
 Taipei Hsien 221, Taiwan, R.O.C.

Title		
<b>DC-DC VCCPCUCORE</b>		
Size	Document Number	Rev
A3	<b>Y Note-5</b>	-2
Date: Tuesday, December 28, 2004		Sheet 63 of 71

ALL CAPS ON THIS PAGE ARE NO-ASM FOR VCCCPUCORE.

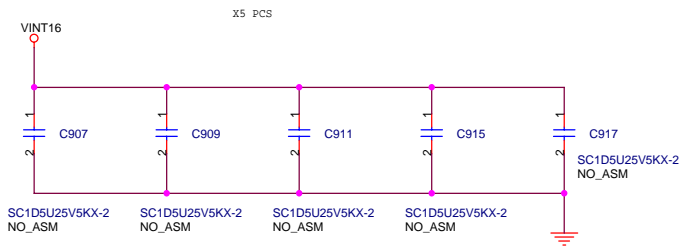
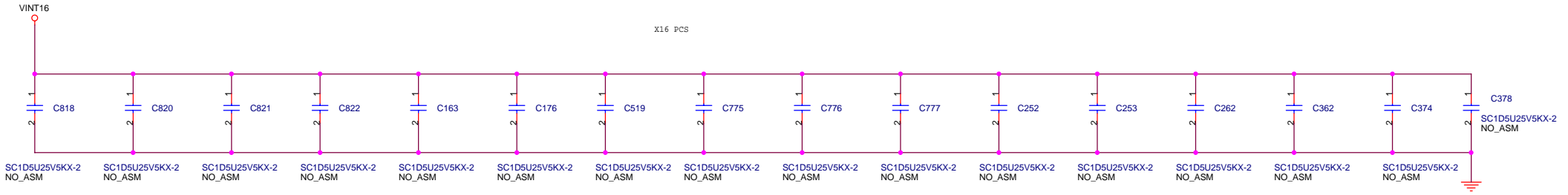
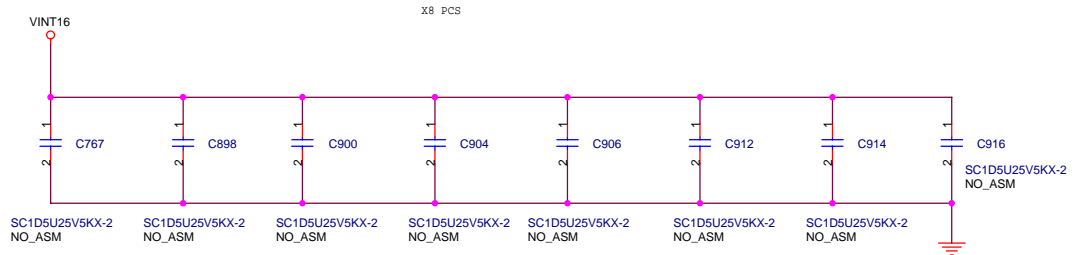

		<b>Wistron Corporation</b> 21F, 88, Sec.1, Hsin Tai WJ Rd., Hsichih, Taipei Hsien 221, Taiwan, R.O.C.	
<b>DC-DC VCCCPUCORE INPUT CAP</b>			
Title		Document Number	
Size	A3	Rev	-2
Date: Tuesday, December 28, 2004		Sheet	64 of 71



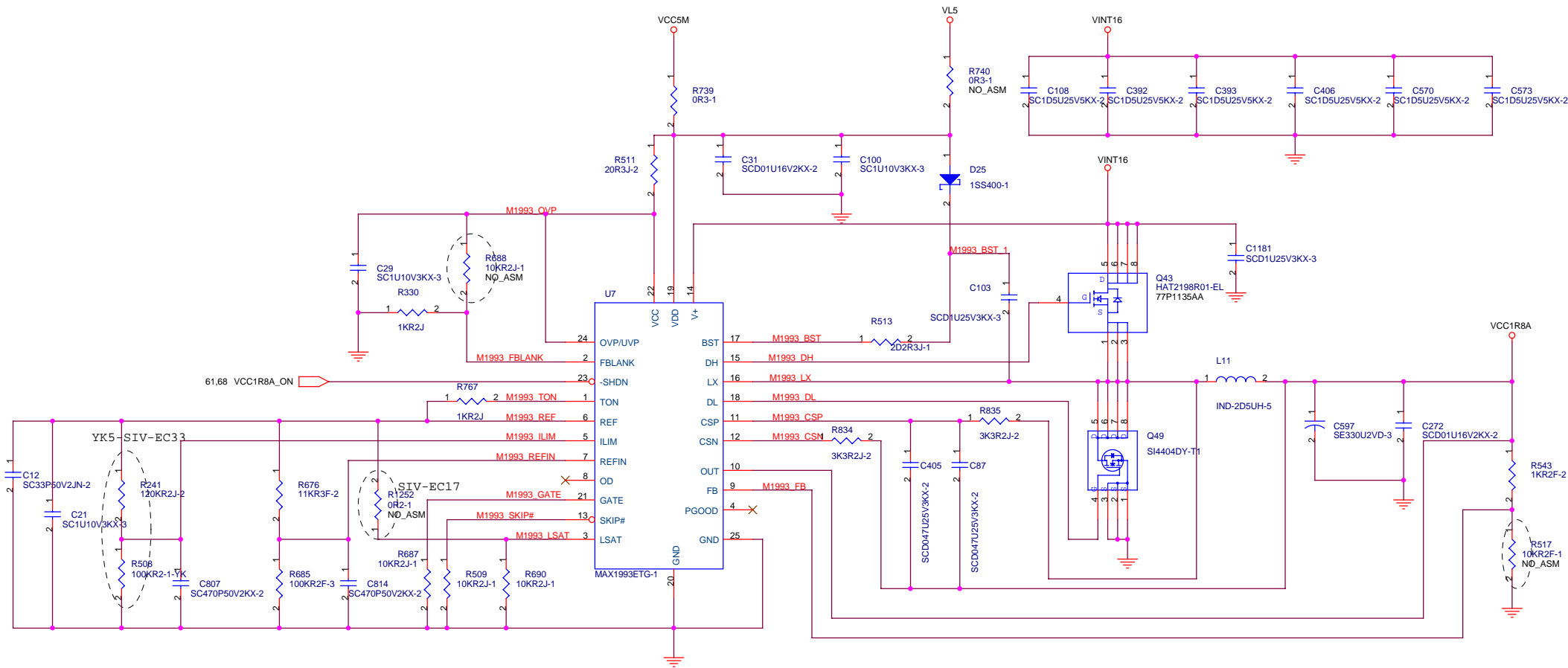

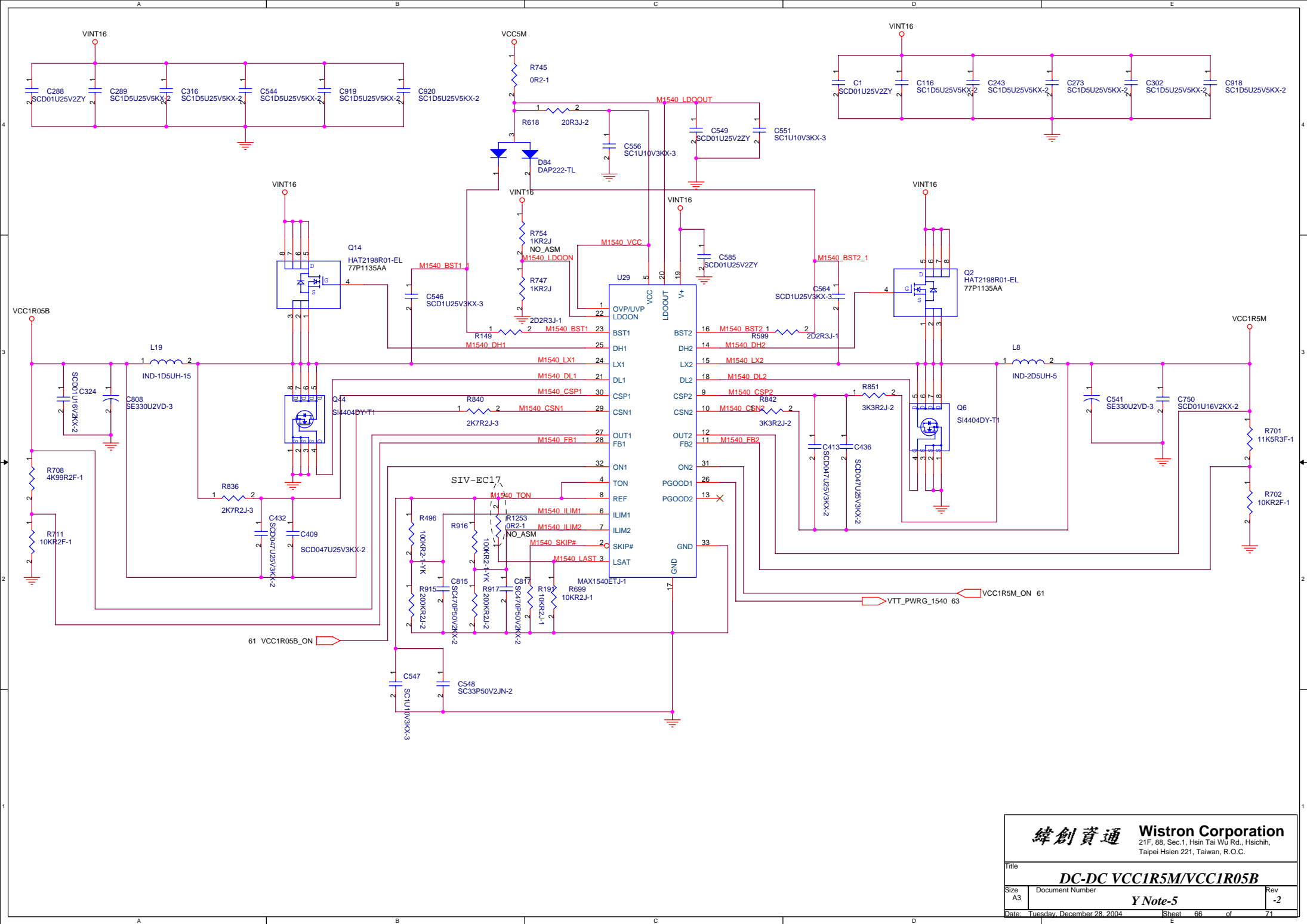

**緯創資通 Wistron Corporation**  
 21F, 88, Sec.1, Hsin Tai WJ Rd., Hsichih,  
 Taipei Hsien 221, Taiwan, R.O.C.

Title		<b>DC-DC VCC1R5M/VCC1R05B</b>	
Size	Document Number		Rev
A3		<b>Y Note-5</b>	-2
Date: Tuesday, December 28, 2004		Sheet	71

	Y-NOTE	K-NOTE
R325	NO_ASM	NO_ASM

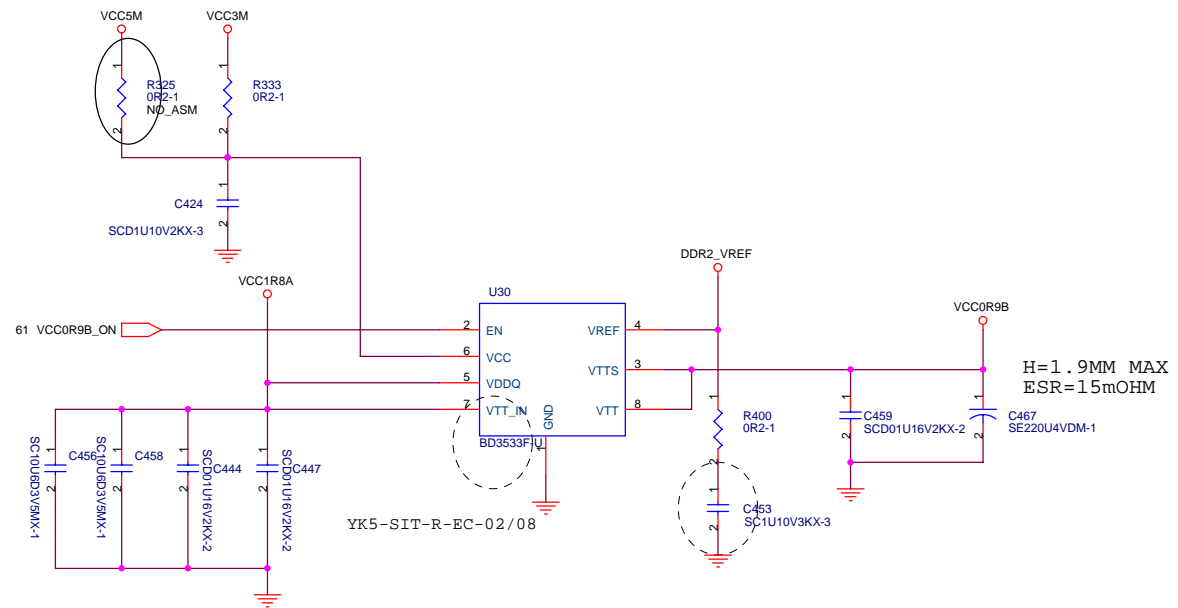
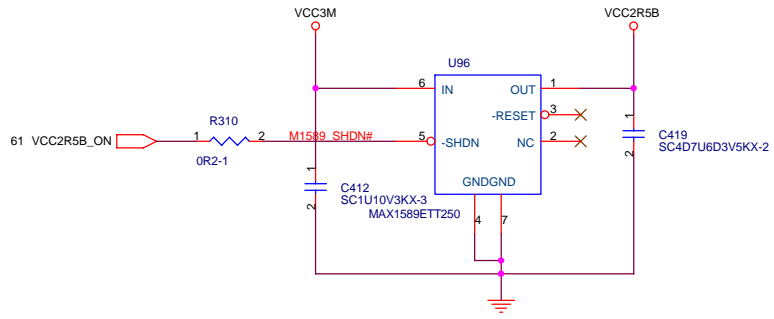

**緯創資通** Wistron Corporation  
 21F, 88, Sec.1, Hsin Tai WJ Rd., Hsichih,  
 Taipei Hsien 221, Taiwan, R.O.C.

Title			DC-DC VCC2R5A/VCC0R9B		
Size			Document Number		
A3	Y Note-5			Rev	
			-2		
Date: Tuesday, December 28, 2004			Sheet 67 of 71		

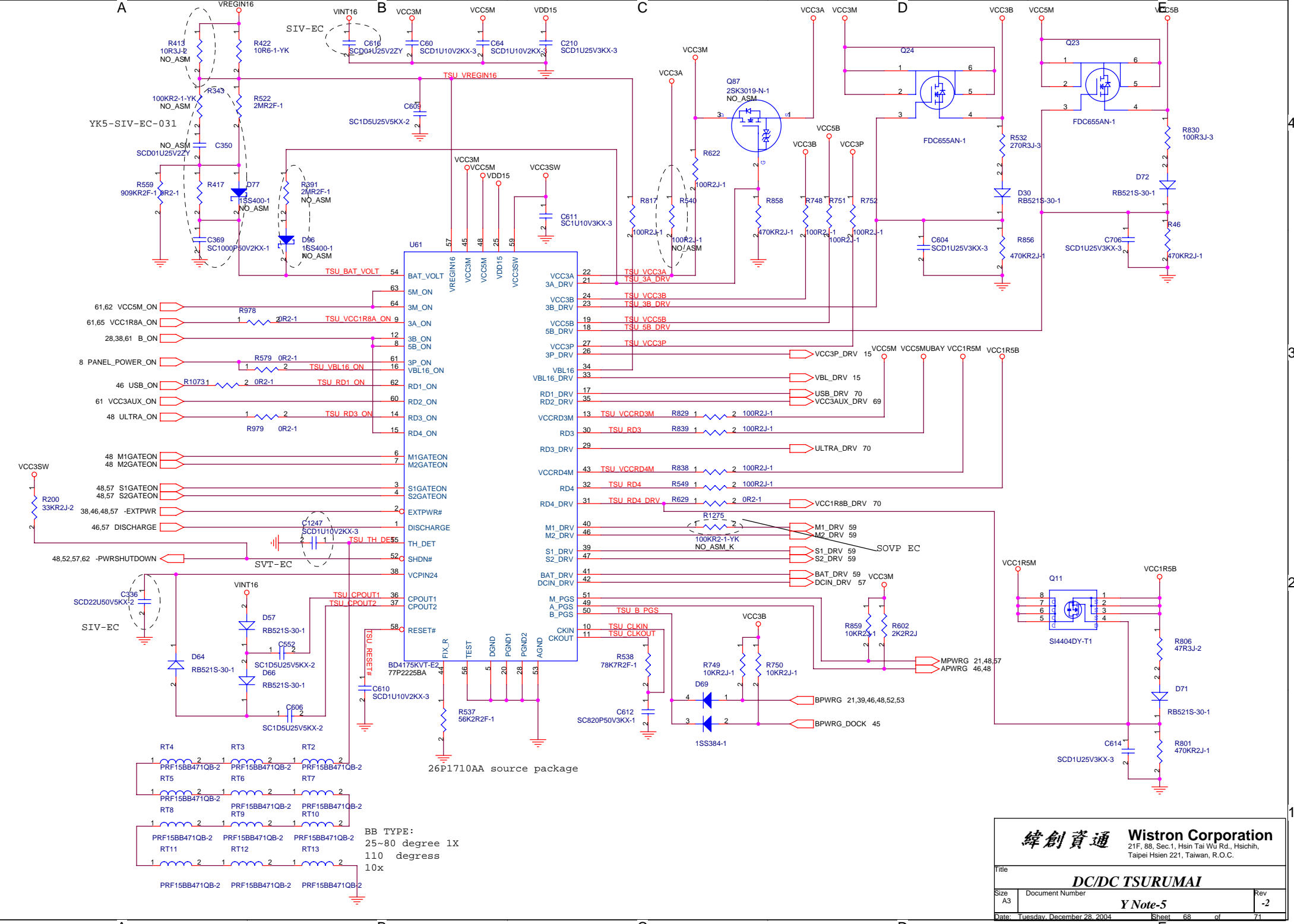



**緯創資通** **Wistron Corporation**  
 21F, 88, Sec.1, Hsin Tai Wu Rd., Hsichih,  
 Taipei Hsien 221, Taiwan, R.O.C.

Title		
<b>DC/DC TSURUMAI</b>		
Size	Document Number	Rev
A3	<b>Y Note-5</b>	-2
Date: Tuesday, December 28, 2004		
Sheet 68		of 71

BB TYPE:  
 25~80 degree 1X  
 110 degress  
 10x

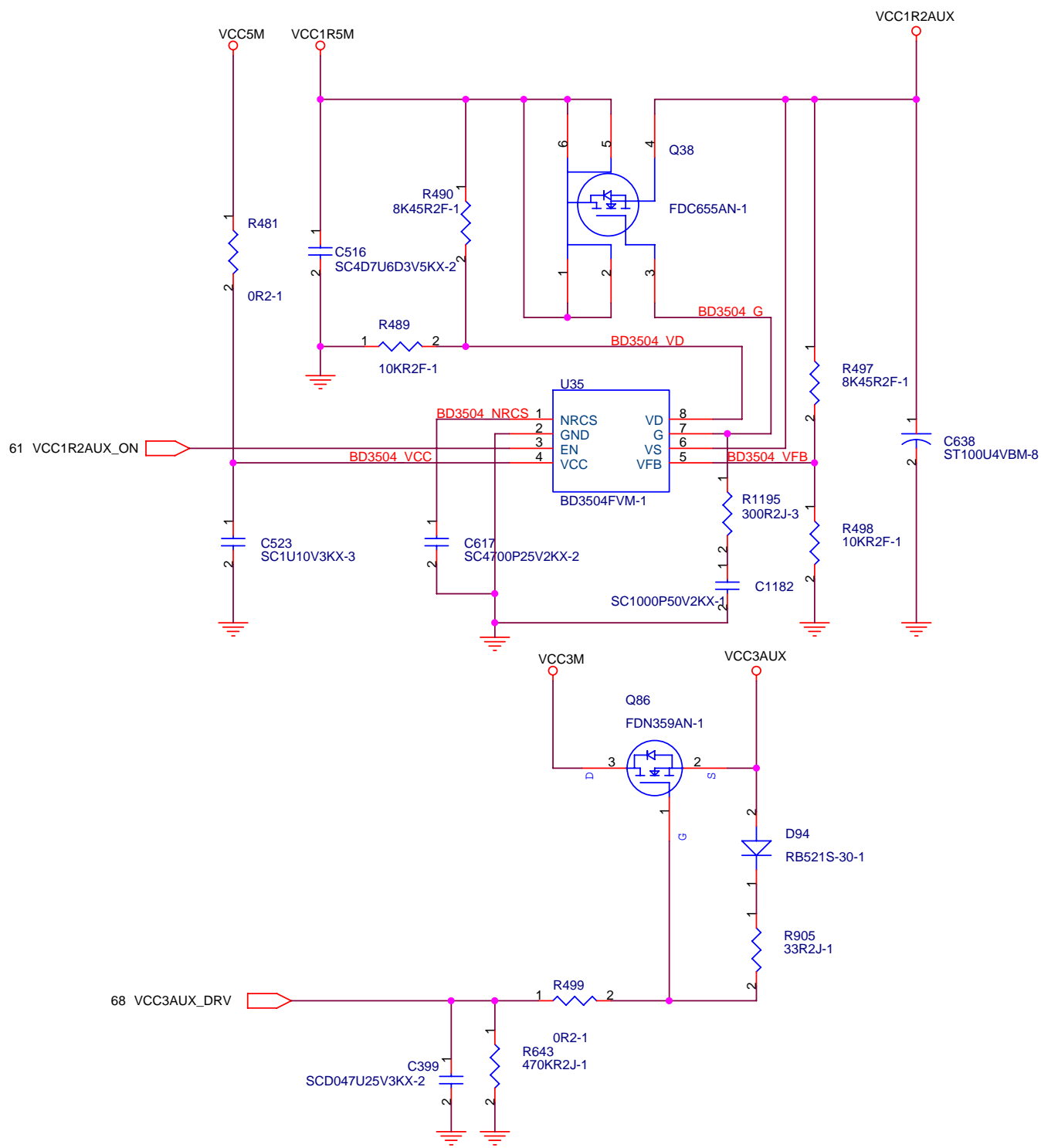
26P1710AA source package



 <b>Wistron Corporation</b> 21F, 88, Sec.1, Hsin Tai Wu Rd., Hsichih, Taipei Hsien 221, Taiwan, R.O.C.	
<b>LOAD SW 1(AUX)</b>	
Title	Document Number
Size A4	Rev -2
Date: Tuesday, December 28, 2004	
Sheet 69 of 71	

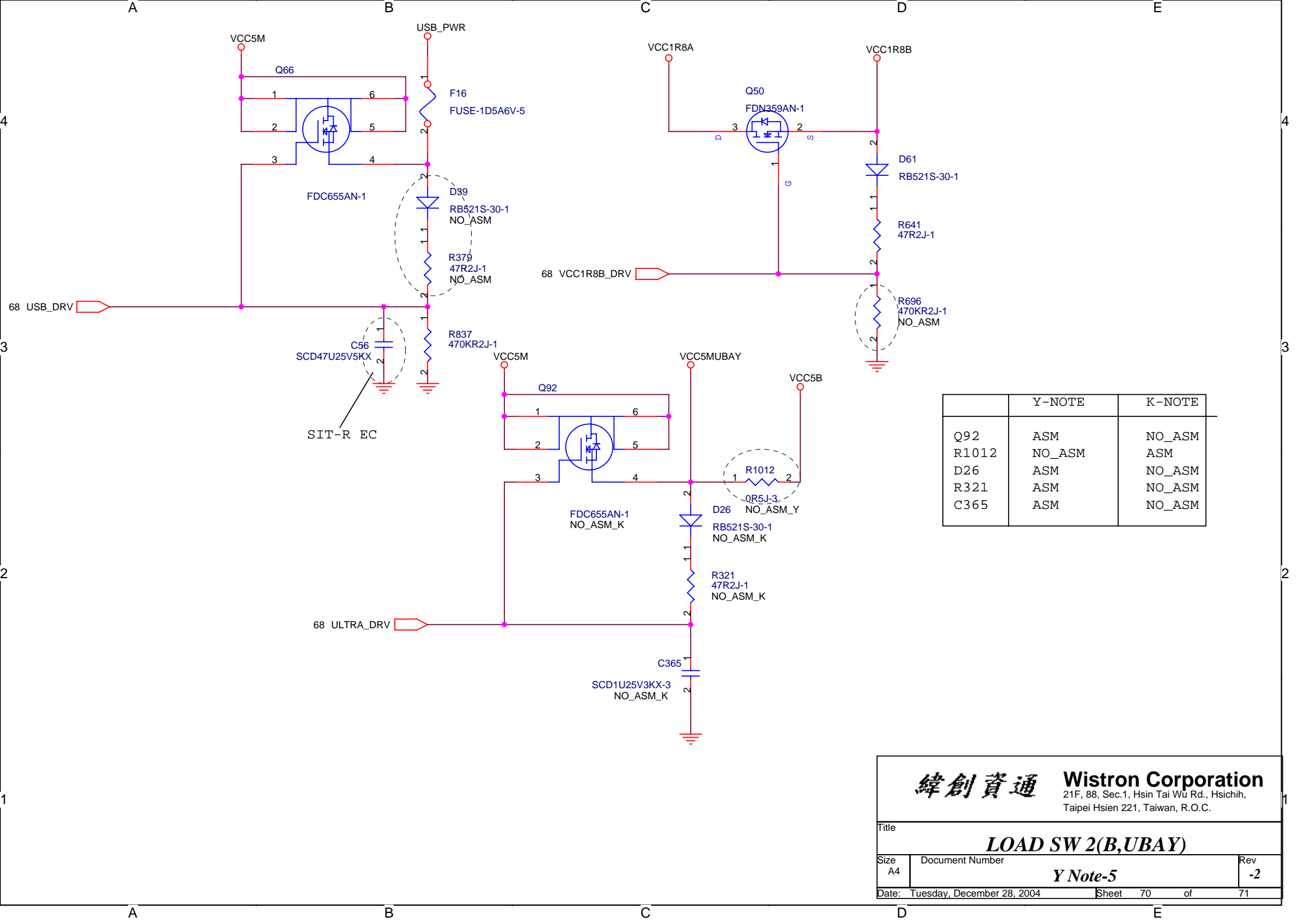

	Y-NOTE	K-NOTE
Q92	ASM	NO_ASM
R1012	NO_ASM	ASM
D26	ASM	NO_ASM
R321	ASM	NO_ASM
C365	ASM	NO_ASM

**Wistron Corporation**  
 21F, 88, Sec.1, Hsin Tai Wu Rd., Hsichih,  
 Taipei Hsien 221, Taiwan, R.O.C.

---

Title

**LOAD SW 2(B,UBAY)**

Size A4	Document Number <b>Y Note-5</b>	Rev -2
------------	------------------------------------	-----------

Date: Tuesday, December 28, 2004      Sheet 70 of 71

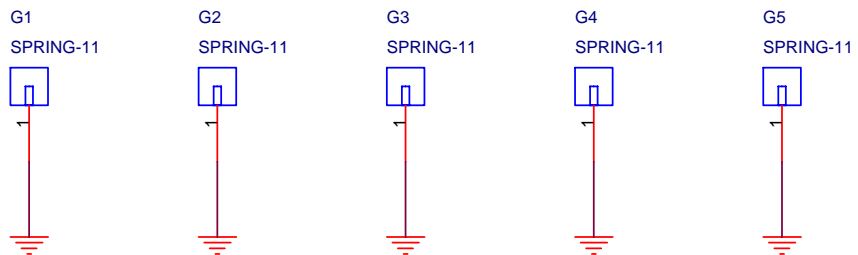
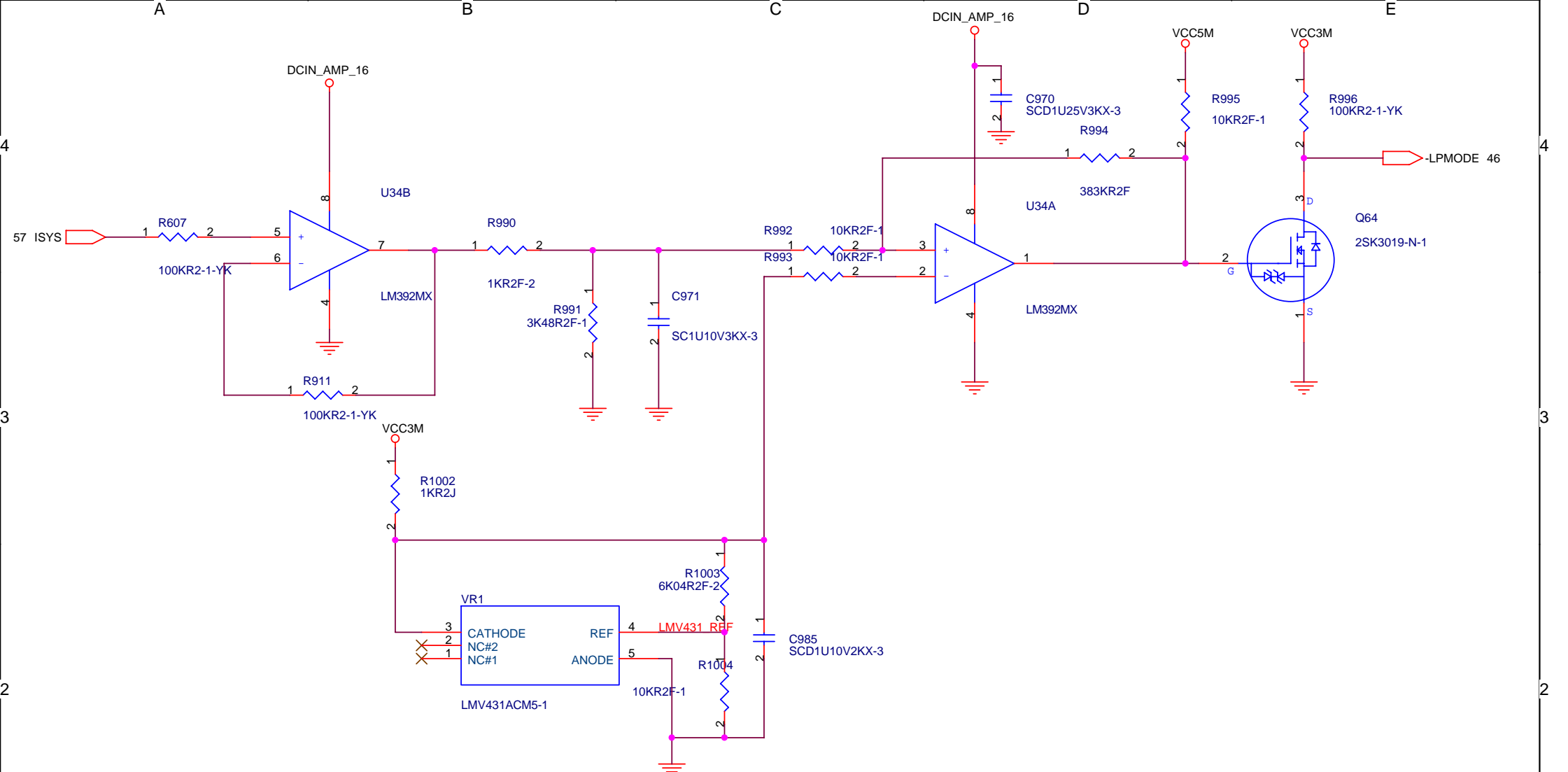

Vendor P/N: ATE-C-306

		<b>Wistron Corporation</b> 21F, 88, Sec.1, Hsin Tai Wu Rd., Hsichih, Taipei Hsien 221, Taiwan, R.O.C.	
Title			
<b>MAX POWER CTRL</b>			
Size A4	Document Number		Rev -2
Date: Tuesday, December 28, 2004		Sheet 71 of 71	